

**50 Hz**



# GZ10, GZ12 Series

10" - 12" SUBMERSIBLE  
ELECTRIC PUMPS

Cod. G91005601 Rev.C Ed.09/2012

 **GOULDS**  
WATER TECHNOLOGY  
a xylem brand

**GZ10, GZ12 SERIES  
 HYDRAULIC PERFORMANCE RANGE AT 50 Hz**

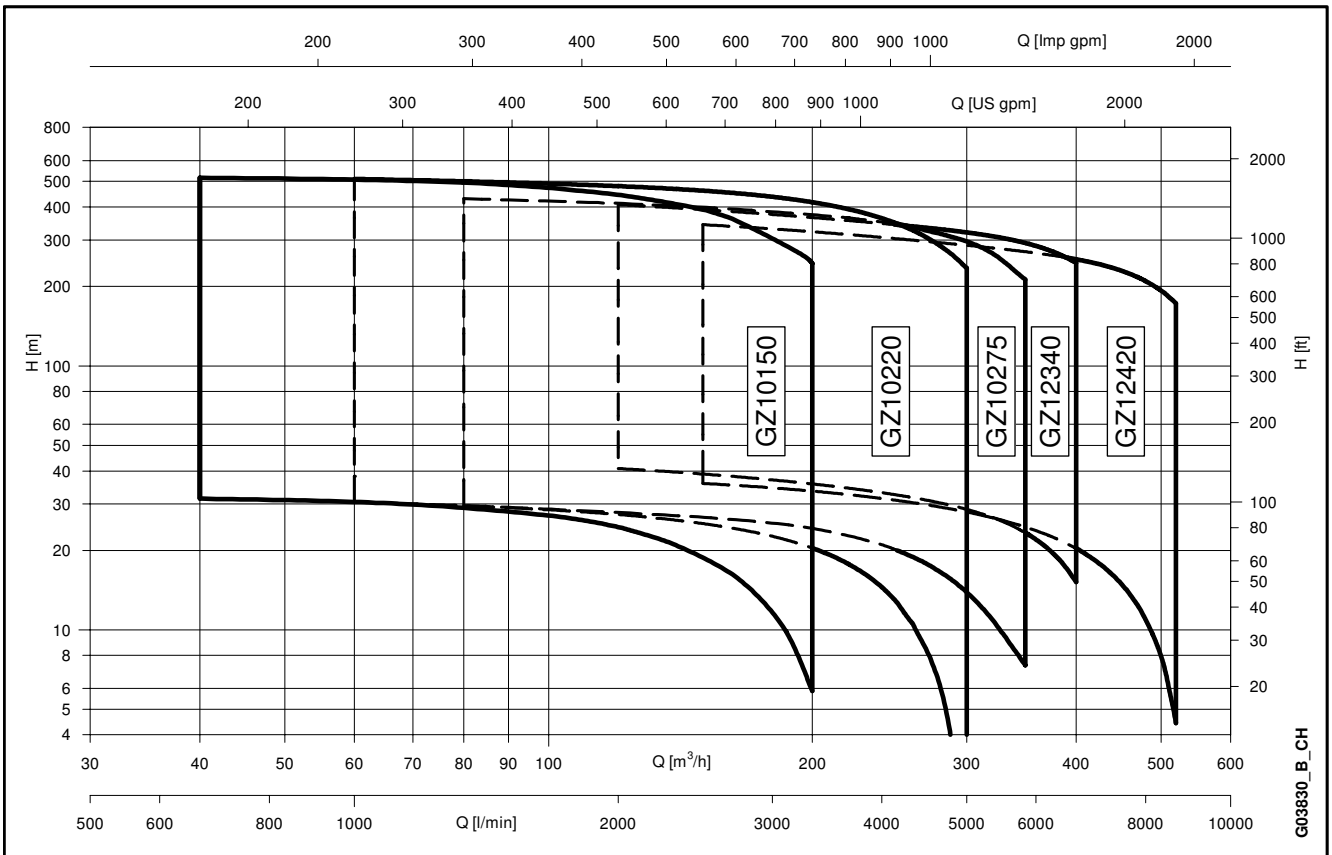

## **CONTENTS**

GZ10 Series Specifications .....	<b>5</b>
GZ10 Table of Materials .....	<b>6</b>
Hydraulic Performance Range, GZ10 Series 50 Hz .....	<b>7</b>
GZ12 Series Specifications .....	<b>31</b>
GZ12 Table of Materials .....	<b>32</b>
Hydraulic Performance Range, GZ12 Series 50 Hz .....	<b>33</b>
CP6W Series Motors .....	<b>49</b>
CP8W Series Motors .....	<b>57</b>
CP10W Series Motors .....	<b>65</b>
CP12W Series Motors .....	<b>71</b>
Accessories .....	<b>77</b>
Technical Appendix .....	<b>95</b>



## 10" Submersible Electric Pumps

### GZ10150 GZ10220 GZ10275 Series



### MARKET SECTORS

AGRICULTURAL, INDUSTRIAL, MUNICIPAL.

### APPLICATIONS

- Water supply from deep wells.
- Pressure boosting and water distribution in civil and industrial systems.
- Supply of surge tanks and reservoirs.
- Firefighting and washing systems.
- Water table level control.
- Irrigation.

### SPECIFICATIONS

#### PUMP

- **Delivery:** up to 350 m<sup>3</sup>/h.
- **Head:** up to 545 m.
- Maximum pump overall diameter (2 cable covers included): 271 mm.
- Maximum electric pump immersion depth: 350 m with CP6W, CP8W, CP10W and CP12W motors.
- The content of sand should not exceed 50 g/m<sup>3</sup>, higher contents up to 100 g/m<sup>3</sup> can be admitted, if wear is tolerated.
- Horizontal installation possible (it is recommended to have an incline of at least 3° with the motor on the lowest position).
- Standard delivery outlet: Rp 6" according to EN 10226.
- Motor power: from 11 to 300 kW.

#### MOTOR

- CP6W, CP8W, CP10W and CP12W rewindable water filled three-phase motors.
- **Three-phase version:**  
CP6W: 4 to 37 kW 380-415 V, 50 Hz.  
CP8W: 30 to 93 kW 380-415 V, 50 Hz.  
CP10W: 93 to 150 kW 380-415 V, 50 Hz.  
CP12W: 185 to 300 kW 380-415 V, 50 Hz.
- Maximum supply voltage variations: CP6W, CP8W, CP10W, CP12W 400V ± 10%.
- **Horizontal operation:**  
CP6W, all versions are designed for horizontal installation, provided that the direction of the axial thrust generated by the impellers is always from the pump to the motor.  
CP8W, CP10W, CP12W available on requests for all versions.

- Maximum number of starts per hour: 15 (CP6W), 10 (CP8W) 8 (CP10W) 4 (CP12W).
- Maximum temperature of water in contact with motor: CP6W, CP8W, CP10W and CP12W 30°C.
- **Special versions: AISI 316 and Duplex materials, HT** for applications in high temperature environments (up to 60°C) or under inverter.

### CONSTRUCTION

#### FEATURES

#### PUMP

- Robust but lightweight, easy to maintain and with high corrosion resistance.
- **Impeller** and **diffusers** made of stainless steel castings.
- Delivery head and suction support of stainless steel castings.
- Stainless steel non return valve integrated, spring equipped.
- Stainless steel shaft.
- Guide bearings and wear rings ensure high reliability and long lasting hydraulic performances.
- The new design ensures high efficiency and low power consumption
- **Special versions:** GZR10 made of **Duplex** stainless steel.
- Coupling according to **NEMA** standard for 6" and 8" motor, with key connection for 10" and 12" motor.

### ACCESSORIES

- Coupling flange.
- Panels.
- Drop cables.
- Cooling shrouds.
- Temperature sensor **PT 100 / PTC**.

## TABLE OF MATERIALS GZ10

COMPONENT	MATERIAL	DESIGNATION	
		EUROPE	USA
Delivery head / Valve Casing	Stainless steel	EN 10213-4-GX5CrNi19-10 (1.4308)	A744-CF 8
Valve	Stainless steel	EN 10213-4-GX5CrNi19-10 (1.4308)	A744-CF 8
Valve seat	NBR 90		
Valve spring	Stainless steel	EN 10088-1-X5CrNiMo17-12-2 (1.4401)	AISI 316
Diffuser / Bowl	Stainless steel	EN 10213-4-GX5CrNi19-10 (1.4308)	A744-CF 8
Diffuser O-Ring	NBR 70		
Impeller	Stainless steel	EN 10213-4-GX5CrNi19-10 (1.4308)	A744-CF 8
Taperlock	Duplex stainless steel	EN 10088-1-X2CrNiMoN22-5-3 (1.4462)	A276/A790-S31803
Wear ring	POM		
Lower support / Suction Casing	Stainless steel	EN 10213-4-GX5CrNi19-10 (1.4308)	A744-CF 8
Suction strainer	Stainless steel	DIN 17440-X6CrNiMoTi17-12-2 (1.4571)	AISI 316Ti
Pump shaft	Stainless steel	EN 10088-1-X17CrNi16-2 (1.4057)	AISI 431
Coupling	Duplex stainless steel	EN 10088-1-X2CrNiMoN22-5-3 (1.4462)	A276/A790-S31803
Bearing bush	EPDM + LOXAMID <sup>®</sup>		
Thrust Bearing	PTFE + 25% carbon		
Screw, stud, nut	Stainless steel	ISO 3506-1/2 A4-70	AISI 316
Cable protection	Stainless steel	EN 10088-1-X5CrNi18-10 (1.4301)	AISI 304

zr10-2p50-en\_b\_tm

## TABLE OF MATERIALS GZR10

COMPONENT	MATERIAL	DESIGNATION	
		EUROPE	USA
Delivery head / Valve Casing	Duplex stainless steel	EN 10213-4-GX2CrNiMoCuN25-6-3-3 (1.4517)	
Valve	Duplex stainless steel	EN 10213-4-GX2CrNiMoCuN25-6-3-3 (1.4517)	
Valve seat	NBR 90		
Valve spring	Hastelloy C4	DIN17744-NiMo16Cr16Ti (2.4610)	N06455
Diffuser / Bowl	Duplex stainless steel	EN 10213-4-GX2CrNiMoCuN25-6-3-3 (1.4517)	
Diffuser O-Ring	NBR 70		
Impeller	Duplex stainless steel	EN 10213-4-GX2CrNiMoCuN25-6-3-3 (1.4517)	
Taperlock	Duplex stainless steel	EN 10088-1-X2CrNiMoN22-5-3 (1.4462)	A276/A790-S31803
Wear ring	POM		
Lower support / Suction Casing	Duplex stainless steel	EN 10213-4-GX2CrNiMoCuN25-6-3-3 (1.4517)	
Suction strainer	Stainless steel	EN 10088-1X1NiCrMoCu25-20-5 (1.4539)	AISI 904L
Pump shaft	Duplex stainless steel	EN 10088-1-X2CrNiMoN22-5-3 (1.4462)	A276/A790-S31803
Coupling	Duplex stainless steel	EN 10088-1-X2CrNiMoN22-5-3 (1.4462)	A276/A790-S31803
Bearing bush	EPDM + LOXAMID <sup>®</sup>		
Thrust Bearing	PTFE + 25% carbon		
Screw, stud, nut	Duplex stainless steel	EN 10088-1-X2CrNiMoN22-5-3 (1.4462)	A276/A790-S31803
Cable protection	Stainless steel	EN 10088-1X1NiCrMoCu25-20-5 (1.4539)	AISI 904L

zr10-2p50-en\_a\_tm

## IDENTIFICATION CODE

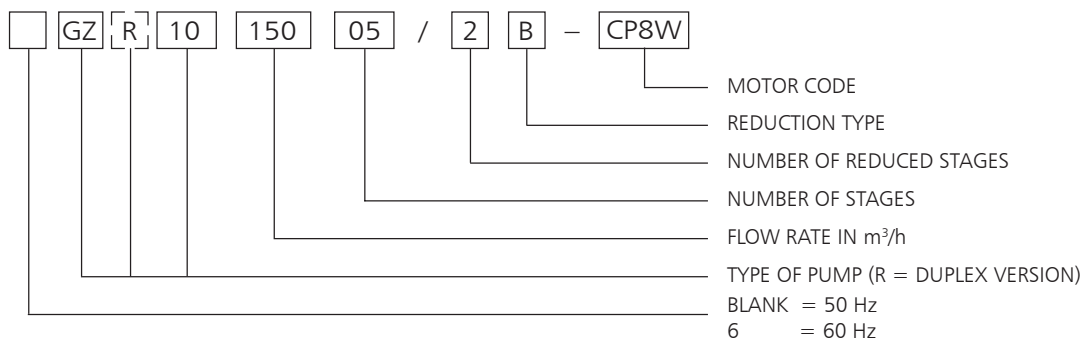

EXAMPLE : GZR10 150 05/2B - CP8W  
 10" electric pump, 50 Hz, made of DUPLEX, flow rate 150 m<sup>3</sup>/h, 5 stages including 2 reduced ones, coupled to an 8" CP8W motor.

**GZ10 SERIES  
HYDRAULIC PERFORMANCE RANGE AT 50 Hz**

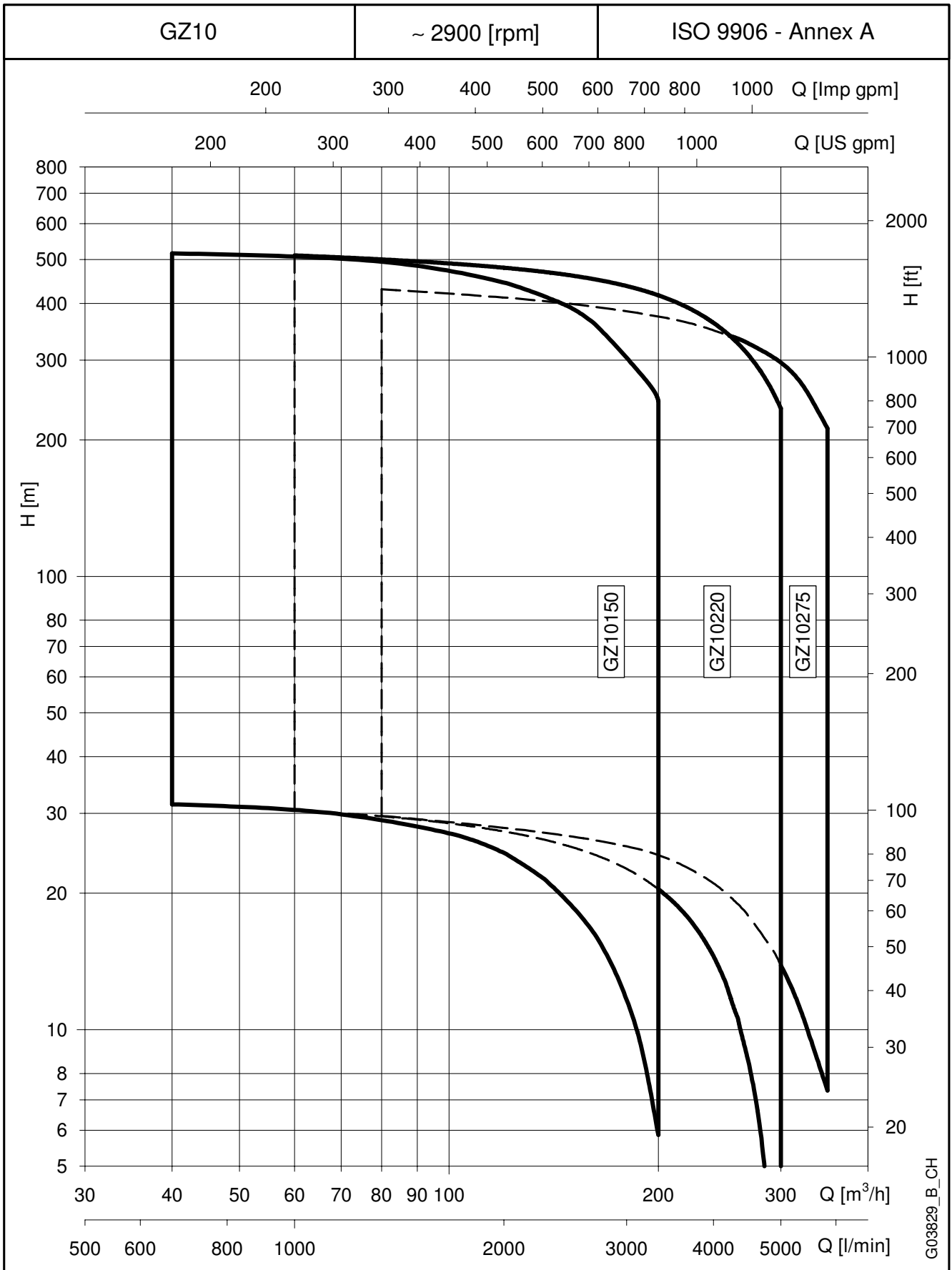

## GZ10150 SERIES, 1 TO 3 STAGES OPERATING CHARACTERISTICS AT 50 Hz

PUMP TYPE	RATED POWER	Q = DELIVERY						
		l/min	0	667	1333	2000	2500	3000
		m <sup>3</sup> /h	0	40	80	120	150	180
kW		H = TOTAL HEAD METRES COLUMN OF WATER						
GZ10150 01/1C	11	34	31	29	25	19	12	
GZ10150 01/1B	13	39	36	34	30	25	18	
GZ10150 01/1A	15	42	40	38	34	29	22	
GZ10150 02/2C	22	67	63	58	49	38	23	
GZ10150 02/2B	26	79	74	70	60	50	36	
GZ10150 02/2A	30	86	81	77	68	59	45	
GZ10150 03/2C	37	112	105	98	85	69	48	
GZ10150 03/2B	45	123	116	109	96	81	61	
GZ10150 03/2A	45	129	121	115	102	88	68	
GZ10150 03	52	134	126	121	109	94	74	

gz10150-2p50-1-en\_a\_th

## DIMENSIONS AND WEIGHTS

PUMP TYPE	RATED POWER	DIMENSIONS (mm)				WEIGHT
		A (4)	C (1)	M	T (2)	
	kW					kg (3)
GZ10150 01/1C-CP6W	11	1428	258	144	2323	103
GZ10150 01/1B-CP6W	13	1468	258	144	2363	107
GZ10150 01/1A-CP6W	15	1538	258	144	2433	115
GZ10150 02/2C-CP6W	22	1864	258	144	2543	146
GZ10150 02/2B-CP6W	26	1992	258	144	2671	155
GZ10150 02/2A-CP6W	30	2072	258	144	2751	163
GZ10150 03/2C-CP6W	37	2388	258	144	2851	203
GZ10150 03/2B-CP8W	45	2332	258	192	2795	270
GZ10150 03/2A-CP8W	45	2332	258	192	2795	270
GZ10150 03-CP8W	52	2422	258	192	2885	290

gz10150-2p50-1-en\_a\_td

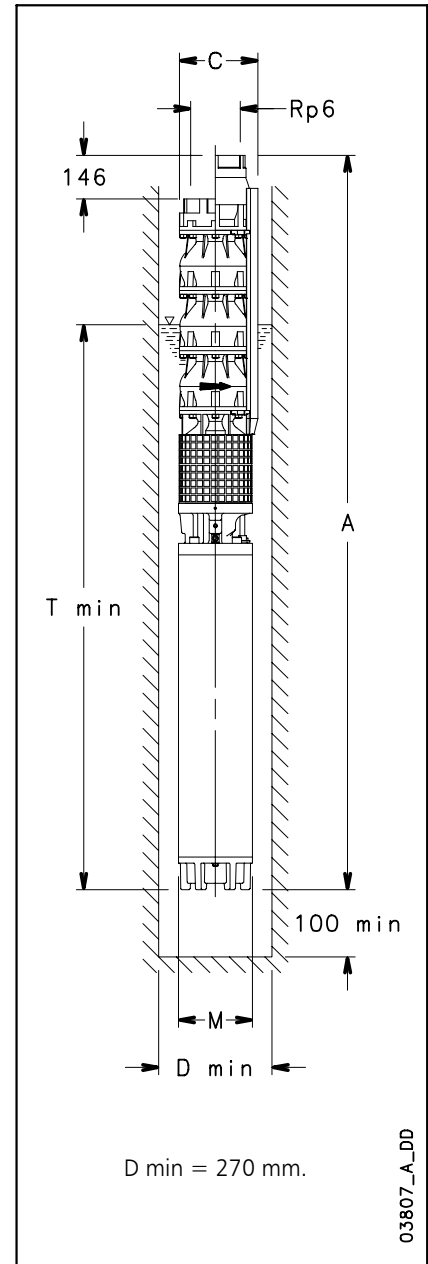

- 1) Max electric pump diameter with 2 motor cables included.  
In case of 1 motor cable C = 255 mm with CP6W motor.  
C = 255 mm with CP8W motor.
- 2) T min valid only for max flow speed of 4,5 m/s between pump and perforation pipe.  
In case this velocity is exceeded, please contact our sales network.
- 3) Without cables.
- 4) For pumps without non-return valve, reduce dimension A by 146 mm, and reduce weight by 8,3 Kg.



**GZ10150 SERIES, 1 TO 3 STAGES  
OPERATING CHARACTERISTICS AT 50 Hz**

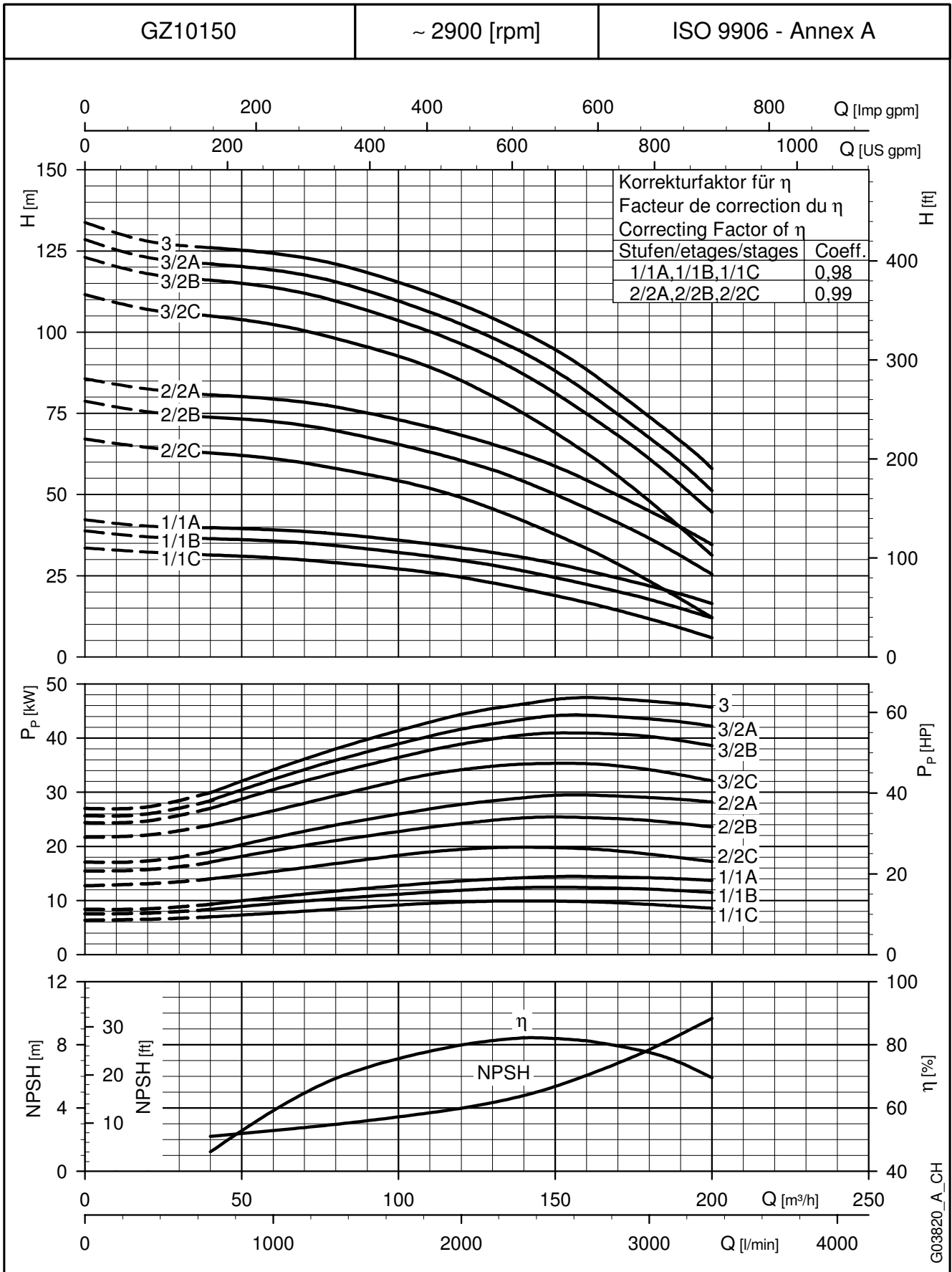

These performances are valid for liquids with density  $\rho = 1.0 \text{ Kg/dm}^3$  and kinematic viscosity  $\nu = 1 \text{ mm}^2/\text{sec}$ .

**GZ10150 SERIES, 4 TO 6 STAGES  
OPERATING CHARACTERISTICS AT 50 Hz**

PUMP TYPE	RATED POWER	Q = DELIVERY						
		l/min	0	667	1333	2000	2500	3000
		m <sup>3</sup> /h	0	40	80	120	150	180
kW		H = TOTAL HEAD METRES COLUMN OF WATER						
GZ10150 04/2C	52	157	147	138	122	101	74	
GZ10150 04/2B	60	169	158	150	133	113	87	
GZ10150 04	67	178	168	161	145	126	98	
GZ10150 05/2C	67	201	189	178	158	132	98	
GZ10150 05/2B	75	212	199	189	168	144	110	
GZ10150 05	83	221	209	200	179	156	122	
GZ10150 06/2C	83	245	231	218	194	163	122	
GZ10150 06/1B	93	263	248	236	211	183	143	
GZ10150 06	110	273	158	247	223	194	154	

gz10150-2p50-2-en\_a\_th

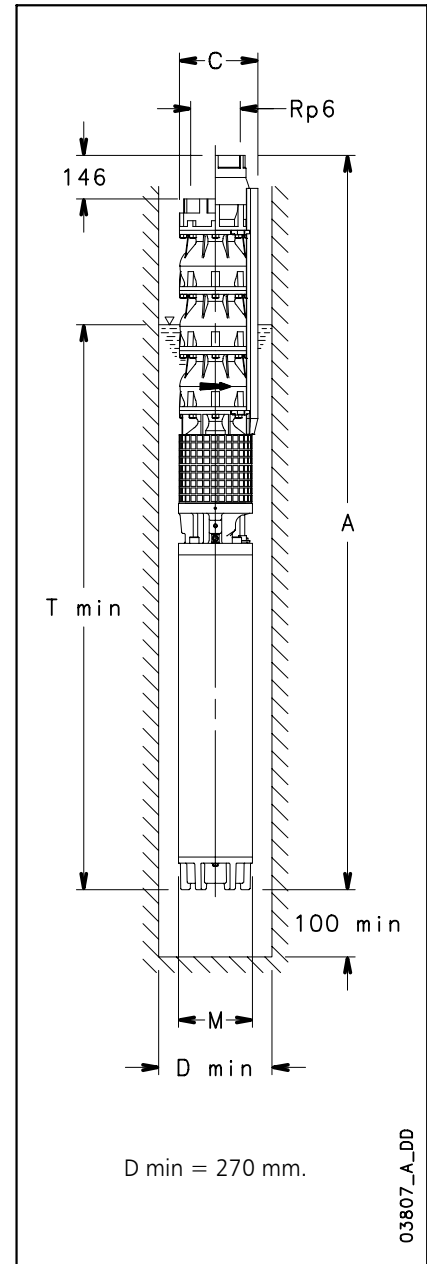

**DIMENSIONS AND WEIGHTS**

PUMP TYPE	RATED POWER	DIMENSIONS (mm)				WEIGHT
		A (4)	C (1)	M	T (2)	
	kW					kg (3)
GZ10150 04/2C-CP8W	52	2638	258	192	2885	311
GZ10150 04/2B-CP8W	60	2728	258	192	2975	328
GZ10150 04-CP8W	67	2818	258	192	3065	346
GZ10150 05/2C-CP8W	67	3034	258	192	3065	367
GZ10150 05/2B-CP8W	75	3124	258	192	3155	384
GZ10150 05-CP8W	83	3184	258	192	3215	397
GZ10150 06/2C-CP8W	83	3400	258	192	3215	417
GZ10150 06/1B-CP8W	93	3540	258	192	3355	442
GZ10150 06-CP10W	110	3524	259	236	3302	558

gz10150-2p50-2-en\_a\_td

- 1) Max electric pump diameter with 2 motor cables included.  
In case of 1 motor cable C = 255 mm with CP8W motor.  
C = 255 mm with CP10W motor.
- 2) T min valid only for max flow speed of 4,5 m/s between pump and perforation pipe.  
In case this velocity is exceeded, please contact our sales network.
- 3) Without cables.
- 4) For pumps without non-return valve, reduce dimension A by 146 mm, and reduce weight by 8,3 Kg.

**GZ10150 SERIES, 4 TO 6 STAGES  
 OPERATING CHARACTERISTICS AT 50 Hz**

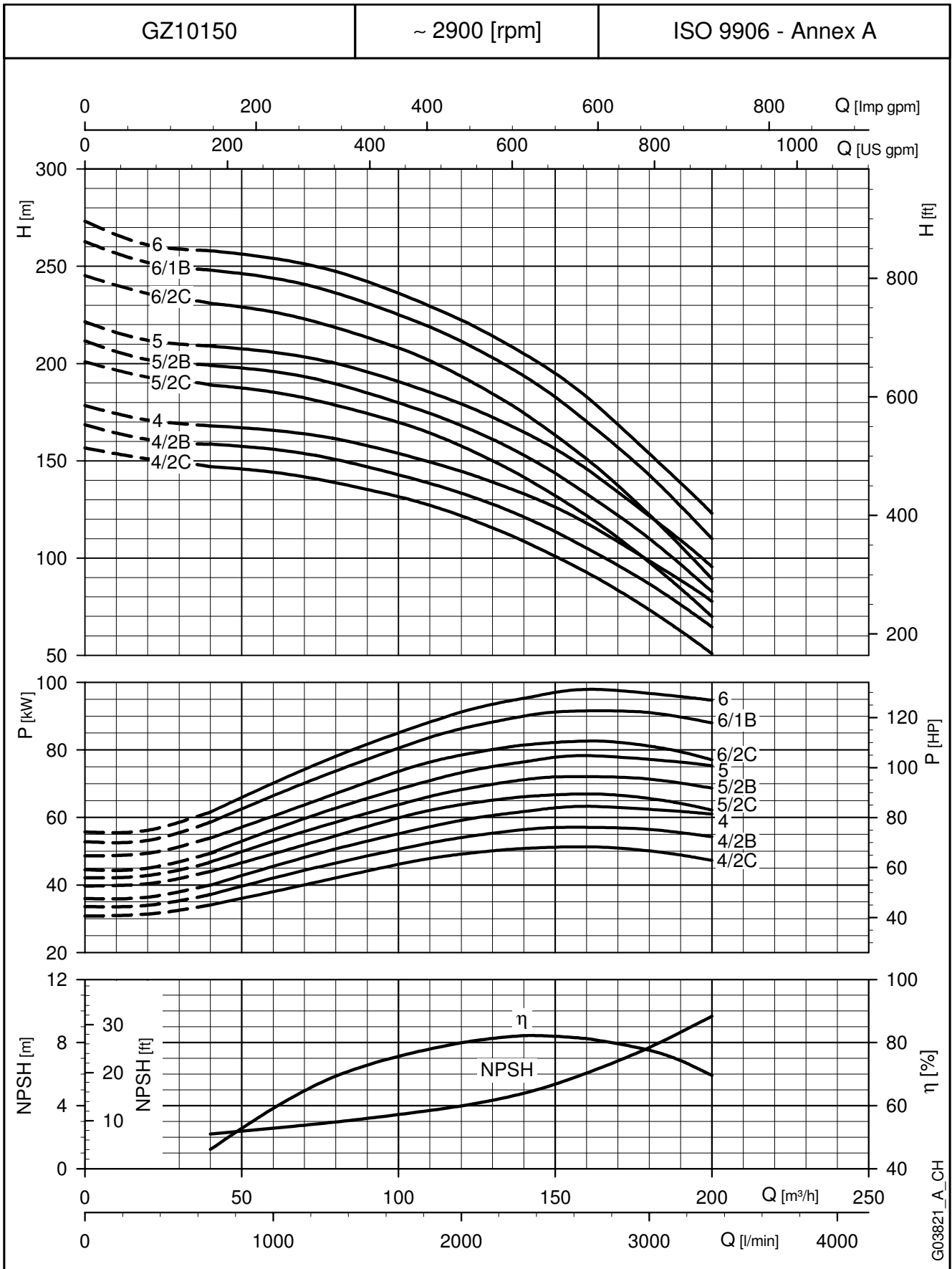

These performances are valid for liquids with density  $\rho = 1.0 \text{ Kg/dm}^3$  and kinematic viscosity  $\nu = 1 \text{ mm}^2/\text{sec}$ .

## GZ10150 SERIES, 7 TO 12 STAGES OPERATING CHARACTERISTICS AT 50 Hz

PUMP TYPE	RATED POWER	Q = DELIVERY						
		l/min	0	667	1333	2000	2500	3000
		m <sup>3</sup> /h	0	40	80	120	150	180
kW		H = TOTAL HEAD METRES COLUMN OF WATER						
GZ10150 07/3B	110	301	284	270	240	207	159	
GZ10150 07/1B	110	312	294	280	252	219	172	
GZ10150 08/3B	130	349	329	313	279	241	189	
GZ10150 08	130	362	342	327	295	257	203	
GZ10150 09/3B	150	395	372	354	316	274	213	
GZ10150 09	150	410	387	371	335	292	231	
GZ10150 10	185	455	430	412	372	324	257	
GZ10150 11	185	499	472	452	407	355	281	
GZ10150 12	220	546	517	494	446	389	308	

gz10150-2p50-3-en\_a\_th

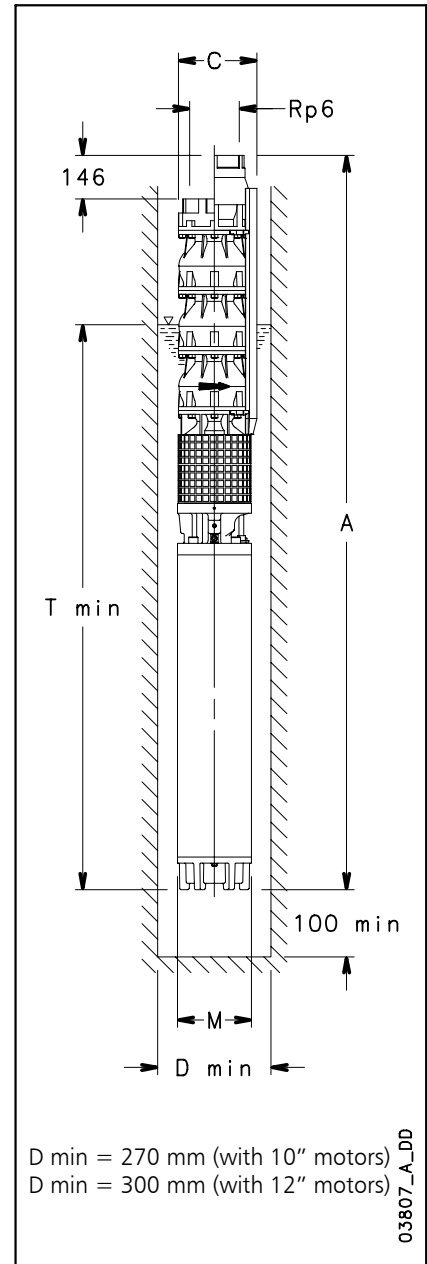

## DIMENSIONS AND WEIGHTS

PUMP TYPE	RATED POWER	DIMENSIONS (mm)				WEIGHT
		A (4)	C (1)	M	T (2)	
GZ10150 07/3B-CP10W	110	3740	259	236	3302	579
GZ10150 07/1B-CP10W	110	3740	259	236	3302	579
GZ10150 08/3B-CP10W	130	4106	259	236	3452	647
GZ10150 08-CP10W	130	4106	259	236	3452	647
GZ10150 09/3B-CP10W	150	4452	259	236	3582	706
GZ10150 09-CP10W	150	4452	259	236	3582	706
GZ10150 10-CP12W	185	4425	283	276	3339	793
GZ10150 11-CP12W	185	4641	283	276	3339	814
GZ10150 12-CP12W	220	5007	283	276	3489	898

gz10150-2p50-3-en\_a\_td

- 1) Max electric pump diameter with 2 motor cables included.  
In case of 1 motor cable C = 255 mm with CP10W motor.  
C = 280 mm with CP12W motor.
- 2) T min valid only for max flow speed of 4,5 m/s between pump and perforation pipe.  
In case this velocity is exceeded, please contact our sales network.
- 3) Without cables.
- 4) For pumps without non-return valve, reduce dimension A by 146 mm, and reduce weight by 8,3 Kg.

**GZ10150 SERIES, 7 TO 12 STAGES  
 OPERATING CHARACTERISTICS AT 50 Hz**

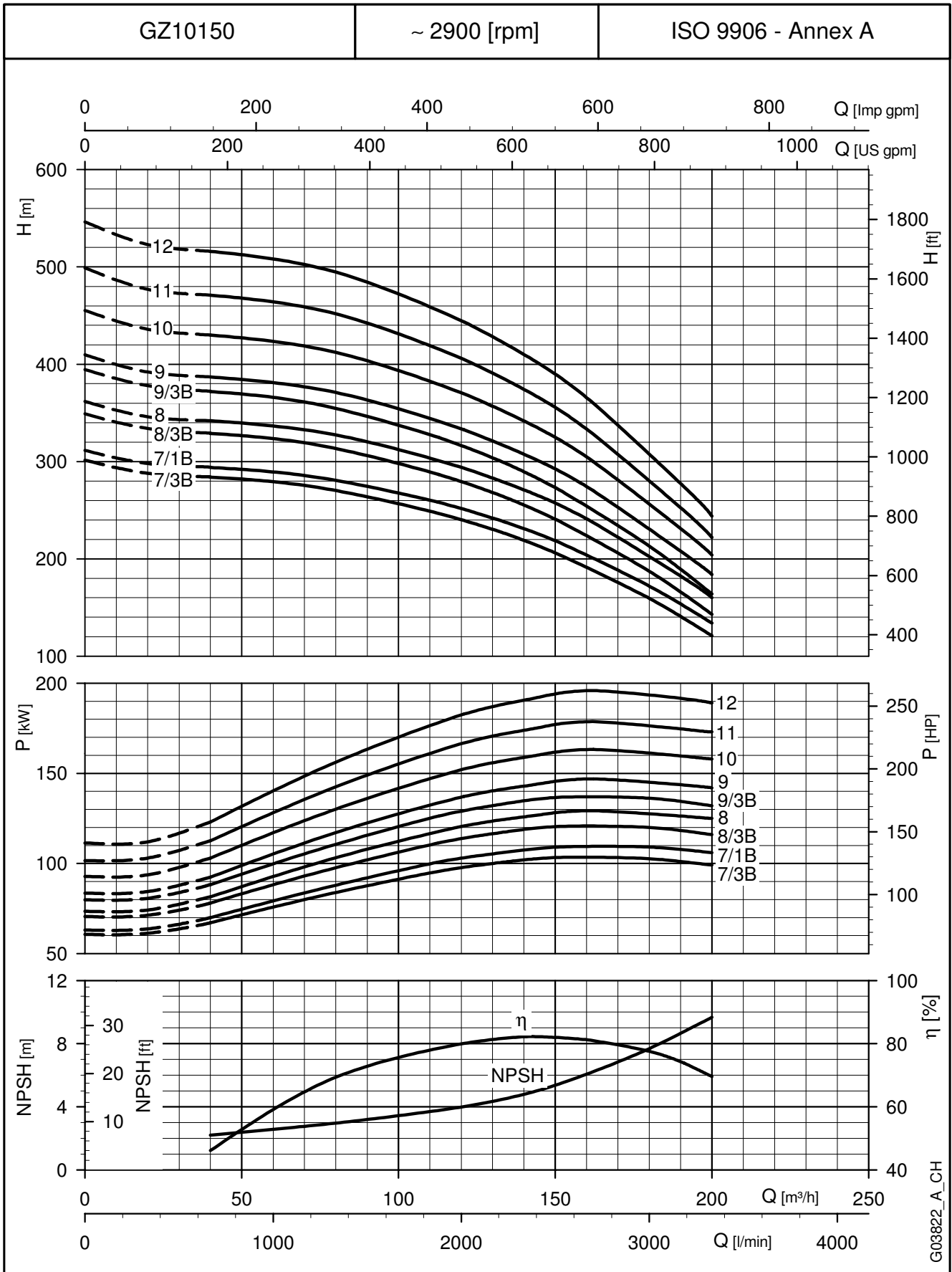

These performances are valid for liquids with density  $\rho = 1.0 \text{ Kg/dm}^3$  and kinematic viscosity  $\nu = 1 \text{ mm}^2/\text{sec}$ .

## GZ10220 SERIES, 1 TO 3 STAGES OPERATING CHARACTERISTICS AT 50 Hz

PUMP TYPE	RATED POWER	Q = DELIVERY						
		l/min	0	1000	2000	300	400	500
		m <sup>3</sup> /h	0	60	120	180	240	300
kW		H = TOTAL HEAD METRES COLUMN OF WATER						
GZ10220 01/1C	15	32,5	30,4	27,2	22,3	14,5	1,0	
GZ10220 01/1B	18,5	37,2	34,9	32,1	27,9	20,3	8,3	
GZ10220 01/1A	22	41,3	38,7	35,9	32,4	25,0	13,6	
GZ10220 01	26	44,7	41,6	38,8	35,6	28,7	18,3	
GZ10220 02/2C	30	65,5	61,2	54,9	45,8	29,5	2,0	
GZ10220 02/2B	37	75,4	70,8	65,1	56,9	41,7	16,8	
GZ10220 02/2A	45	83,9	78,4	72,9	65,8	51,1	28,6	
GZ10220 02	52	89,4	83,2	77,6	71,2	57,5	36,8	
GZ10220 03/2B	60	119,9	112,3	103,8	92,2	70,5	35,3	
GZ10220 03/2A	67	128,5	120,1	111,6	101,2	79,8	46,8	
GZ10220 03	75	134,1	124,8	116,3	106,7	86,3	55,1	

gz10220-2p50-1-en\_a\_th

## DIMENSIONS AND WEIGHTS

PUMP TYPE	RATED POWER	DIMENSIONS (mm)				WEIGHT
		A (4)	C (1)	M	T (2)	
	kW					kg (3)
GZ10220 01/1C-CP6W	15	1538	258	144	3733	114
GZ10220 01/1B-CP6W	18,5	1608	258	144	3803	122
GZ10220 01/1A-CP6W	22	1648	258	144	3843	125
GZ10220 01-CP6W	26	1776	258	144	3971	134
GZ10220 02/2C-CP6W	30	2072	258	144	4051	161
GZ10220 02/2B-CP6W	37	2172	258	144	4151	180
GZ10220 02/2A-CP8W	45	2116	258	192	4095	247
GZ10220 02-CP8W	52	2206	258	192	4185	267
GZ10220 03/2B-CP8W	60	2512	258	192	4275	304
GZ10220 03/2A-CP8W	67	2602	258	192	4365	322
GZ10220 03-CP8W	75	2692	258	192	4455	339

gz10220-2p50-1-en\_a\_td

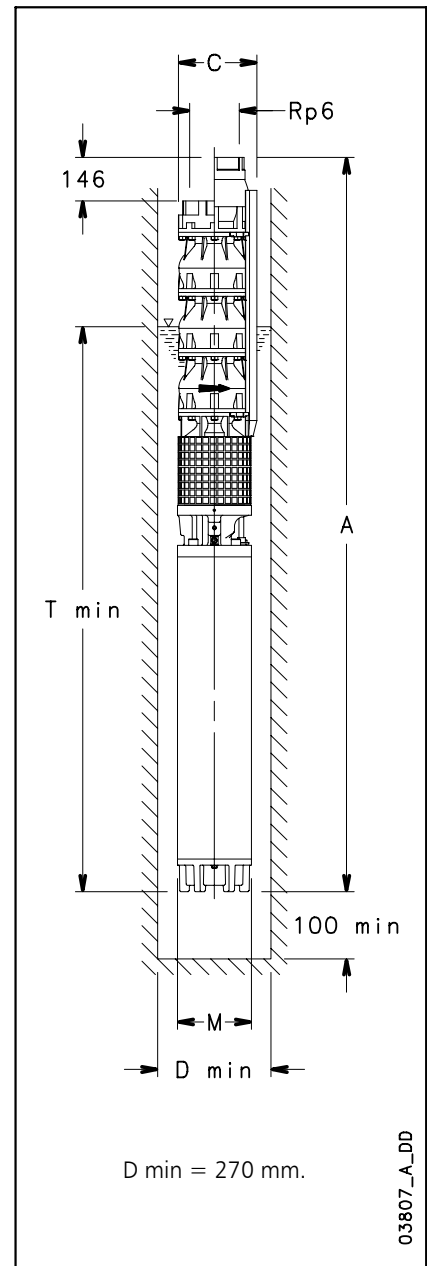

- 1) Max electric pump diameter with 2 motor cables included.  
In case of 1 motor cable C = 255 mm with CP6W motor.  
C = 255 mm with CP8W motor.
- 2) T min valid only for max flow speed of 4,5 m/s between pump and perforation pipe.  
In case this velocity is exceeded, please contact our sales network.
- 3) Without cables.
- 4) For pumps without non-return valve, reduce dimension A by 146 mm, and reduce weight by 8,3 Kg.

**GZ10220 SERIES, 1 TO 3 STAGES  
OPERATING CHARACTERISTICS AT 50 Hz**

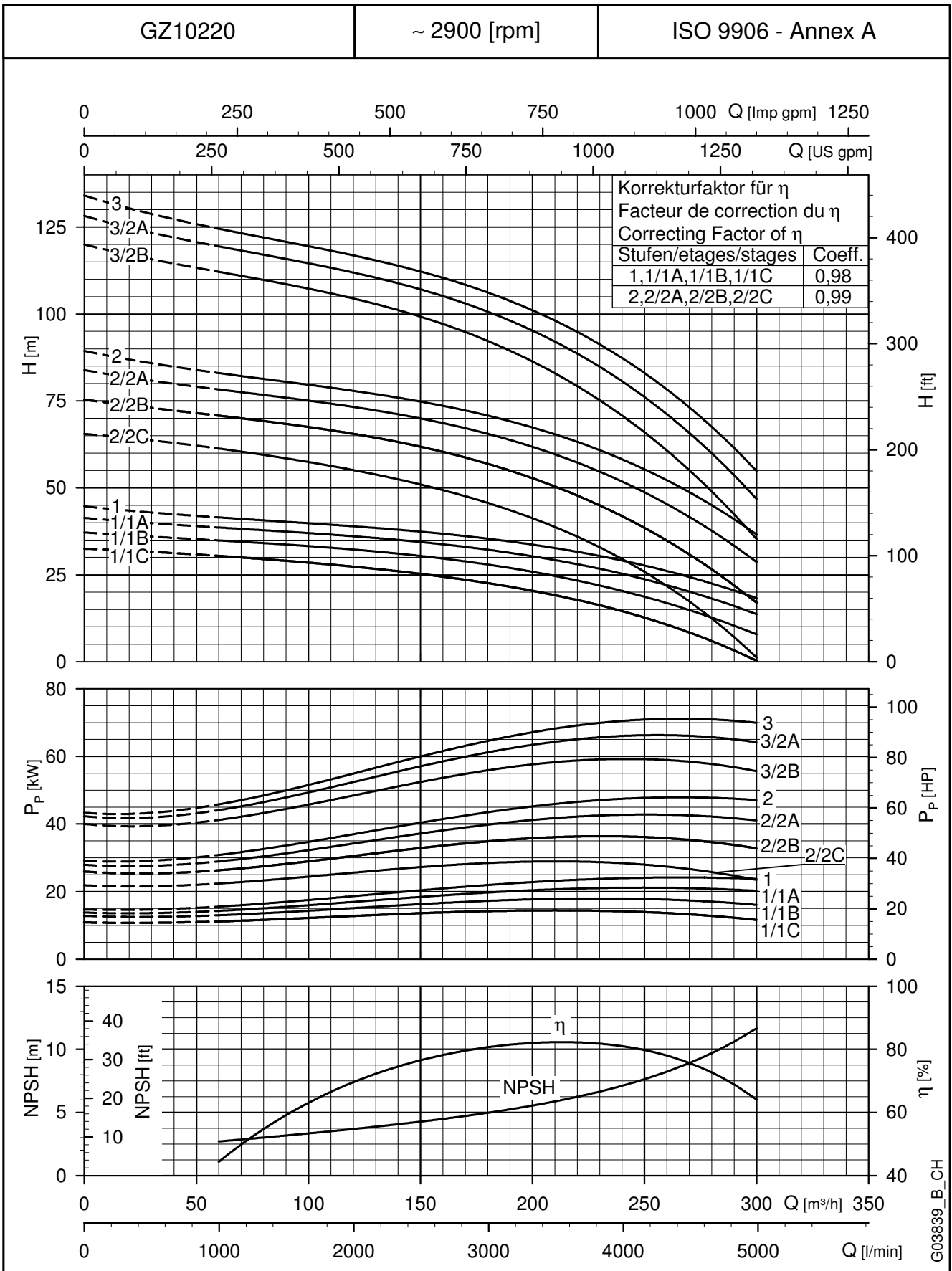

These performances are valid for liquids with density  $\rho = 1.0 \text{ Kg/dm}^3$  and kinematic viscosity  $\nu = 1 \text{ mm}^2/\text{sec}$ .

**GZ10220 SERIES, 4 TO 7 STAGES  
OPERATING CHARACTERISTICS AT 50 Hz**

PUMP TYPE	RATED POWER	Q = DELIVERY						
		l/min	0	1000	2000	3000	4000	5000
		m <sup>3</sup> /h	0	60	120	180	240	300
kW		H = TOTAL HEAD METRES COLUMN OF WATER						
GZ10220 04/2B	83	165	155	143	128	99	54	
GZ10220 04/2A	93	173	162	150	137	109	66	
GZ10220 04	110	182	170	159	146	119	79	
GZ10220 05/2B	110	215	201	186	168	133	79	
GZ10220 05	130	231	213	199	182	148	99	
GZ10220 06/2B	150	262	245	228	206	165	100	
GZ10220 06	150	274	255	238	219	178	118	
GZ10220 07/2B	185	305	297	278	256	208	118	
GZ10220 07	185	320	297	278	256	208	138	

gz10220-2p50-2-en\_a\_th

**DIMENSIONS AND WEIGHTS**

PUMP TYPE	RATED POWER	DIMENSIONS (mm)				WEIGHT
		A (4)	C (1)	M	T (2)	
	kW					kg (3)
GZ10220 04/2B-CP8W	83	2968	258	192	4515	371
GZ10220 04/2A-CP8W	93	3108	258	192	4655	396
GZ10220 04-CP10W	110	3092	259	236	4602	512
GZ10220 05/2B-CP10W	110	3308	259	236	4602	531
GZ10220 05-CP10W	130	3458	259	236	4752	578
GZ10220 06/2B-CP10W	150	3804	259	236	4882	636
GZ10220 06-CP10W	150	3804	259	236	4882	636
GZ10220 07/2B-CP12W	185	3777	283	276	4639	722
GZ10220 07-CP12W	185	3777	283	276	4639	722

gz10200-2p50-2-en\_a\_td

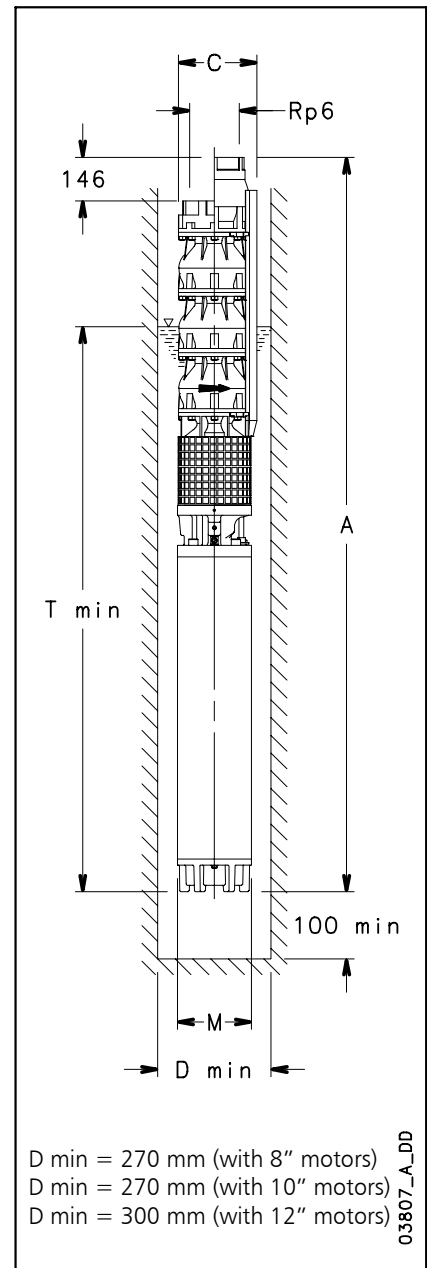

- 1) Max electric pump diameter with 2 motor cables included.  
In case of 1 motor cable C = 255 mm with CP8W motor.  
C = 255 mm with CP10W motor and C = 280 mm with CP12W motor.
- 2) T min valid only for max flow speed of 4,5 m/s between pump and perforation pipe.  
In case this velocity is exceeded, please contact our sales network.
- 3) Without cables.
- 4) For pumps without non-return valve, reduce dimension A by 146 mm, and reduce weight by 8,3 Kg.



**GZ10220 SERIES, 4 TO 7 STAGES  
OPERATING CHARACTERISTICS AT 50 Hz**

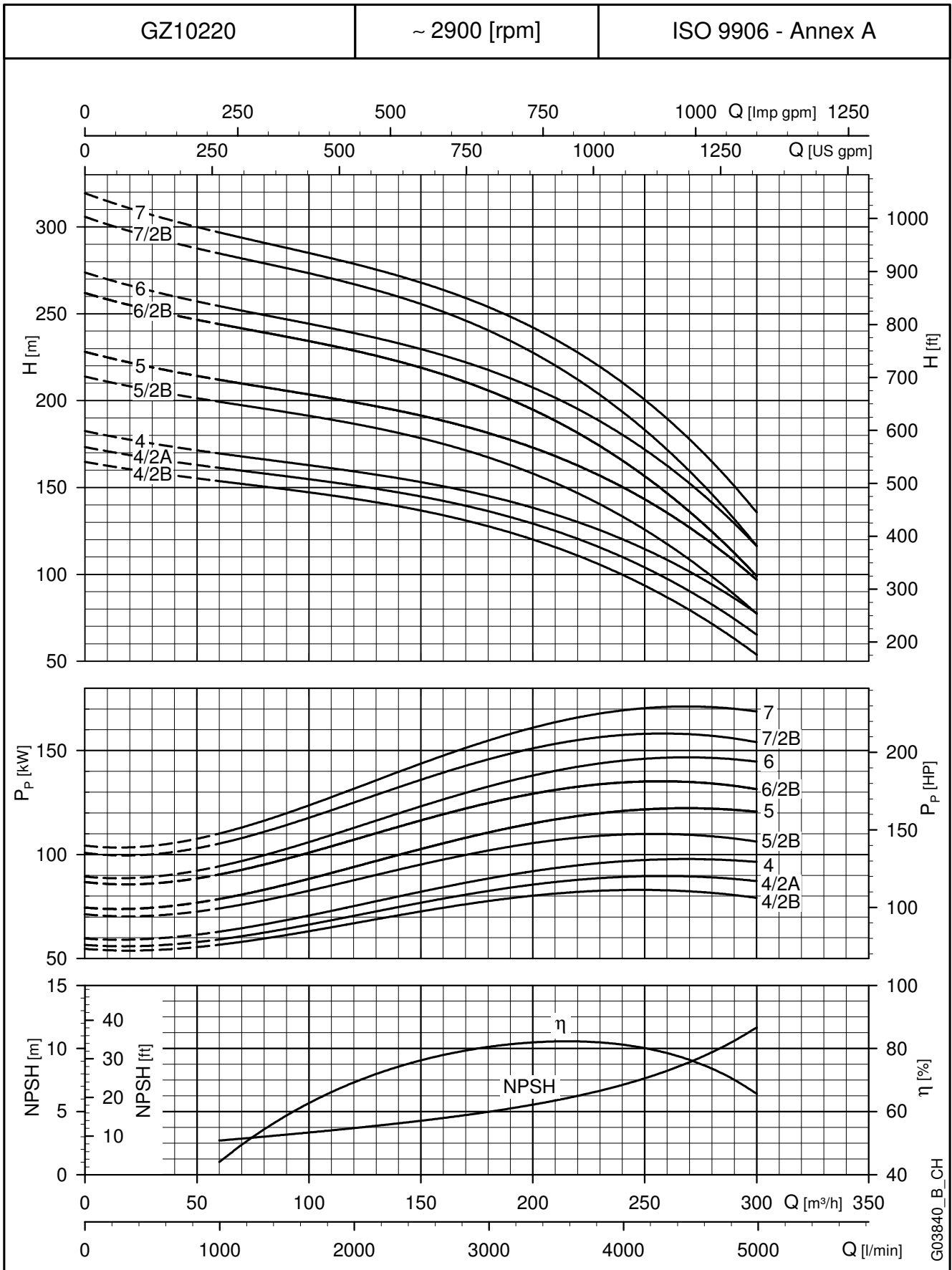

These performances are valid for liquids with density  $\rho = 1.0 \text{ Kg/dm}^3$  and kinematic viscosity  $\nu = 1 \text{ mm}^2/\text{sec}$ .

**GZ10220 SERIES, 8 TO 12 STAGES**  
**OPERATING CHARACTERISTICS AT 50 Hz**

PUMP TYPE	RATED POWER	Q = DELIVERY						
		l/min	0	1000	2000	3000	4000	5000
		m <sup>3</sup> /h	0	60	120	180	240	300
kW		H = TOTAL HEAD METRES COLUMN OF WATER						
GZ10220 08/2B	185	351	328	305	277	223	138	
GZ10220 08	220	367	343	321	294	241	160	
GZ10220 09/2B	220	399	373	347	316	255	160	
GZ10220 09/1A	220	410	383	357	328	267	173	
GZ10220 10/2B	260	446	416	387	353	285	179	
GZ10220 10	260	460	428	400	368	300	200	
GZ10220 11/2B	260	488	456	423	386	312	196	
GZ10220 11	300	505	471	440	405	330	220	
GZ10220 12/2B	300	536	500	465	425	344	218	
GZ10220 12	300	549	512	478	440	358	235	

gz10220-2p50-3-en\_a\_th

**DIMENSIONS AND WEIGHTS**

PUMP TYPE	RATED POWER	DIMENSIONS (mm)				WEIGHT
		A (4)	C (1)	M	T (2)	
GZ10220 08/2B-CP12W	185	3993	283	276	4639	741
GZ10220 08-CP12W	220	4143	283	276	4789	805
GZ10220 09/2B-CP12W	220	4359	283	276	4789	824
GZ10220 09/1A-CP12W	220	4359	283	276	4789	824
GZ10220 10/2B-CP12W	260	4725	283	276	4939	907
GZ10220 10-CP12W	260	4725	283	276	4939	907
GZ10220 11/2B-CP12W	260	4941	283	276	4939	927
GZ10220 11-CP12W	300	5091	283	276	5089	992
GZ10220 12/2B-CP12W	300	5307	283	276	5089	1011
GZ10220 12-CP12W	300	5307	283	276	5089	1011

gz10220-2p50-3-en\_a\_td

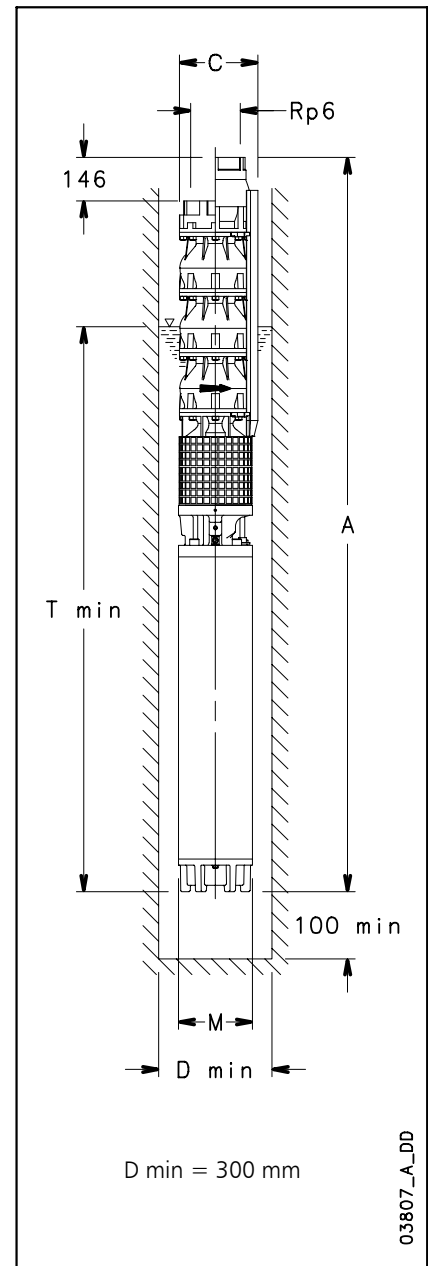

- 1) Max electric pump diameter with 2 motor cables included.  
 In case of 1 motor cable C = 280 mm with CP12W motor.
- 2) T min valid only for max flow speed of 4,5 m/s between pump and perforation pipe.  
 In case this velocity is exceeded, please contact our sales network.
- 3) Without cables.
- 4) For pumps without non-return valve, reduce dimension A by 146 mm, and reduce weight by 8,3 Kg.

**GZ10220 SERIES, 8 TO 12 STAGES  
 OPERATING CHARACTERISTICS AT 50 Hz**

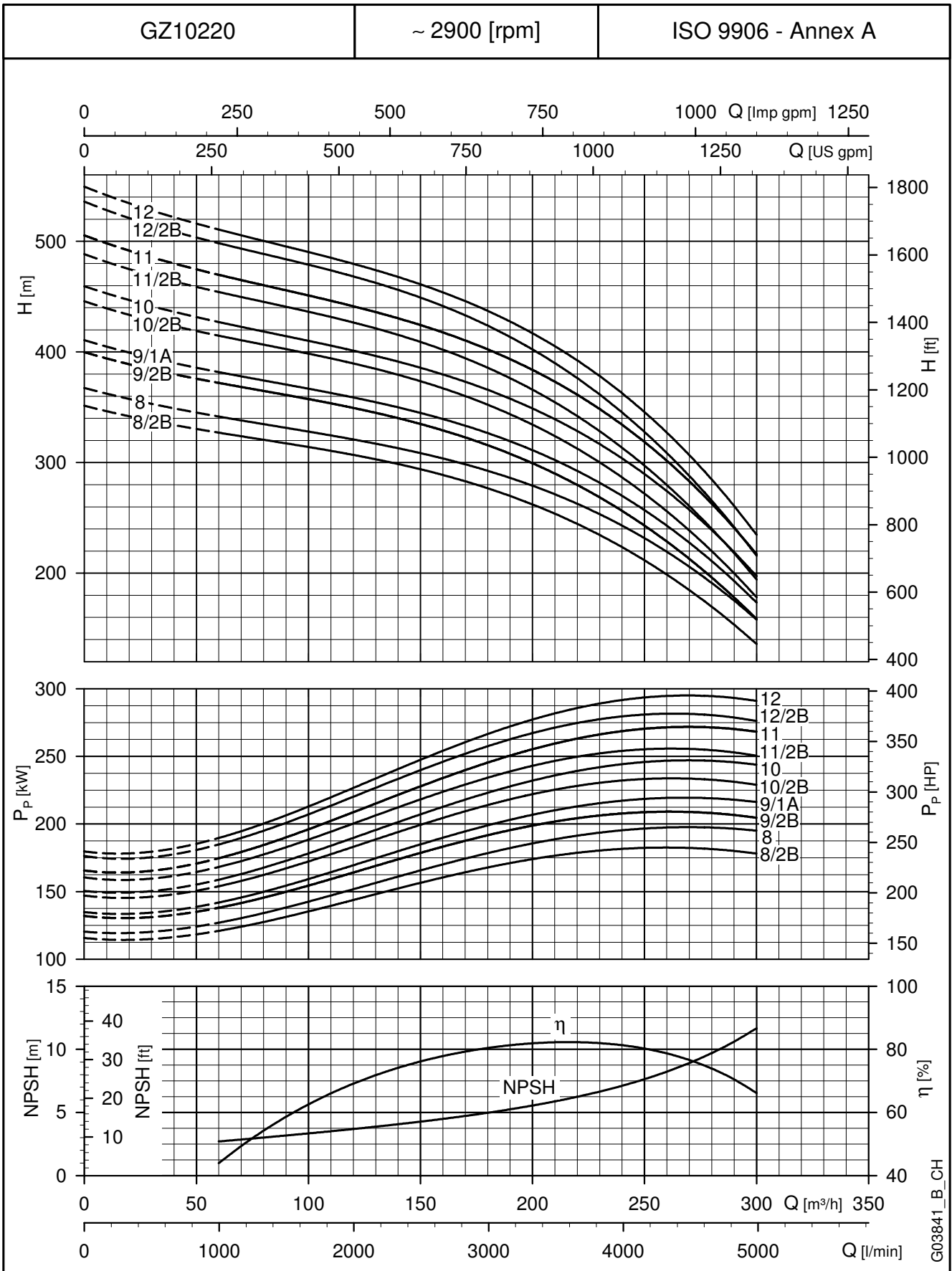

These performances are valid for liquids with density  $\rho = 1.0 \text{ Kg/dm}^3$  and kinematic viscosity  $\nu = 1 \text{ mm}^2/\text{sec}$ .

## GZ10275 SERIES, 1 TO 3 STAGES OPERATING CHARACTERISTICS AT 50 Hz

PUMP TYPE	RATED POWER	Q = DELIVERY						
		l/min	0	1333	2500	3667	4667	5833
		m <sup>3</sup> /h	0	80	150	220	280	350
kW		H = TOTAL HEAD METRES COLUMN OF WATER						
GZ10275 01/1B	18,5	33	29,7	26,6	22,6	16,5		
GZ10275 01/1A	22	37,5	34,1	31	27,5	22,2	12,3	
GZ10275 01	30	41,6	38,6	35,9	32,6	28,5	18,6	
GZ10275 02/2B	37	67	60,3	54	46,1	34		
GZ10275 02/2A	45	75,7	69,2	62,9	56	45,4	26	
GZ10275 02	55	82,6	76,7	71	64,6	56,4	36,5	
GZ10275 03/2B	60	107,8	98,3	89,2	78	61,8		
GZ10275 03/3A	67	113,6	103,8	94,3	84,1	68,2	39	
GZ10275 03/1A	75	120,5	111,3	102,6	92,5	79	50	
GZ10275 03	83	123,9	115,1	106,8	97	84,6	54,8	

gz10275-2p50-1-en\_a\_th

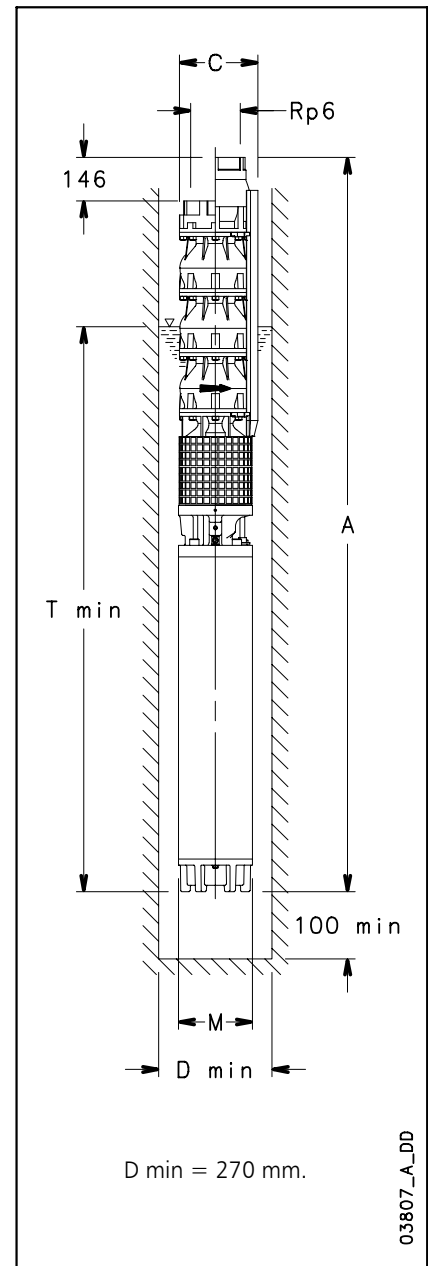

## DIMENSIONS AND WEIGHTS

PUMP TYPE	RATED POWER	DIMENSIONS (mm)				WEIGHT
		A (4)	C (1)	M	T (2)	
GZ10275 01/1B-CP6W	18,5	1608	258	144	3803	122
GZ10275 01/1A-CP6W	22	1648	258	144	3843	125
GZ10275 01-CP6W	30	1856	258	144	4051	142
GZ10275 02/2B-CP6W	37	2172	258	144	4151	180
GZ10275 02/2A-CP8W	45	2116	258	192	4095	248
GZ10275 02-CP8W	55	2246	258	192	4225	274
GZ10275 03/2B-CP8W	60	2512	258	192	4275	304
GZ10275 03/3A-CP8W	67	2602	258	192	4365	322
GZ10275 03/1A-CP8W	75	2692	258	192	4455	339
GZ10275 03-CP8W	83	2752	258	192	4515	352

gz10275-2p50-1-en\_a\_td

- 1) Max electric pump diameter with 2 motor cables included.  
In case of 1 motor cable C = 255 mm with CP6W motor.  
C = 255 mm with CP8W motor.
- 2) T min valid only for max flow speed of 4,5 m/s between pump and perforation pipe.  
In case this velocity is exceeded, please contact our sales network.
- 3) Without cables.
- 4) For pumps without non-return valve, reduce dimension A by 146 mm, and reduce weight by 8,8 Kg.

**GZ10275 SERIES, 1 TO 3 STAGES  
OPERATING CHARACTERISTICS AT 50 Hz**

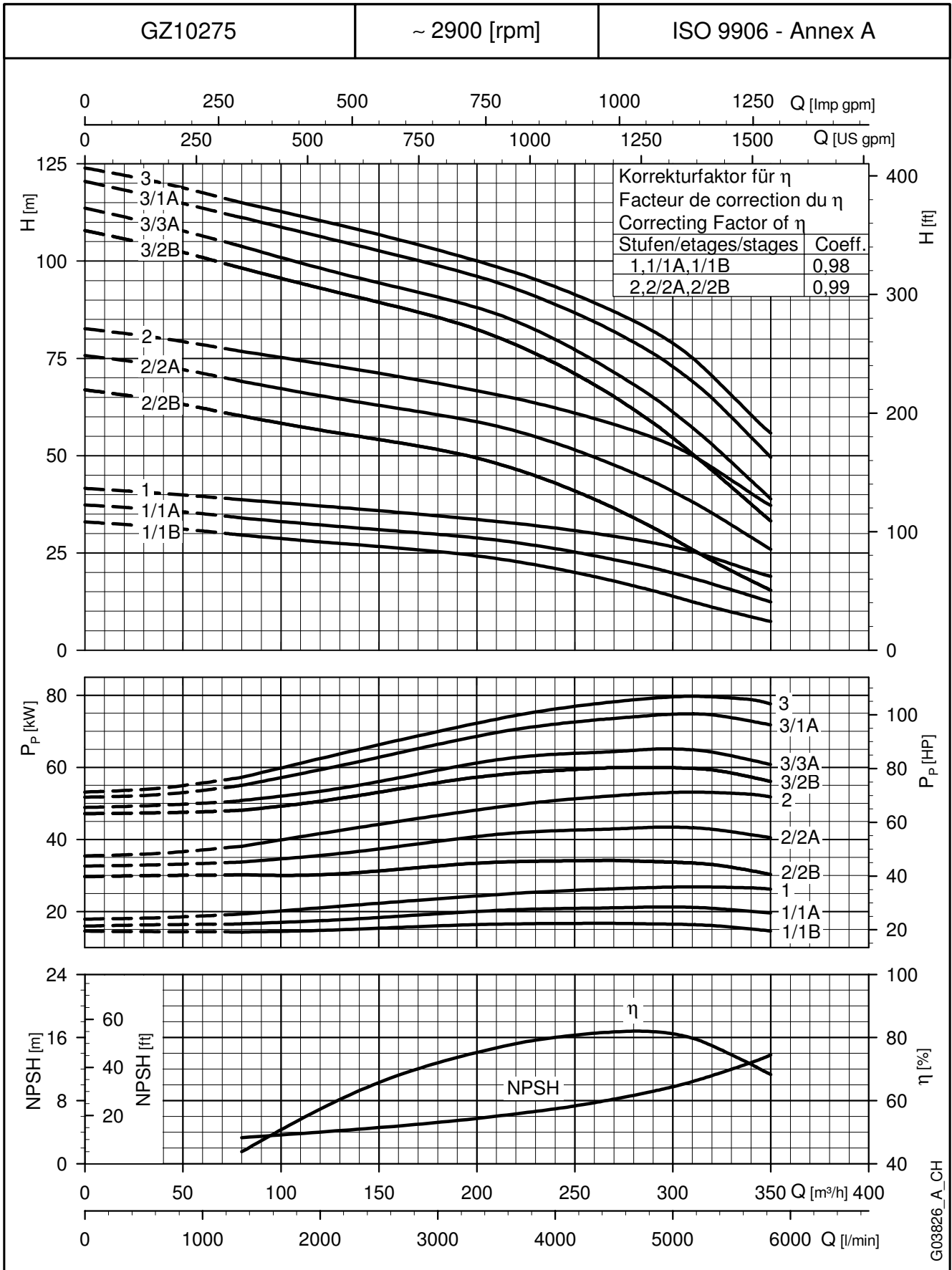

These performances are valid for liquids with density  $\rho = 1.0 \text{ Kg/dm}^3$  and kinematic viscosity  $\nu = 1 \text{ mm}^2/\text{sec}$ .

**GZ10275 SERIES, 4 TO 7 STAGES  
OPERATING CHARACTERISTICS AT 50 Hz**

PUMP TYPE	RATED POWER	Q = DELIVERY						
		l/min	0	1333	2500	3667	4667	5833
		m <sup>3</sup> /h	0	80	150	220	280	350
kW		H = TOTAL HEAD METRES COLUMN OF WATER						
GZ10275 04/3A	93,0	154	142	130	116	96	58	
GZ10275 04/2A	110	162	150	138	124	105	67	
GZ10275 04	110	169	157	146	132	116	77	
GZ10275 05/3A	130	202	186	171	154	130	82	
GZ10275 05	150	212	197	183	167	146	98	
GZ10275 06/3A	150	242	224	206	186	157	100	
GZ10275 06	185	253	235	218	199	174	116	
GZ10275 07/2A	185	288	267	246	223	192	124	
GZ10275 07	185	297	276	257	233	205	138	

gz10275-2p50-2-en\_a\_th

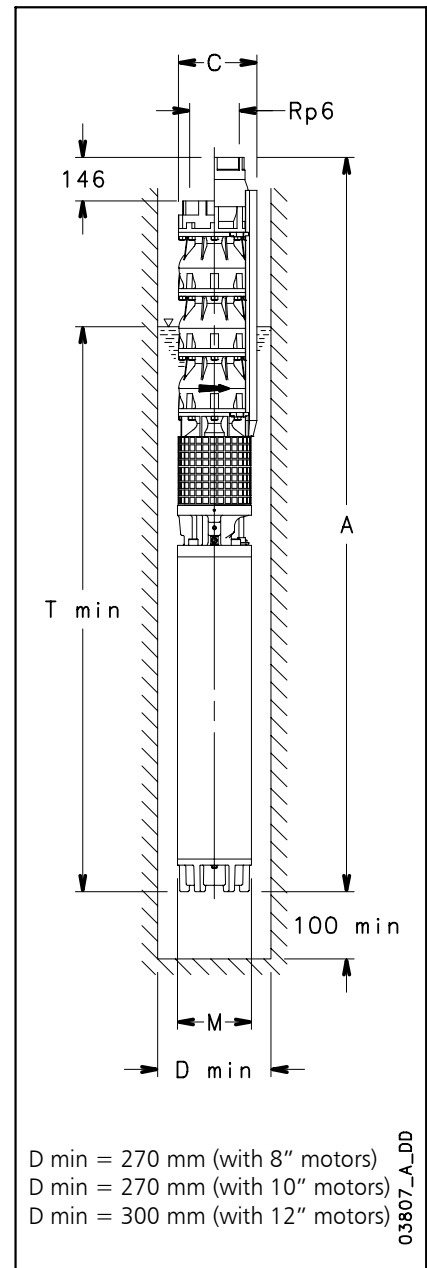

gz10275-2p50-2-en\_a\_td

**DIMENSIONS AND WEIGHT**

PUMP TYPE	RATED POWER	DIMENSIONS (mm)				WEIGHT
		A (4)	C (1)	M	T (2)	
GZ10275 04/3A-CP8W	93	3108	258	192	4655	397
GZ10275 04/2A-CP10W	110	3092	259	236	4602	513
GZ10275 04-CP10W	110	3092	259	236	4602	513
GZ10275 05/3A-CP10W	130	3458	259	236	4752	579
GZ10275 05-CP10W	150	3588	259	236	4882	618
GZ10275 06/3A-CP10W	150	3804	259	236	4882	638
GZ10275 06-CP12W	185	3561	283	276	4639	703
GZ10275 07/2A-CP12W	185	3777	283	276	4639	723
GZ10275 07-CP12W	185	3777	283	276	4639	723

- 1) Max electric pump diameter with 2 motor cables included.  
In case of 1 motor cable C = 255 mm with CP8W motor.  
C = 255 mm with CP10W motor and C = 280 mm with CP12W motor.
- 2) T min valid only for max flow speed of 4,5 m/s between pump and perforation pipe.  
In case this velocity is exceeded, please contact our sales network.
- 3) Without cables.
- 4) For pumps without non-return valve, reduce dimension A by 146 mm, and reduce weight by 8,8 Kg.

**GZ10275 SERIES, 4 TO 7 STAGES  
OPERATING CHARACTERISTICS AT 50 Hz**

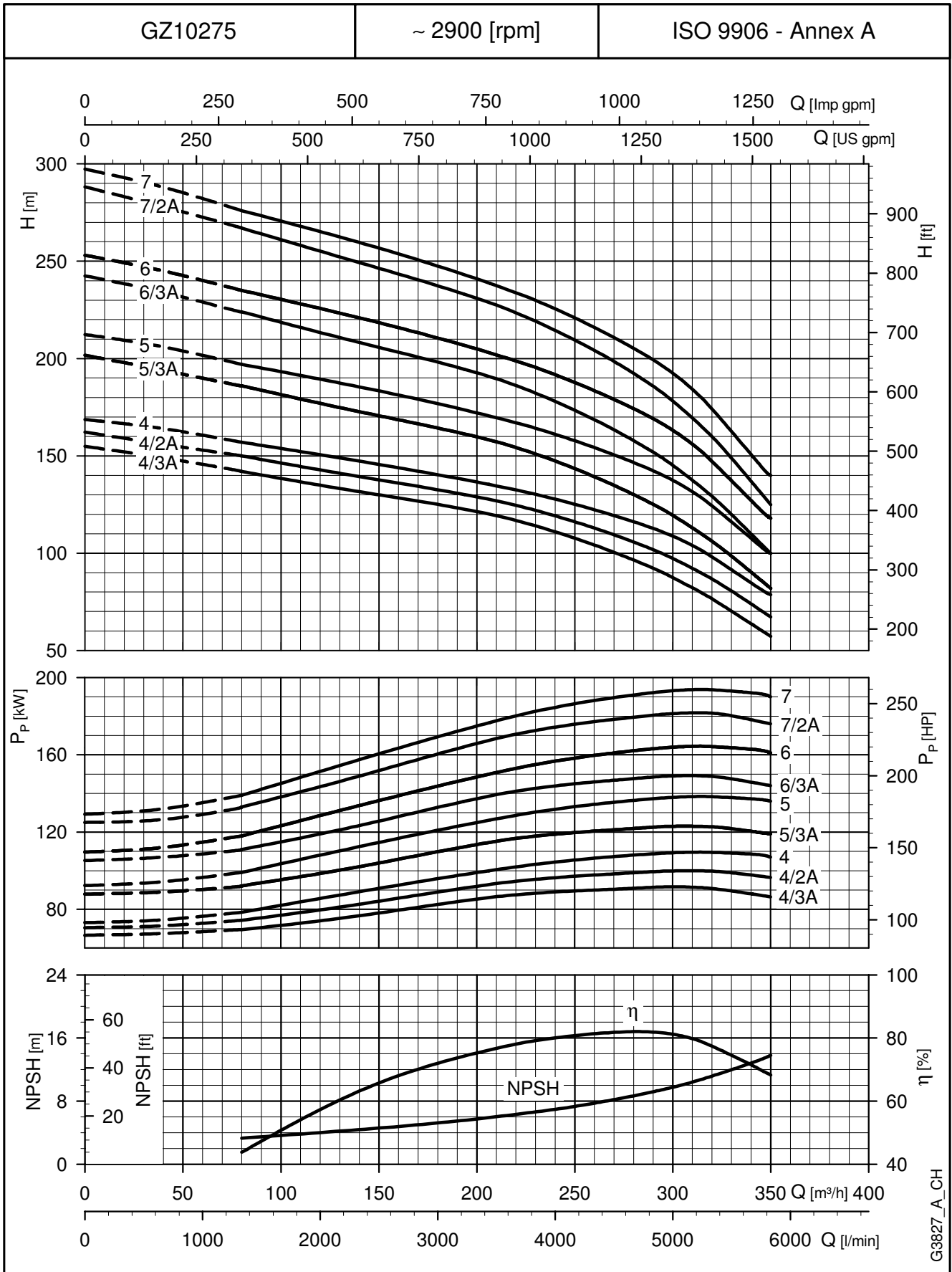

These performances are valid for liquids with density  $\rho = 1.0 \text{ Kg/dm}^3$  and kinematic viscosity  $\nu = 1 \text{ mm}^2/\text{sec}$ .

**GZ10275 SERIES, 8 TO 11 STAGES  
OPERATING CHARACTERISTICS AT 50 Hz**

PUMP TYPE	RATED POWER	Q = DELIVERY						
		l/min	0	1333	2500	3667	4667	5833
		m <sup>3</sup> /h	0	80	150	220	280	350
kW		H = TOTAL HEAD METRES COLUMN OF WATER						
GZ10275 08/2B	220	324	299	276	248	217	143	
GZ10275 08/1A	220	336	312	289	263	229	152	
GZ10275 09/3A	260	372	344	317	287	247	160	
GZ10275 09	260	382	355	330	300	264	177	
GZ10275 10/3A	260	413	382	352	319	275	179	
GZ10275 10	300	426	396	368	335	294	199	
GZ10275 11/1A	300	464	430	399	363	316	211	

gz10275-2p50-3-en\_a\_th

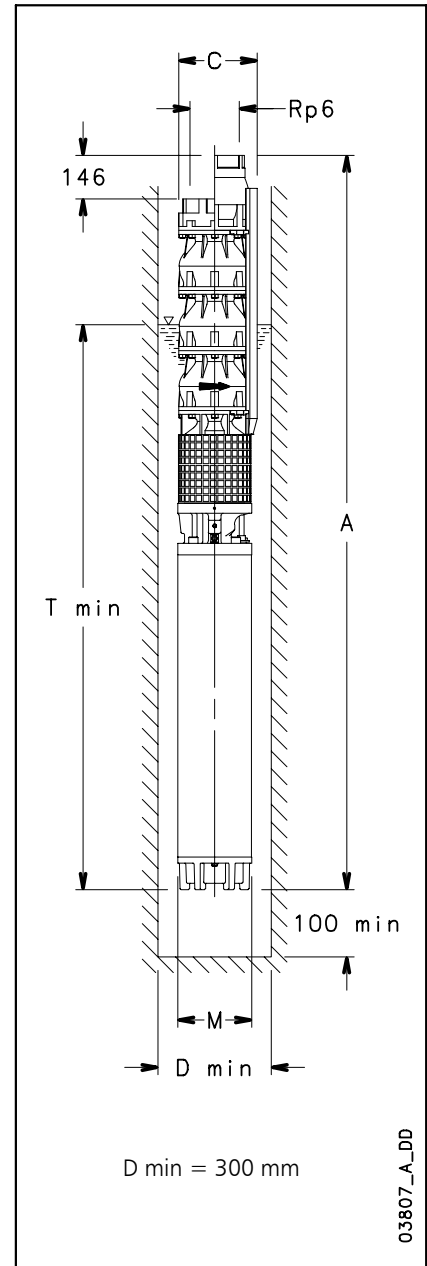

**DIMENSIONS AND WEIGHTS**

PUMP TYPE	RATED POWER	DIMENSIONS (mm)				WEIGHT
		A (4)	C (1)	M	T (2)	
	kW					kg (3)
GZ10275 08/2B-CP12W	220	4143	283	276	4789	806
GZ10275 08/1A-CP12W	220	4143	283	276	4789	806
GZ10275 09/3A-CP12W	260	4509	283	276	4939	890
GZ10275 09-CP12W	260	4509	283	276	4939	890
GZ10275 10/3A-CP12W	260	4725	283	276	4939	909
GZ10275 10-CP12W	300	4875	283	276	5089	974
GZ10275 11/1A-CP12W	300	5091	283	276	5089	994

gz10275-2p50-3-en\_a\_td

- 1) Max electric pump diameter with 2 motor cables included.  
In case of 1 motor cable C = 280 mm with CP12W motor.
- 2) T min valid only for max flow speed of 4,5 m/s between pump and perforation pipe.  
In case this velocity is exceeded, please contact our sales network.
- 3) Without cables.
- 4) For pumps without non-return valve, reduce dimension A by 146 mm, and reduce weight by 8,8 Kg.



**GZ10275 SERIES, 8 TO 11 STAGES  
OPERATING CHARACTERISTICS AT 50 Hz**

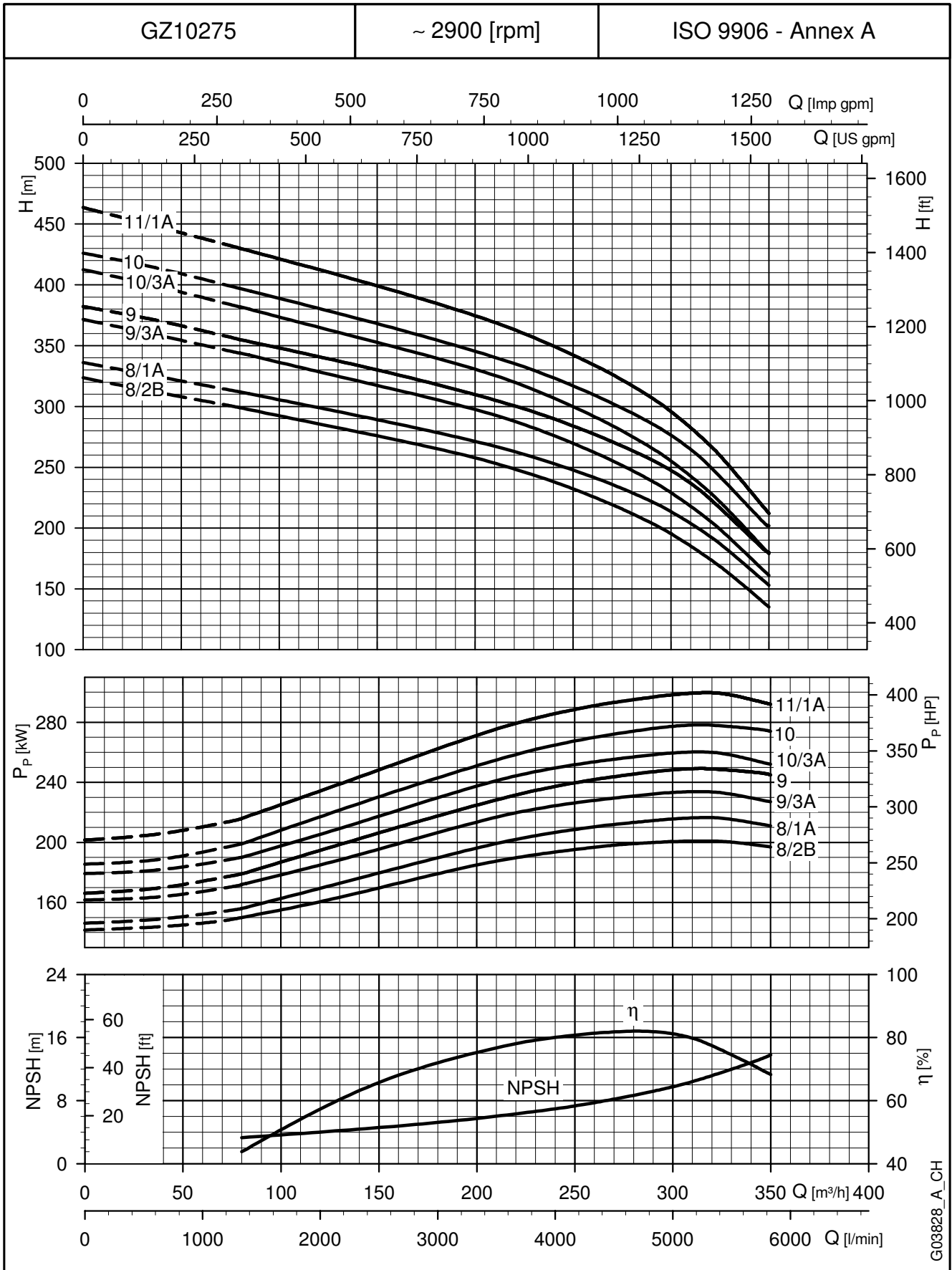

These performances are valid for liquids with density  $\rho = 1.0 \text{ Kg/dm}^3$  and kinematic viscosity  $\nu = 1 \text{ mm}^2/\text{sec}$ .

## GZ10150 PUMP SERIES DIMENSIONS AND WEIGHTS

PUMP TYPE	MAX POWER ABSORBED BY PUMP kW	DIMENSIONS (mm)			WEIGHT kg <sup>(3)</sup>	Ø MIN. WELL mm
		L <sup>(4)</sup>	C <sup>(1)</sup>	U <sup>(2)</sup>		
GZ10150 01/1C-6	10,3	442	258	1600	48,1	270
GZ10150 01/1B-6	12,8	442	258	1600	48,1	270
GZ10150 01/1A-6	14,8	442	258	1600	48,1	270
GZ10150 02/2C-6	20,5	658	258	1600	68,8	270
GZ10150 02/2B-6	25,7	658	258	1600	68,8	270
GZ10150 02/2A-6	29,6	658	258	1600	68,8	270
GZ10150 03/2C-6	36,2	874	258	1600	89,5	270
GZ10150 03/2B-8	41,3	874	258	1600	89,8	270
GZ10150 03/2A-8	44,4	874	258	1600	89,8	270
GZ10150 03-8	46,9	874	258	1600	89,8	270
GZ10150 04/2C-8	51,8	1090	258	1600	110,5	270
GZ10150 04/2B-8	57,0	1090	258	1600	110,5	270
GZ10150 04-8	62,6	1090	258	1600	110,5	270
GZ10150 05/2C-8	67,4	1306	258	1600	131,2	270
GZ10150 05/2B-8	72,6	1306	258	1600	131,2	270
GZ10150 05-8	78,2	1306	258	1600	131,2	270
GZ10150 06/2C-8	83,0	1522	258	1600	151,9	270
GZ10150 06/1B-8	91,0	1522	258	1600	151,9	270
GZ10150 06-10	93,8	1522	258	1600	156,8	270
GZ10150 07/3B-10	101,1	1738	258	1600	177,5	270
GZ10150 07/1B-10	106,7	1738	258	1600	177,5	270
GZ10150 08/3B-10	116,7	1954	258	1600	198,2	270
GZ10150 08-10	125,1	1954	258	1600	198,2	270
GZ10150 09/3B-10	132,4	2170	258	1600	218,9	270
GZ10150 09-10	140,8	2170	258	1600	218,9	270
GZ10150 10-12	156,4	2386	271	1600	240,4	300
GZ10150 11-12	172,0	2602	271	1600	261,1	300
GZ10150 12-12	187,7	2818	271	1600	281,8	300

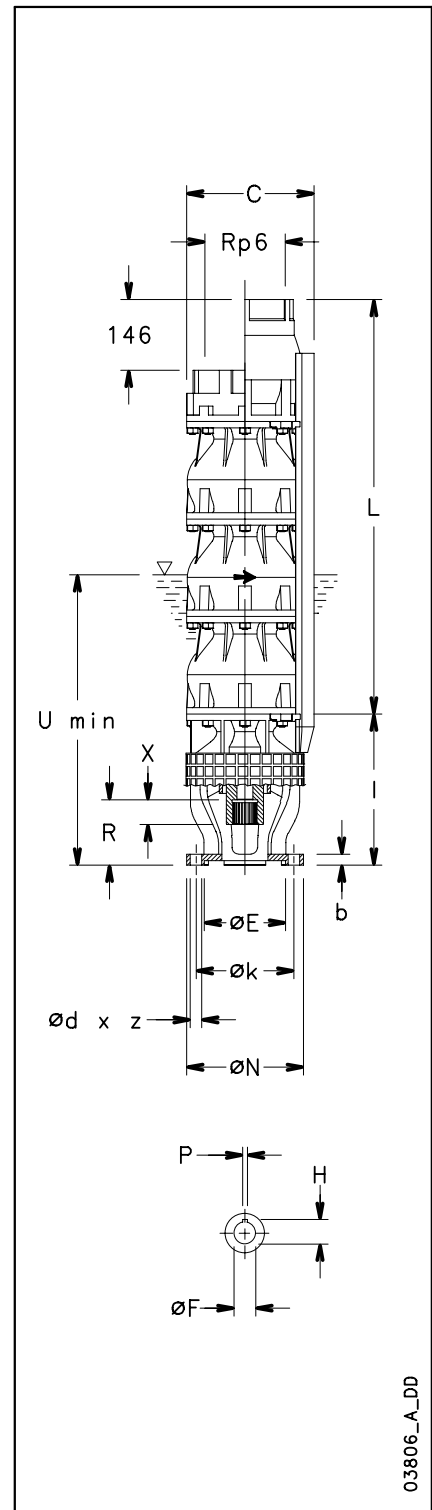

## MOTOR COUPLING

gz10150p-50\_b\_td

MOTOR CONNECTION	DIMENSIONS (mm)							
	N	k	d	z	b	E <sup>H7</sup>	R	I
6" (NEMA)	182	111,2	13,5	4	17	76,2	73	263
8" (NEMA)	182	152,4	18	4	17	127	101,45	263
10"	232	190,5	22	4	15	127	101,45	300
12"	232	190,5	22	4	15	127	126,85	300

COUPLING	DIMENSIONS (mm)			
	Profile of gear coupling according to NEMA			
	NUMBER OF TEETH	DIAMETRICAL PITCH	PRESSURE ANGLE	X
6" (NEMA)	15	16/32	30°	20
8" (NEMA)	23	16/32	30°	38

COUPLING	DIMENSIONS (mm)			
	F <sup>+0.084 +0.059</sup>	H <sup>+0.1</sup>	P <sup>+0.05 +0.02</sup>	X
10"	42,85	47,6	9,5	84
12"	49,212	54,5	12,7	95

z10-mtcn-50-en\_b\_td

03806\_A\_DD

- 1) Max pump diameter with 2 motor cables included.
- 2) U min valid only for max flow speed of 4,5 m/s between pump and perforation pipe.
- 3) Weight with non-return valve. For pumps without non-return valve, reduce by 8,3 Kg.
- 4) For pumps without non-return valve, reduce dimension L by 146 mm.

## GZ10220 PUMP SERIES DIMENSIONS AND WEIGHTS

PUMP TYPE	MAX POWER ABSORBED BY PUMP kW	DIMENSIONS (mm)			WEIGHT kg <sup>(3)</sup>	Ø MIN. WELL mm
		L <sup>(4)</sup>	C <sup>(1)</sup>	U <sup>(2)</sup>		
GZ10220 01/1C-6	14,6	442	258	2900	47,3	270
GZ10220 01/1B-6	18,0	442	258	2900	47,3	270
GZ10220 01/1A-6	21,5	442	258	2900	47,3	270
GZ10220 01-6	24,0	442	258	2900	47,3	270
GZ10220 02/2C-6	29,2	658	258	2900	66,6	270
GZ10220 02/2B-6	36,0	658	258	2900	66,6	270
GZ10220 02/2A-8	43,0	658	258	2900	66,9	270
GZ10220 02-8	48,0	658	258	2900	66,9	270
GZ10220 03/2B-8	60,0	874	258	2900	86,2	270
GZ10220 03/2A-8	67,0	874	258	2900	86,2	270
GZ10220 03-8	72,0	874	258	2900	86,2	270
GZ10220 04/2B-8	84,0	1090	258	2900	105,5	270
GZ10220 04/2A-8	91,0	1090	258	2900	105,5	270
GZ10220 04-10	96,0	1090	258	2900	110,4	270
GZ10220 05/2B-10	108,0	1306	258	2900	129,7	270
GZ10220 05-10	120,0	1306	258	2900	129,7	270
GZ10220 06/2B-10	132,0	1522	258	2900	149	270
GZ10220 06-10	144,0	1522	258	2900	149	270
GZ10220 07/2B-12	156,0	1738	271	2900	169,1	300
GZ10220 07-12	168,0	1738	271	2900	169,1	300
GZ10220 08/2B-12	180,0	1954	271	2900	188,4	300
GZ10220 08-12	192,0	1954	271	2900	188,4	300
GZ10220 09/2B-12	204,0	2170	271	2900	207,7	300
GZ10220 09/1A-12	213,5	2170	271	2900	207,7	300
GZ10220 10/2B-12	228,0	2386	271	2900	227	300
GZ10220 10-12	240,0	2386	271	2900	227	300
GZ10220 11/2B-12	252,0	2602	271	2900	246,3	300
GZ10220 11-12	264,0	2602	271	2900	246,3	300
GZ10220 12/2B-12	276,0	2818	271	2900	265,6	300
GZ10220 12-12	288,0	2818	271	2900	265,6	300

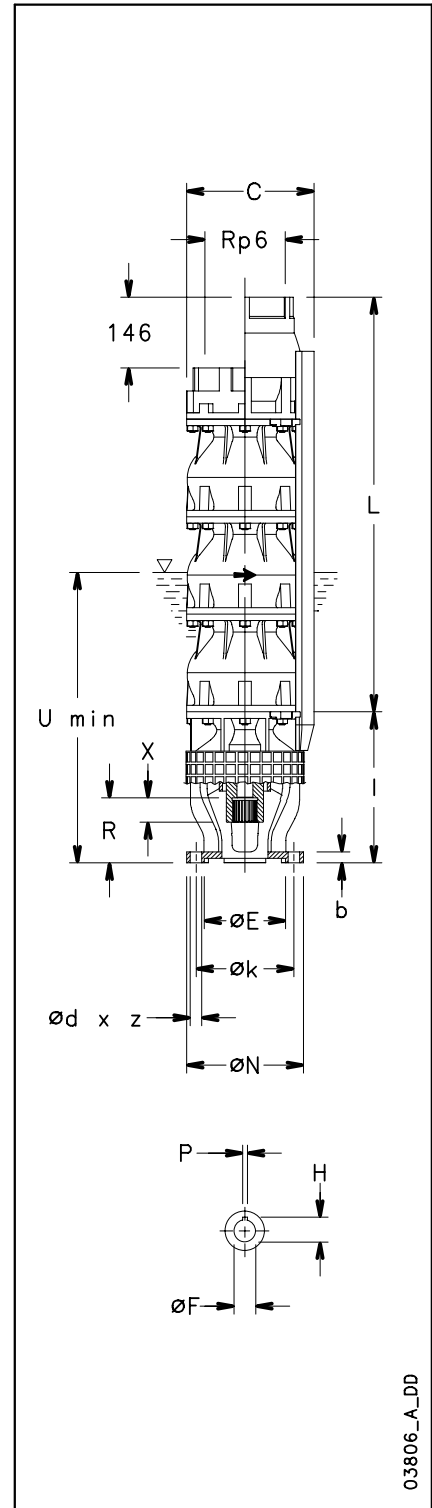

03806\_A\_DD

### MOTOR COUPLING

gz10220p-50-en\_b\_td

MOTOR CONNECTION	DIMENSIONS (mm)							
	N	k	d	z	b	E <sup>H7</sup>	R	I
6" (NEMA)	182	111,2	13,5	4	17	76,2	73	263
8" (NEMA)	182	152,4	18	4	17	127	101,45	263
10"	232	190,5	22	4	15	127	101,45	300
12"	232	190,5	22	4	15	127	126,85	300

COUPLING	DIMENSIONS (mm)			
	Profile of gear coupling according to NEMA			
	NUMBER OF TEETH	DIAMETRAL PITCH	PRESSURE ANGLE	X
6" (NEMA)	15	16/32	30°	20
8" (NEMA)	23	16/32	30°	38

COUPLING	DIMENSIONS (mm)			
	F <sup>+0.084 +0.059</sup>	H <sup>+0.1</sup>	P <sup>+0.05 +0.02</sup>	X
10"	42,85	47,6	9,5	84
12"	49,212	54,5	12,7	95

z10-mtcn-50-en\_b\_td

- 1) Max pump diameter with 2 motor cables included.
- 2) U min valid only for max flow speed of 4,5 m/s between pump and perforation pipe.
- 3) Weight with non-return valve. For pumps without non-return valve, reduce by 8,3 Kg.
- 4) For pumps without non-return valve, reduce dimension L by 146 mm.

## GZ10275 PUMP SERIES DIMENSIONS AND WEIGHTS

PUMP TYPE	MAX POWER ABSORBED BY PUMP kW	DIMENSIONS (mm)			WEIGHT kg <sup>(3)</sup>	Ø MIN. WELL mm
		L <sup>(4)</sup>	C <sup>(1)</sup>	U <sup>(2)</sup>		
GZ10275 01/1B-6	17,3	442	258	2900	47,4	270
GZ10275 01/1A-6	21,9	442	258	2900	47,4	270
GZ10275 01-6	26,9	442	258	2900	47,4	270
GZ10275 02/2B-6	34,6	658	258	2900	66,9	270
GZ10275 02/2A-8	43,8	658	258	2900	67,2	270
GZ10275 02-8	53,8	658	258	2900	67,2	270
GZ10275 03/2B-8	61,5	874	258	2900	86,7	270
GZ10275 03/3A-8	65,7	874	258	2900	86,7	270
GZ10275 03/1A-8	75,7	874	258	2900	86,7	270
GZ10275 03-8	80,7	874	258	2900	86,7	270
GZ10275 04/3A-8	92,6	1090	258	2900	106,2	270
GZ10275 04/2A-10	97,6	1090	258	2900	111,1	270
GZ10275 04-10	107,6	1090	258	2900	111,1	270
GZ10275 05/3A-10	119,5	1306	258	2900	130,6	270
GZ10275 05-10	134,5	1306	258	2900	130,6	270
GZ10275 06/3A-10	146,4	1522	258	2900	150,1	270
GZ10275 06-12	161,4	1522	271	2900	150,1	300
GZ10275 07/2A-12	178,3	1738	271	2900	170,4	300
GZ10275 07-12	188,3	1738	271	2900	170,4	300
GZ10275 08/2B-12	196,0	1954	271	2900	189,9	300
GZ10275 08/1A-12	210,2	1954	271	2900	189,9	300
GZ10275 09/3A-12	227,1	2170	271	2900	209,4	300
GZ10275 09-12	242,1	2170	271	2900	209,4	300
GZ10275 10/3A-12	254,0	2386	271	2900	228,9	300
GZ10275 10-12	269,0	2386	271	2900	228,9	300
GZ10275 11/1A-12	290,9	2602	271	2900	248,4	300

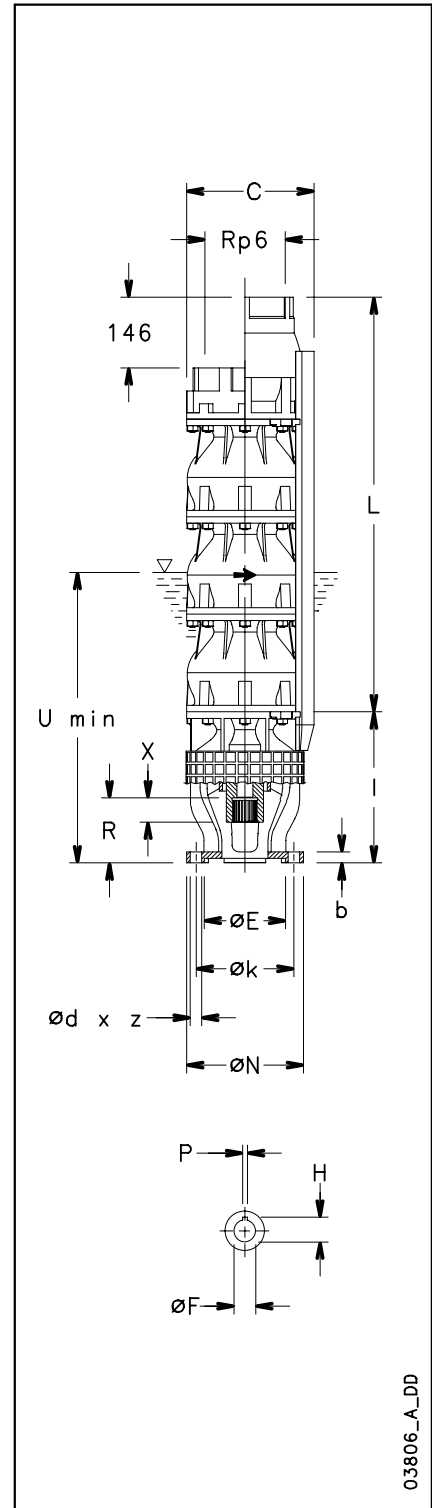

03806\_A\_DD

## MOTOR COUPLING

gz10275p-50-en\_b\_td

MOTOR CONNECTION	DIMENSIONS (mm)							
	N	k	d	z	b	E <sup>H7</sup>	R	I
6" (NEMA)	182	111,2	13,5	4	17	76,2	73	263
8" (NEMA)	182	152,4	18	4	17	127	101,45	263
10"	232	190,5	22	4	15	127	101,45	300
12"	232	190,5	22	4	15	127	126,85	300

COUPLING	DIMENSIONS (mm)			
	Profile of gear coupling according to NEMA			
	NUMBER OF TEETH	DIAMETRICAL PITCH	PRESSURE ANGLE	X
6" (NEMA)	15	16/32	30°	20
8" (NEMA)	23	16/32	30°	38

  

COUPLING	DIMENSIONS (mm)			
	F <sup>+0.084 +0.059</sup>	H <sup>+0.1</sup>	P <sup>+0.05 +0.02</sup>	X
10"	42,85	47,6	9,5	84
12"	49,212	54,5	12,7	95

z10-mtcn-50-en\_b\_td

- 1) Max pump diameter with 2 motor cables included.
- 2) U min valid only for max flow speed of 4,5 m/s between pump and perforation pipe.
- 3) Weight with non-return valve. For pumps without non-return valve, reduce by 8,8 Kg.
- 4) For pumps without non-return valve, reduce dimension L by 146 mm.

**GZ10 SERIES  
 PUMP CROSS SECTION AND LIST OF COMPONENTS**

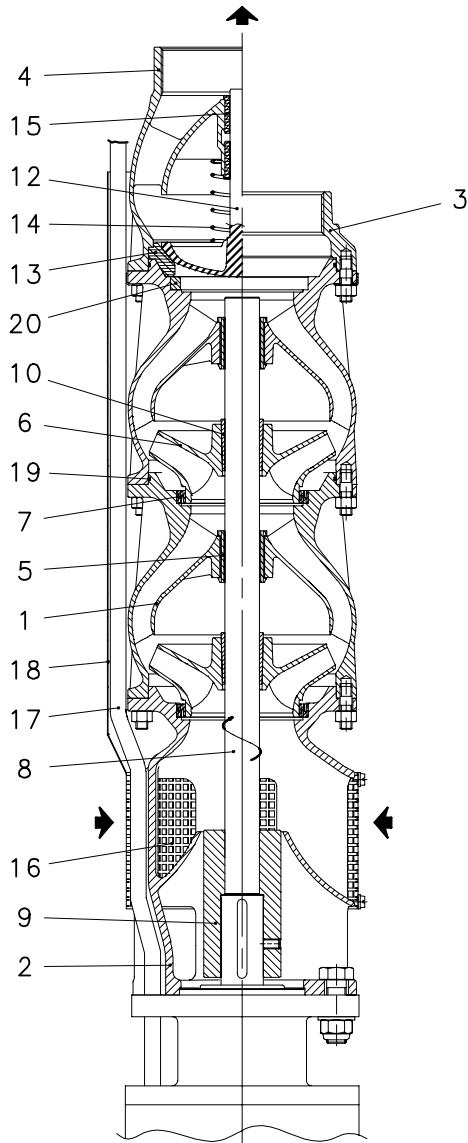

MOT. CP10W

REF. N.	DESCRIPTION
1	Stage casing
2	Suction casing
3	Delivery casing
4	Valve body
5	Bearing bush
6	Impeller
7	Wear ring
8	Shaft
9	Coupling
10	Locking sleeve
11	Thrust bearing
12	Valve plate
13	Valve seat
14	Valve spring
15	Wing valve
16	Suction strainer
17	Cable
18	Cable protection
19	O-ring
20	Intermediate ring

z10-2p50-en\_a\_tp

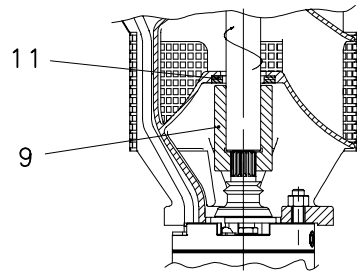

MOT. CP6W  
 ( 6" NEMA )

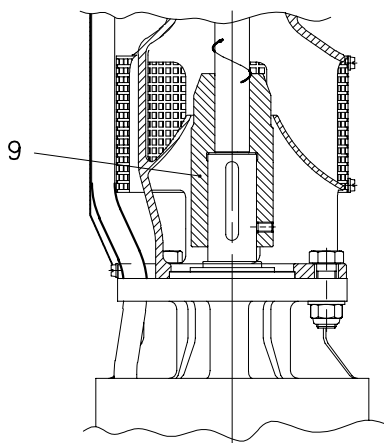

MOT. CP12W

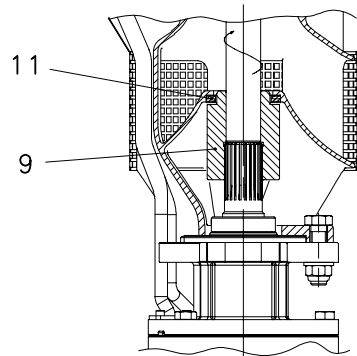

MOT. CP8W  
 ( 8" NEMA )

03801\_A\_DS



## 12" Submersible Electric Pumps

### GZ12340 GZ12420 Series



#### MARKET SECTORS

AGRICULTURAL, INDUSTRIAL, MUNICIPAL.

#### APPLICATIONS

- Water supply from deep wells.
- Pressure boosting and water distribution in civil and industrial systems.
- Supply of surge tanks and reservoirs.
- Firefighting and washing systems.
- Water table level control.
- Irrigation.

#### SPECIFICATIONS

##### PUMP

- **Delivery:** up to 520 m<sup>3</sup>/h.
- **Head:** up to 450 m.
- Maximum pump overall diameter (2 cable covers included): 302 mm.
- Maximum electric pump immersion depth: 350 m with CP8W, CP10W and CP12W motors.
- The content of sand should not exceed 50 g/m<sup>3</sup>, higher contents up to 100 g/m<sup>3</sup> can be admitted, if wear is tolerated.
- Horizontal installation possible (it is recommended to have an incline of at least 3° with the motor on the lowest position).
- Standard delivery outlet: 8" NPT according to API.
- Motor power: from 30 to 350 kW.
- Electric pumps with powers up to 300 kW are supplied with CentriPro motor series. For larger powers please contact our sales network.

##### MOTOR

- CP8W, CP10W and CP12W rewindable water filled three-phase motors.
- **Three-phase version:**  
CP8W: 30 to 93 kW 380-415 V, 50 Hz.  
CP10W: 93 to 150 kW 380-415 V, 50 Hz.  
CP12W: 185 to 300 kW 380-415 V, 50 Hz.
- Maximum supply voltage variations: CP8W, CP10W, CP12W 400V ±10%.
- **Horizontal operation:**  
CP8W, CP10W and CP12W all versions are designed for horizontal installation, provided that the direction of the axial thrust generated by the impellers is always from the pump to the motor.

- Maximum number of starts per hour: 10 (CP8W) 8 (CP10W) 4 (CP12W).
- Maximum temperature of water in contact with motor: CP8W, CP10W and CP12W 30°C.
- **Special versions: AISI 316 and Duplex materials, HT** for applications in high temperature environments (up to 60°C) or under inverter.

#### CONSTRUCTION

##### FEATURES

##### PUMP

- Robust but lightweight, easy to maintain and with high corrosion resistance.
- **Impeller** and **diffusers** made of stainless steel castings.
- Delivery head and suction support of stainless steel castings.
- Stainless steel non return valve integrated, spring equipped.
- Stainless steel shaft.
- Guide bearings and wear rings ensure high reliability and long lasting hydraulic performances.
- The new design ensures high efficiency and low power consumption.
- **Special versions:** GZR12 made of **Duplex** stainless steel.
- Coupling according to **NEMA** standard for 8" motor, with key connection for 10" and 12" motor.

#### ACCESSORIES

- Coupling flange.
- Panels.
- Drop cables.
- Cooling shrouds.
- Temperature sensor **PT 100 / PTC**.

## TABLE OF MATERIALS GZ12

COMPONENT	MATERIAL	DESIGNATION	
		EUROPE	USA
Delivery head / Valve Casing	Stainless steel	EN 10213-4-GX5CrNi19-10 (1.4308)	A744-CF 8
Valve	Stainless steel	EN 10213-4-GX5CrNi19-10 (1.4308)	A744-CF 8
Valve seat	NBR 90		
Valve spring	Stainless steel	EN 10088-1-X5CrNiMo17-12-2 (1.4401)	AISI 316
Diffuser / Bowl	Stainless steel	EN 10213-4-GX5CrNi19-10 (1.4308)	A744-CF 8
Diffuser O-Ring	NBR 70		
Impeller	Stainless steel	EN 10213-4-GX5CrNi19-10 (1.4308)	A744-CF 8
Taperlock	Duplex stainless steel	EN 10088-1-X2CrNiMoN22-5-3 (1.4462)	A276/A790-S31803
Wear ring	POM		
Lower support / Suction Casing	Stainless steel	EN 10213-4-GX5CrNi19-10 (1.4308)	A744-CF 8
Suction strainer	Stainless steel	DIN 17440-X6CrNiMoTi17-12-2 (1.4571)	AISI 316Ti
Pump shaft	Stainless steel	EN 10088-1-X17CrNi16-2 (1.4057)	AISI 431
Coupling	Duplex stainless steel	EN 10088-1-X2CrNiMoN22-5-3 (1.4462)	A276/A790-S31803
Bearing bush	EPDM + LOXAMID <sup>®</sup>		
Thrust Bearing	PTFE + 25% carbon		
Screw, stud, nut	Stainless steel	ISO 3506-1/2 A4-70	AISI 316
Cable protection	Stainless steel	EN 10088-1-X5CrNi18-10 (1.4301)	AISI 304

zr12-2p50-en\_b\_tm

## TABLE OF MATERIALS GZR12

COMPONENT	MATERIAL	DESIGNATION	
		EUROPE	USA
Delivery head / Valve Casing	Duplex stainless steel	EN 10213-4-GX2CrNiMoCuN25-6-3-3 (1.4517)	
Valve	Duplex stainless steel	EN 10213-4-GX2CrNiMoCuN25-6-3-3 (1.4517)	
Valve seat	NBR 90		
Valve spring	Hastelloy C4	DIN17744-NiMo16Cr16Ti (2.4610)	N06455
Diffuser / Bowl	Duplex stainless steel	EN 10213-4-GX2CrNiMoCuN25-6-3-3 (1.4517)	
Diffuser O-Ring	NBR 70		
Impeller	Duplex stainless steel	EN 10213-4-GX2CrNiMoCuN25-6-3-3 (1.4517)	
Taperlock	Duplex stainless steel	EN 10088-1-X2CrNiMoN22-5-3 (1.4462)	A276/A790-S31803
Wear ring	POM		
Lower support / Suction Casing	Duplex stainless steel	EN 10213-4-GX2CrNiMoCuN25-6-3-3 (1.4517)	
Suction strainer	Stainless steel	EN 10088-1X1NiCrMoCu25-20-5 (1.4539)	AISI 904L
Pump shaft	Duplex stainless steel	EN 10088-1-X2CrNiMoN22-5-3 (1.4462)	A276/A790-S31803
Coupling	Duplex stainless steel	EN 10088-1-X2CrNiMoN22-5-3 (1.4462)	A276/A790-S31803
Bearing bush	EPDM + LOXAMID <sup>®</sup>		
Thrust Bearing	PTFE + 25% carbon		
Screw, stud, nut	Duplex stainless steel	EN 10088-1-X2CrNiMoN22-5-3 (1.4462)	A276/A790-S31803
Cable protection	Stainless steel	EN 10088-1X1NiCrMoCu25-20-5 (1.4539)	AISI 904L

zr12-2p50-en\_a\_tm

## IDENTIFICATION CODE

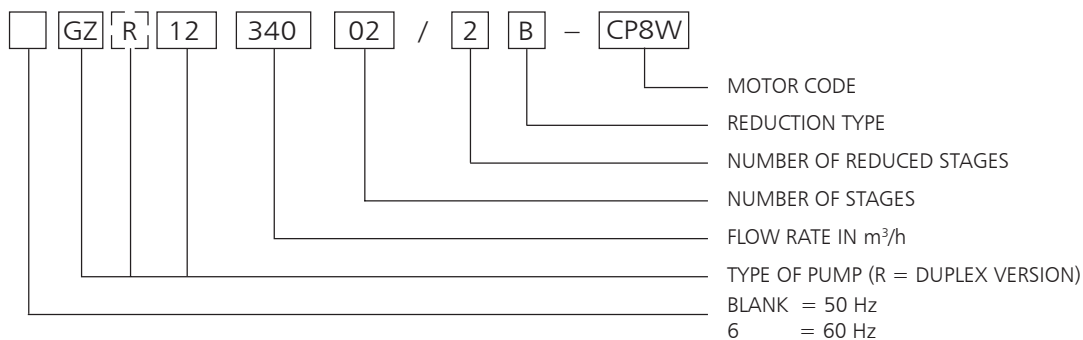

EXAMPLE : GZR12 340 02/2B - CP8W  
 12" electric pump, 50 Hz, made of DUPLEX, flow rate 340 m<sup>3</sup>/h, 2 stages including 2 reduced ones, coupled to an 8" CP8W motor.



**GZ12 SERIES  
 HYDRAULIC PERFORMANCE RANGE AT 50 Hz**

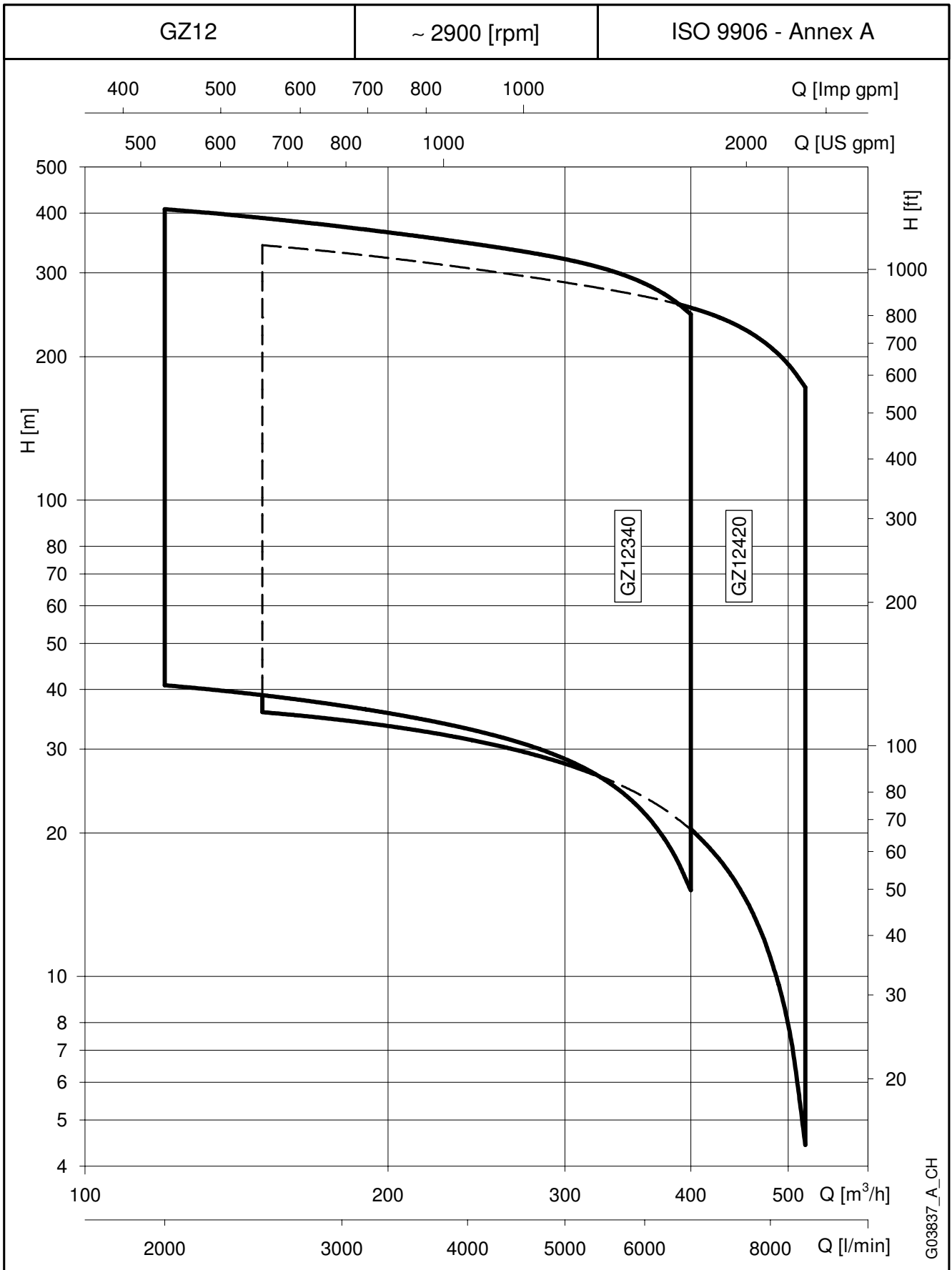

**GZ12340 SERIES, 1 TO 2 STAGES  
OPERATING CHARACTERISTICS AT 50 Hz**

PUMP TYPE	RATED POWER	Q = DELIVERY						
		l/min	0	2000	3333	4667	5667	6667
		m <sup>3</sup> /h	0	120	200	280	340	400
kW		H = TOTAL HEAD METRES COLUMN OF WATER						
GZ12340 01/1B	30	45,5	41,1	35,5	30,1	24,5	15,2	
GZ12340 01/1A	37	50,0	44,8	39,6	34,8	29,7	21,1	
GZ12340 01	45	55,4	49,8	44,7	40,0	36,2	28,9	
GZ12340 02/2C	52	82,7	75,6	63,8	52,2	39,2	20,0	
GZ12340 02/2B	60	90,3	81,5	70,5	60,1	48,4	29,1	
GZ12340 02/2A	75	100,6	90,3	79,8	70,1	60,1	43,0	
GZ12340 02	93	110,7	99,6	89,3	79,9	72,5	57,8	

gz12340-2p50-1-en\_a\_th

**DIMENSIONS AND WEIGHTS**

PUMP TYPE	RATED POWER	DIMENSIONS (mm)				WEIGHT
		A (4)	C (1)	M	T (2)	
	kW					kg (3)
GZ12340 01/1B-CP8W	30	1765	290	192	3915	217
GZ12340 01/1A-CP8W	37	1855	290	192	4005	234
GZ12340 01-CP8W	45	1945	290	192	4095	252
GZ12340 02/2C-CP8W	52	2270	290	192	4185	300
GZ12340 02/2B-CP8W	60	2360	290	192	4275	317
GZ12340 02/2A-CP8W	75	2540	290	192	4455	352
GZ12340 02-CP8W	93	2740	290	192	4655	390

gz12340-2p50-1-en\_a\_td

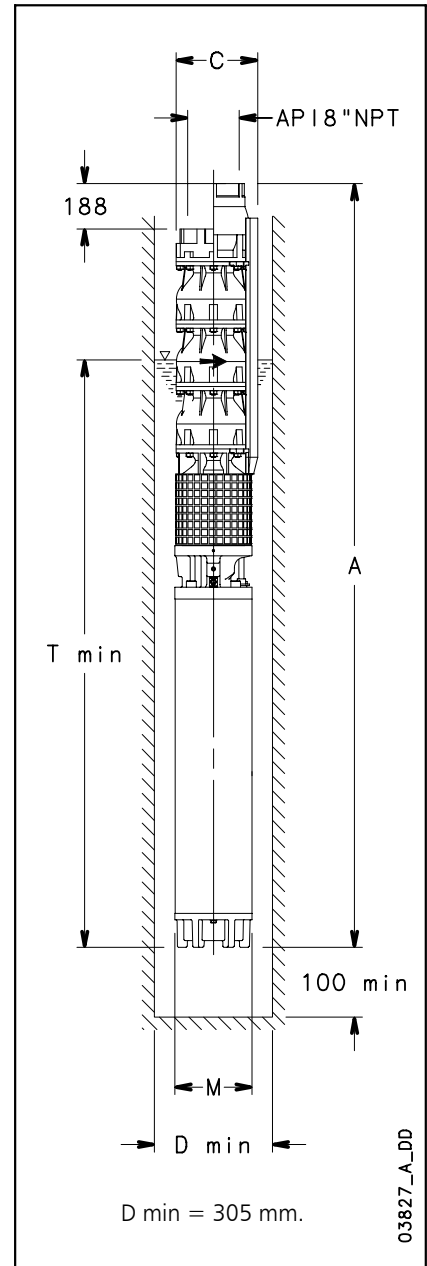

03827\_A\_DD

D min = 305 mm.

- 1) Max electric pump diameter with 2 motor cables included.  
In case of 1 motor cable C = 285 mm with CP8W motor.
- 2) T min valid only for max flow speed of 6,8 m/s between pump and perforation pipe.  
In case this velocity is exceeded, please contact our sales network.
- 3) Without cables.
- 4) For pumps without non-return valve, reduce dimension A by 188 mm, and reduce weight by 16,7 Kg.

**GZ12340 SERIES, 1 TO 2 STAGES  
OPERATING CHARACTERISTICS AT 50 Hz**

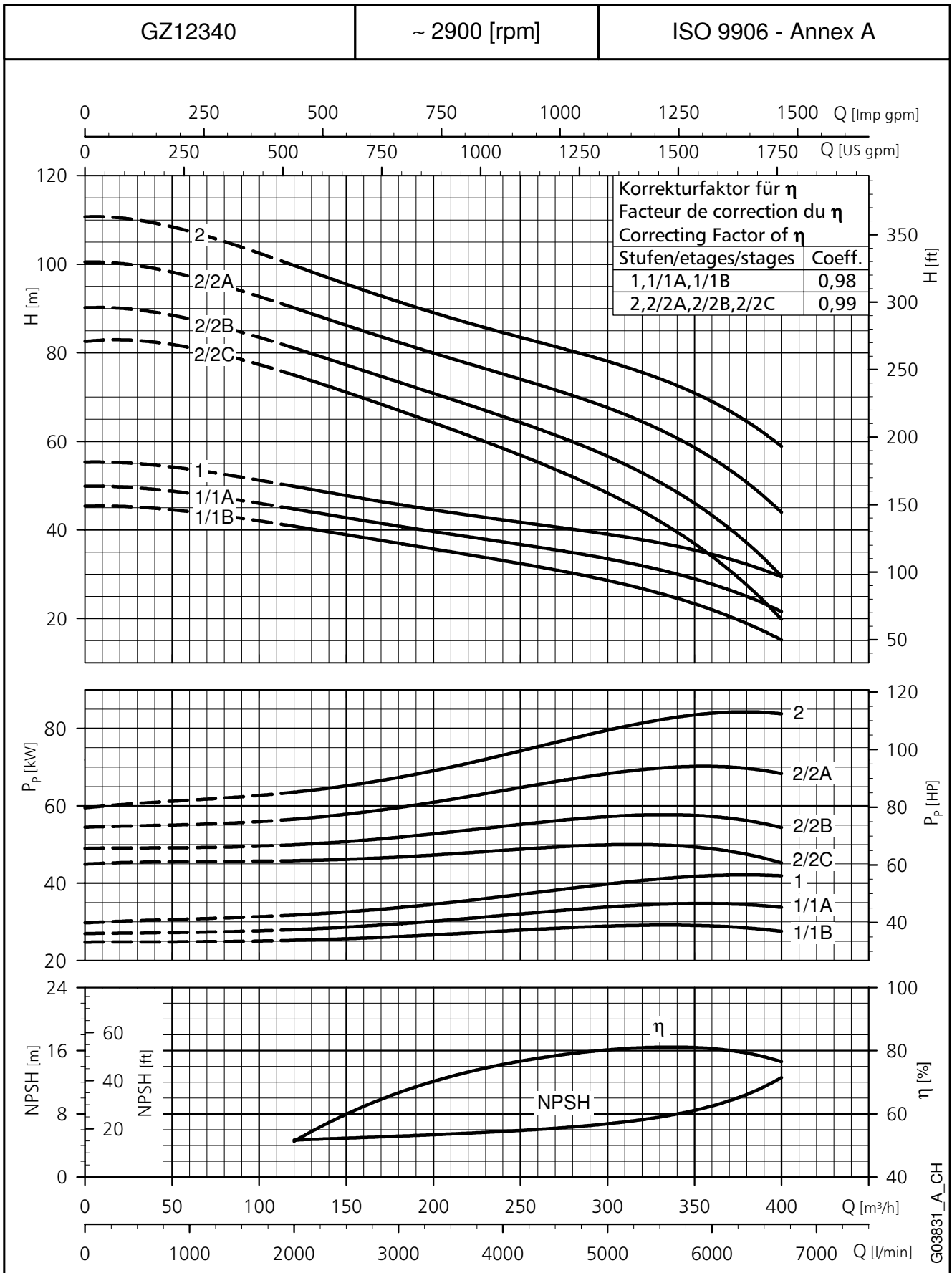

These performances are valid for liquids with density  $\rho = 1.0 \text{ Kg/dm}^3$  and kinematic viscosity  $\nu = 1 \text{ mm}^2/\text{sec}$ .

**GZ12340 SERIES, 3 TO 4 STAGES  
OPERATING CHARACTERISTICS AT 50 Hz**

PUMP TYPE	RATED POWER	Q = DELIVERY						
		l/min	0	2000	3333	4667	5667	6667
		m <sup>3</sup> /h	0	120	200	280	340	400
kW		H = TOTAL HEAD METRES COLUMN OF WATER						
GZ12340 03/2C	110	137	124	107	91	74	49	
GZ12340 03/3A	110	153	137	122	107	92	67	
GZ12340 03/1A	130	163	147	131	117	104	81	
GZ12340 03	150	169	153	137	122	112	90	
GZ12340 04/2B	150	204	185	163	143	125	92	
GZ12340 04/2A	185	214	194	172	153	135	104	
GZ12340 04	185	225	202	182	162	148	119	

gz12340-2p50-2-en\_a\_th

**DIMENSIONS AND WEIGHTS**

PUMP TYPE	RATED POWER	DIMENSIONS (mm)				WEIGHT
		A (4)	C (1)	M	T (2)	
GZ12340 03/2C-CP10W	110	2982	302	236	4602	531
GZ12340 03/3A-CP10W	110	2982	302	236	4602	531
GZ12340 03/1A-CP10W	130	3132	302	236	4752	578
GZ12340 03-CP10W	150	3262	302	236	4882	617
GZ12340 04/2B-CP10W	150	3497	302	236	4882	644
GZ12340 04/2A-CP12W	185	3254	306	276	4639	710
GZ12340 04-CP12W	185	3254	306	276	4639	710

gz12340-2p50-2-en\_a\_td

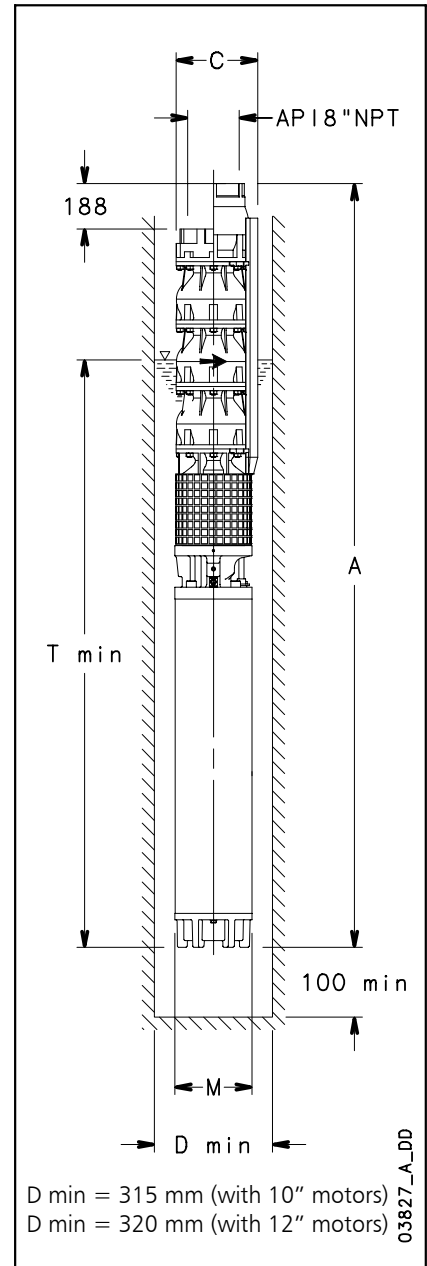

- 1) Max electric pump diameter with 2 motor cables included.  
In case of 1 motor cable C = 293 mm with CP10W motor.  
C = 300 mm with CP12W motor.
- 2) T min valid only for max flow speed of 6,8 m/s between pump and perforation pipe.  
In case this velocity is exceeded, please contact our sales network.
- 3) Without cables.
- 4) For pumps without non-return valve, reduce dimension A by 188 mm, and reduce weight by 16,7 Kg.

**GZ12340 SERIES, 3 TO 4 STAGES  
OPERATING CHARACTERISTICS AT 50 Hz**

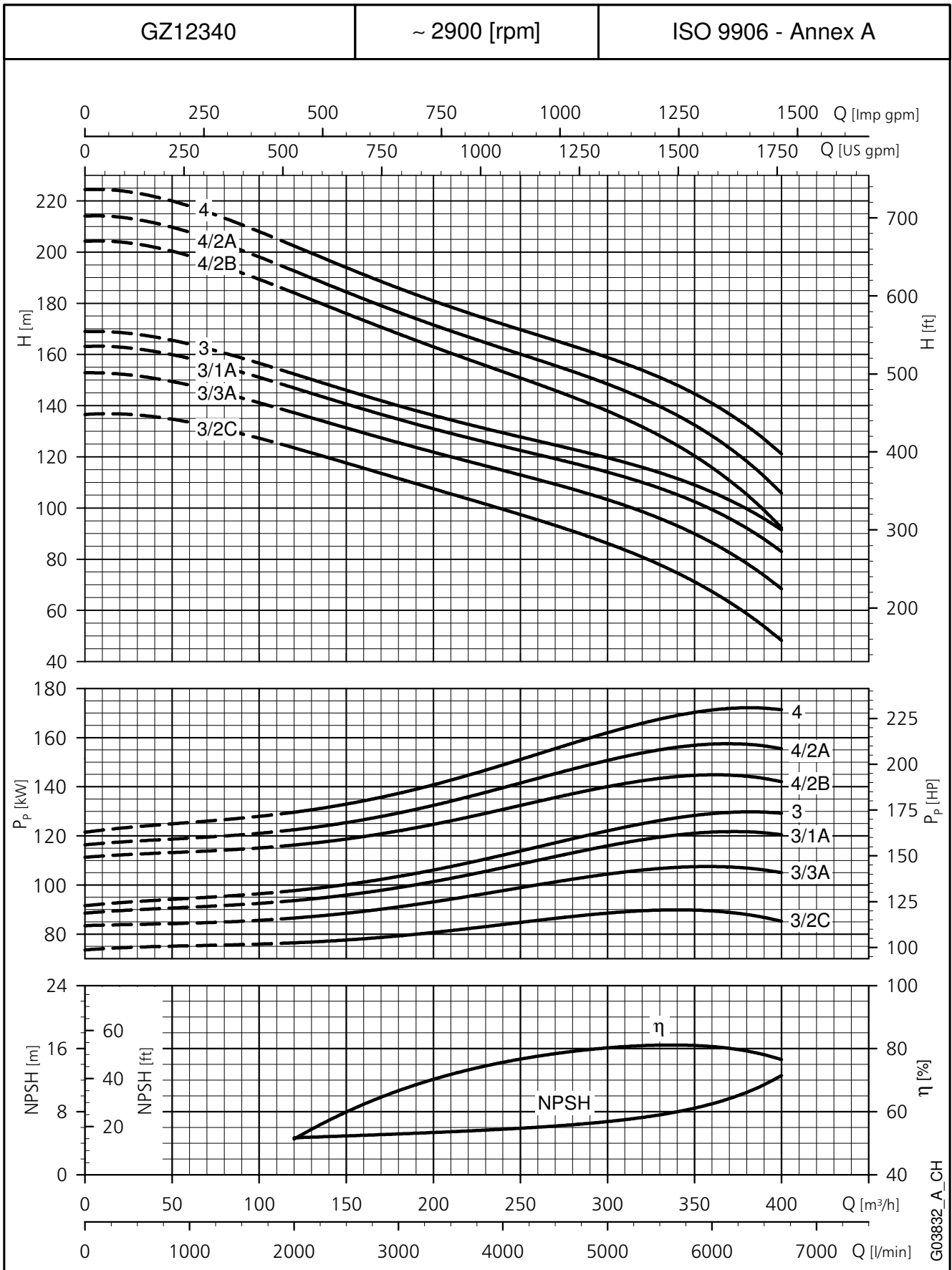

These performances are valid for liquids with density  $\rho = 1.0 \text{ Kg/dm}^3$  and kinematic viscosity  $\nu = 1 \text{ mm}^2/\text{sec}$ .

**GZ12340 SERIES, 5 TO 8 STAGES  
OPERATING CHARACTERISTICS AT 50 Hz**

PUMP TYPE	RATED POWER	Q = DELIVERY						
		l/min	0	2000	3333	4667	5667	6667
		m <sup>3</sup> /h	0	120	200	280	340	400
kW		H = TOTAL HEAD METRES COLUMN OF WATER						
GZ12340 05/2B	220	262	237	210	185	163	124	
GZ12340 05/2A	220	272	245	219	195	174	135	
GZ12340 05	220	283	255	229	205	187	152	
GZ12340 06/2B	260	319	288	256	226	201	155	
GZ12340 06/2A	260	329	297	265	236	211	165	
GZ12340 06	260	339	306	274	246	224	182	
GZ12340 07/3A	300	379	341	304	271	241	187	
GZ12340 07	300	396	357	320	286	262	212	
GZ12340 08/3A	350	437	393	351	313	279	218	
GZ12340 08	350	452	408	366	327	299	242	

gz12340-2p50-3-en\_a\_th

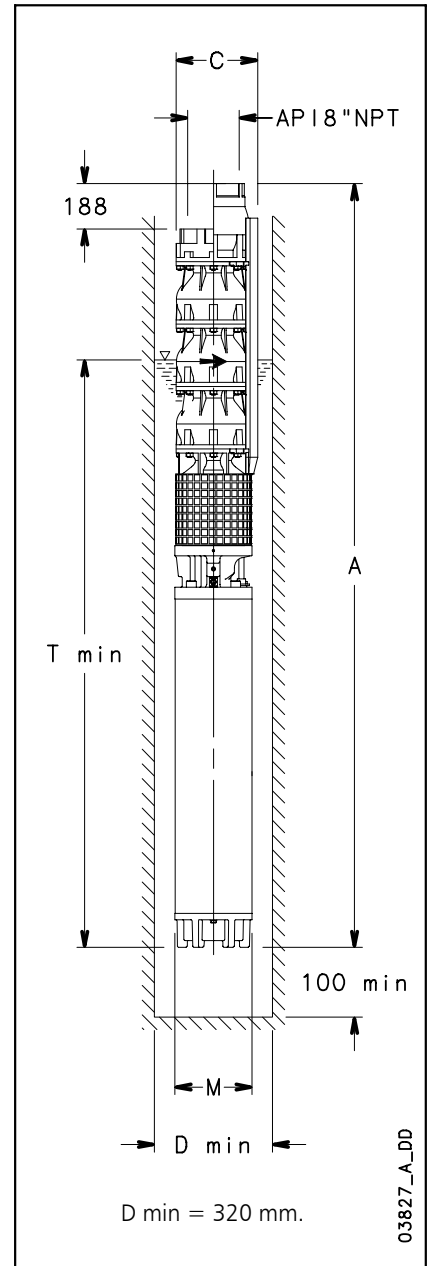

**DIMENSIONS AND WEIGHTS**

PUMP TYPE	RATED POWER	DIMENSIONS (mm)				WEIGHT
		A (4)	C (1)	M	T (2)	
	kW					kg (3)
GZ12340 05/2B-CP12W	220	3639	306	276	4789	801
GZ12340 05/2A-CP12W	220	3639	306	276	4789	801
GZ12340 05-CP12W	220	3639	306	276	4789	801
GZ12340 06/2B-CP12W	260	4024	306	276	4939	893
GZ12340 06/2A-CP12W	260	4024	306	276	4939	893
GZ12340 06-CP12W	260	4024	306	276	4939	893
GZ12340 07/3A-CP12W	300	4409	306	276	5089	985
GZ12340 07-CP12W	300	4409	306	276	5089	985
GZ12340 08/3A-**	350	-	-	-	-	-
GZ12340 08-**	350	-	-	-	-	-

\*\* For power above 350 kW please contact our sales network.

gz12340-2p50-3-en\_a\_td

- 1) Max electric pump diameter with 2 motor cables included.  
In case of 1 motor cable C = 300 mm with CP12W motor.
- 2) T min valid only for max flow speed of 6,8 m/s between pump and perforation pipe.  
In case this velocity is exceeded, please contact our sales network.
- 3) Without cables.
- 4) For pumps without non-return valve, reduce dimension A by 188 mm, and reduce weight by 16,7 Kg.

**GZ12340 SERIES, 5 TO 8 STAGES  
 OPERATING CHARACTERISTICS AT 50 Hz**

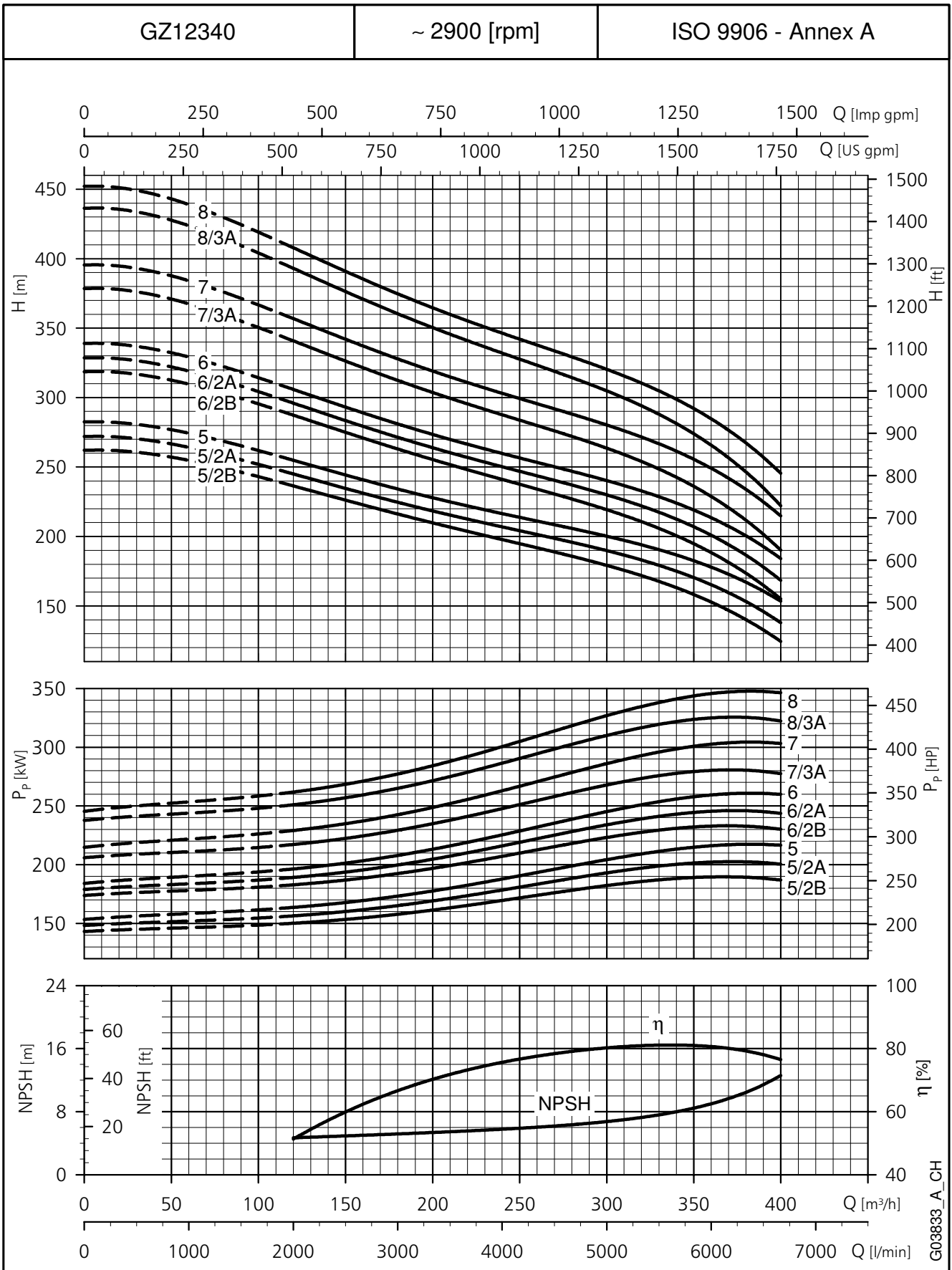

These performances are valid for liquids with density  $\rho = 1.0 \text{ Kg/dm}^3$  and kinematic viscosity  $\nu = 1 \text{ mm}^2/\text{sec}$ .

**GZ12420 SERIES, 1 TO 2 STAGES  
OPERATING CHARACTERISTICS AT 50 Hz**

PUMP TYPE	RATED POWER	Q = DELIVERY						
		l/min	0	2500	4167	5833	7000	8667
		m <sup>3</sup> /h	0	150	250	350	420	520
kW		H = TOTAL HEAD METRES COLUMN OF WATER						
GZ12420 01/1C	30	38,8	36,1	30,8	24,7	18,3		
GZ12420 01/1B	37	44,1	40,1	35,1	29,6	24,5	12,0	
GZ12420 01/1A	45	49,3	45,0	39,6	34,4	30,5	18,8	
GZ12420 01	52	52,2	47,7	42,3	37,0	33,9	22,3	
GZ12420 02/2C	60	77,1	71,7	61,0	48,9	36,0		
GZ12420 02/2B	75	88,7	80,8	70,8	59,7	49,7	24,0	
GZ12420 02/2A	93	99,3	90,7	79,9	69,3	61,6	38,9	
GZ12420 02	110	106,5	97,6	86,6	75,9	69,9	47,3	

gz12420-2p50-1-en\_a\_th

**DIMENSIONS AND WEIGHTS**

PUMP TYPE	RATED POWER	DIMENSIONS (mm)				WEIGHT
		A (4)	C (1)	M	T (2)	
	kW					kg (3)
GZ12420 01/1C-CP8W	30	1765	290	192	3915	217
GZ12420 01/1B-CP8W	37	1855	290	192	4005	234
GZ12420 01/1A-CP8W	45	1945	290	192	4095	252
GZ12420 01-CP8W	52	2035	290	192	4185	272
GZ12420 02/2C-CP8W	60	2360	290	192	4275	317
GZ12420 02/2B-CP8W	75	2540	290	192	4455	352
GZ12420 02/2A-CP8W	93	2740	290	192	4655	390
GZ12420 02-CP10W	110	2747	302	236	4602	504

gz12420-2p50-1-en\_a\_td

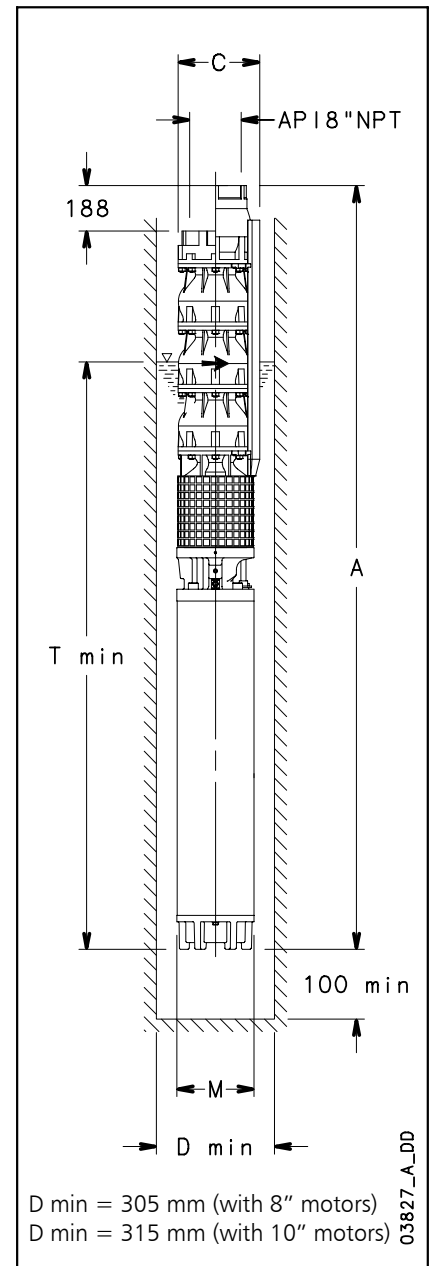

D min = 305 mm (with 8" motors)

D min = 315 mm (with 10" motors)

03827\_A\_DD

- 1) Max electric pump diameter with 2 motor cables included.  
In case of 1 motor cable C = 285 mm with CP8W motor.  
C = 293 mm with CP10W motor.
- 2) T min valid only for max flow speed of 6,8 m/s between pump and perforation pipe.  
In case this velocity is exceeded, please contact our sales network.
- 3) Without cables.
- 4) For pumps without non-return valve, reduce dimension A by 188 mm, and reduce weight by 16,7 Kg.



**GZ12420 SERIES, 1 TO 2 STAGES  
OPERATING CHARACTERISTICS AT 50 Hz**

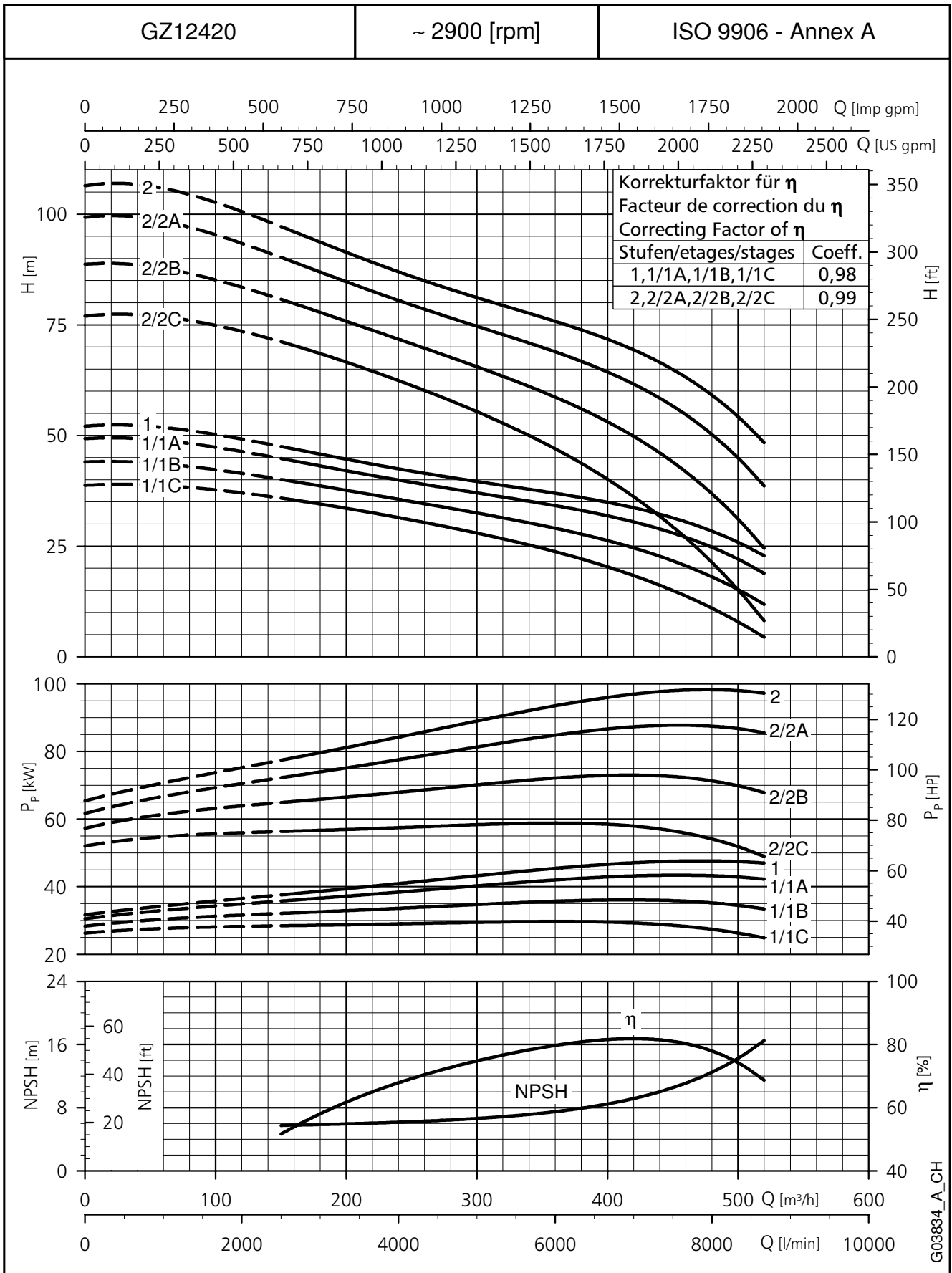

These performances are valid for liquids with density  $\rho = 1.0 \text{ Kg/dm}^3$  and kinematic viscosity  $\nu = 1 \text{ mm}^2/\text{sec}$ .

**GZ12420 SERIES, 3 TO 4 STAGES  
OPERATING CHARACTERISTICS AT 50 Hz**

PUMP TYPE	RATED POWER	Q = DELIVERY						
		l/min	0	2500	4167	5833	7000	8667
		m <sup>3</sup> /h	0	150	250	350	420	520
kW		H = TOTAL HEAD METRES COLUMN OF WATER						
GZ12420 03/2C	110	132	122	106	89	72	36	
GZ12420 03/2B	130	143	132	115	99	85	50	
GZ12420 03/3A	150	151	138	122	106	94	60	
GZ12420 03	150	160	146	130	114	104	71	
GZ12420 04/3B	185	188	173	151	129	111	64	
GZ12420 04/3A	185	204	187	165	144	129	84	
GZ12420 04	220	215	197	175	154	131	97	

gz12420-2p50-2-en\_a\_th

**DIMENSIONS AND WEIGHTS**

PUMP TYPE	RATED POWER	DIMENSIONS (mm)				WEIGHT
		A (4)	C (1)	M	T (2)	
	kW					kg (3)
GZ12420 03/2C-CP10W	110	2982	302	236	4602	531
GZ12420 03/2B-CP10W	130	3132	302	236	4752	577
GZ12420 03/3A-CP10W	150	3262	302	236	4882	617
GZ12420 03-CP10W	150	3262	302	236	4882	617
GZ12420 04/3B-CP12W	185	3254	306	276	4639	710
GZ12420 04/3A-CP12W	185	3254	306	276	4639	710
GZ12420 04-CP12W	220	3404	306	276	4789	774

gz12420-2p50-2-en\_a\_td

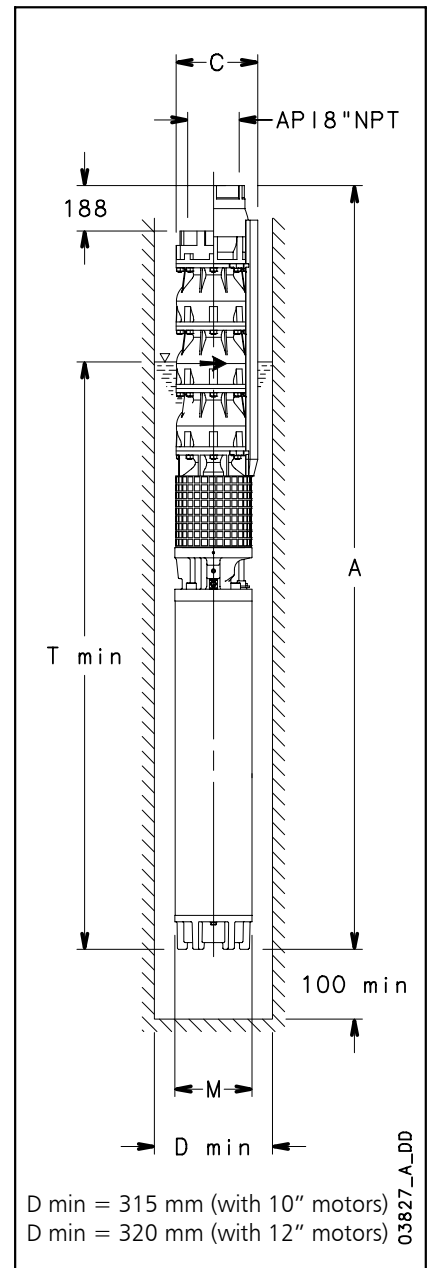

D min = 315 mm (with 10" motors)  
D min = 320 mm (with 12" motors)

03827\_A\_DD

- 1) Max electric pump diameter with 2 motor cables included.  
In case of 1 motor cable C = 293 mm with CP10W motor.  
C = 300 mm with CP12W motor.
- 2) T min valid only for max flow speed of 6,8 m/s between pump and perforation pipe.  
In case this velocity is exceeded, please contact our sales network.
- 3) Without cables.
- 4) For pumps without non-return valve, reduce dimension A by 188 mm, and reduce weight by 16,7 Kg.

**GZ12420 SERIES, 3 TO 4 STAGES  
OPERATING CHARACTERISTICS AT 50 Hz**

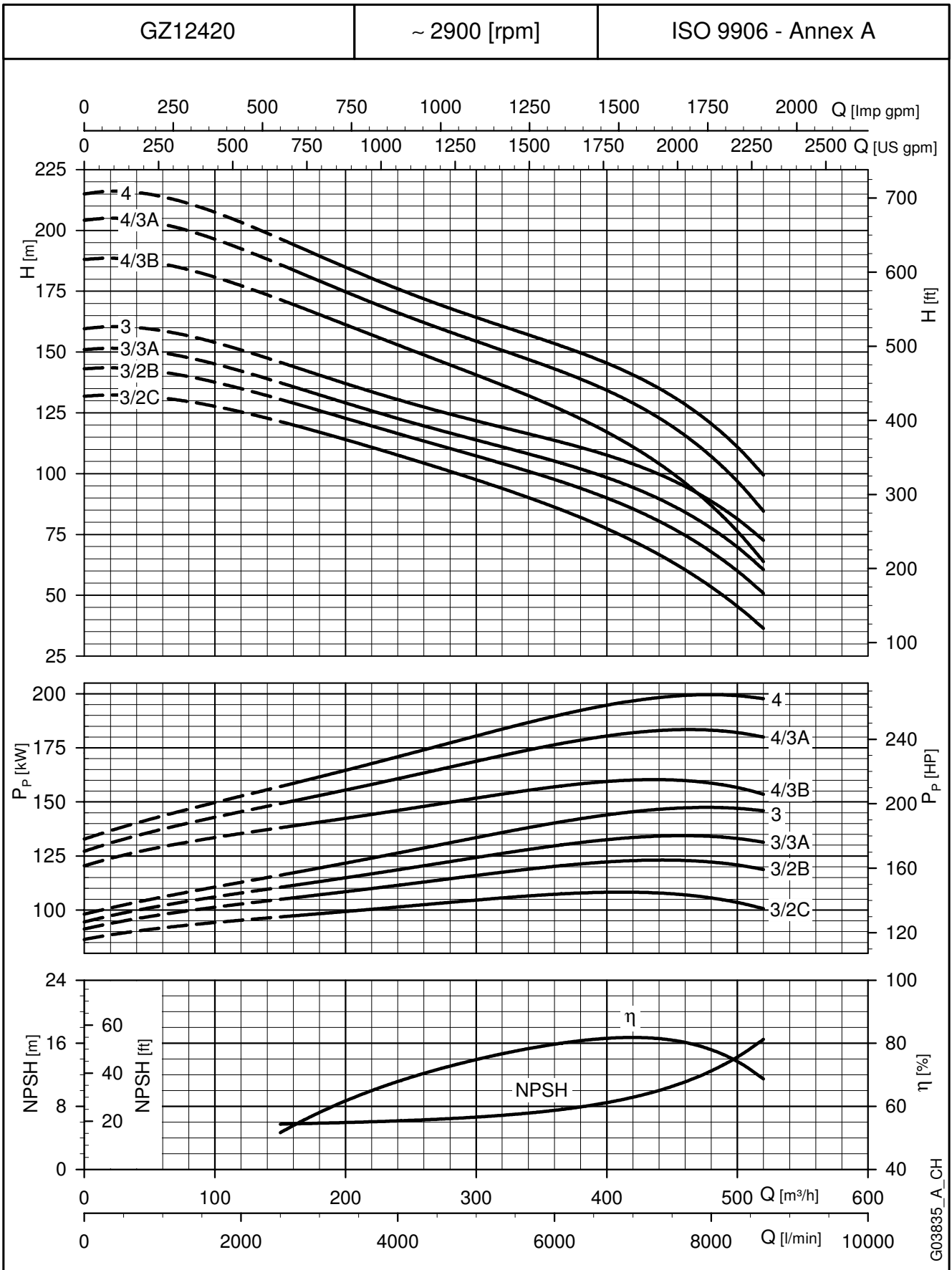

These performances are valid for liquids with density  $\rho = 1.0 \text{ Kg/dm}^3$  and kinematic viscosity  $\nu = 1 \text{ mm}^2/\text{sec}$ .

**GZ12420 SERIES, 5 TO 7 STAGES  
OPERATING CHARACTERISTICS AT 50 Hz**

PUMP TYPE	RATED POWER	Q = DELIVERY						
		l/min	0	2500	4167	5833	7000	8667
		m <sup>3</sup> /h	0	150	250	350	420	520
kW		H = TOTAL HEAD METRES COLUMN OF WATER						
GZ12420 05/2B	260	251	231	203	177	156	102	
GZ12420 05	260	268	246	218	191	174	121	
GZ12420 06/2B	300	305	280	247	215	191	128	
GZ12420 06	300	321	294	261	229	208	143	
GZ12420 07/2B	350	359	329	291	254	226	152	
GZ12420 07	350	375	344	306	268	244	169	

gz12420-2p50-3-en\_a\_th

**DIMENSIONS AND WEIGHTS**

PUMP TYPE	RATED POWER	DIMENSIONS (mm)				WEIGHT
		A (4)	C (1)	M	T (2)	
GZ12420 05/2B-CP12W	260	3789	306	276	4939	865
GZ12420 05-CP12W	260	3789	306	276	4939	865
GZ12420 06/2B-CP12W	300	4174	306	276	5089	958
GZ12420 06-CP12W	300	4174	306	276	5089	958
GZ12420 07/2B-**	350	-	-	-	-	-
GZ12420 07-**	350	-	-	-	-	-

\*\* For power above 350 kW please contact our sales network.

gz12420-2p50-3-en\_a\_td

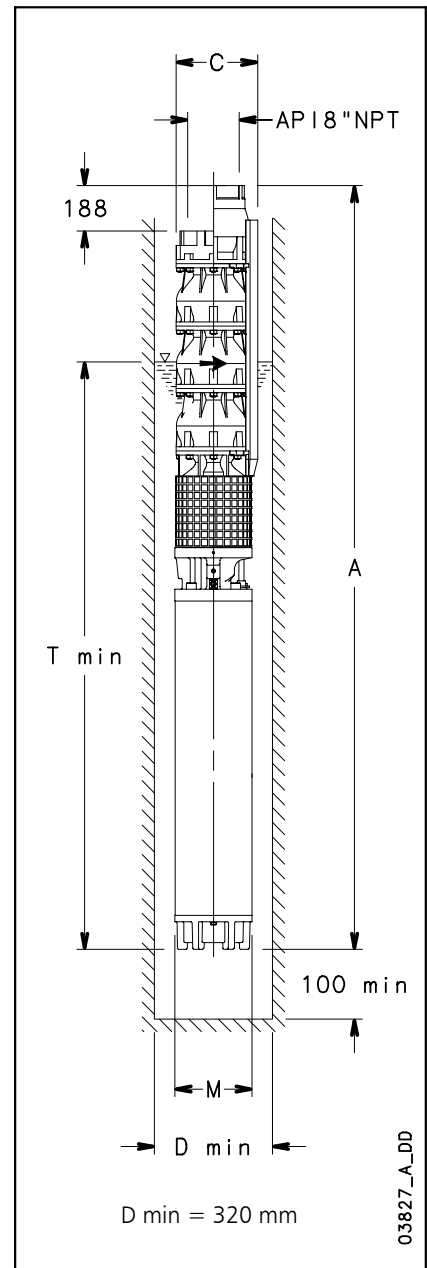

03827\_A\_DD

- 1) Max electric pump diameter with 2 motor cables included.  
In case of 1 motor cable C = 300 mm with CP12W motor.
- 2) T min valid only for max flow speed of 6,8 m/s between pump and perforation pipe.  
In case this velocity is exceeded, please contact our sales network.
- 3) Without cables.
- 4) For pumps without non-return valve, reduce dimension A by 188 mm, and reduce weight by 16,7 Kg.

**GZ12420 SERIES, 5 TO 7 STAGES  
OPERATING CHARACTERISTICS AT 50 Hz**

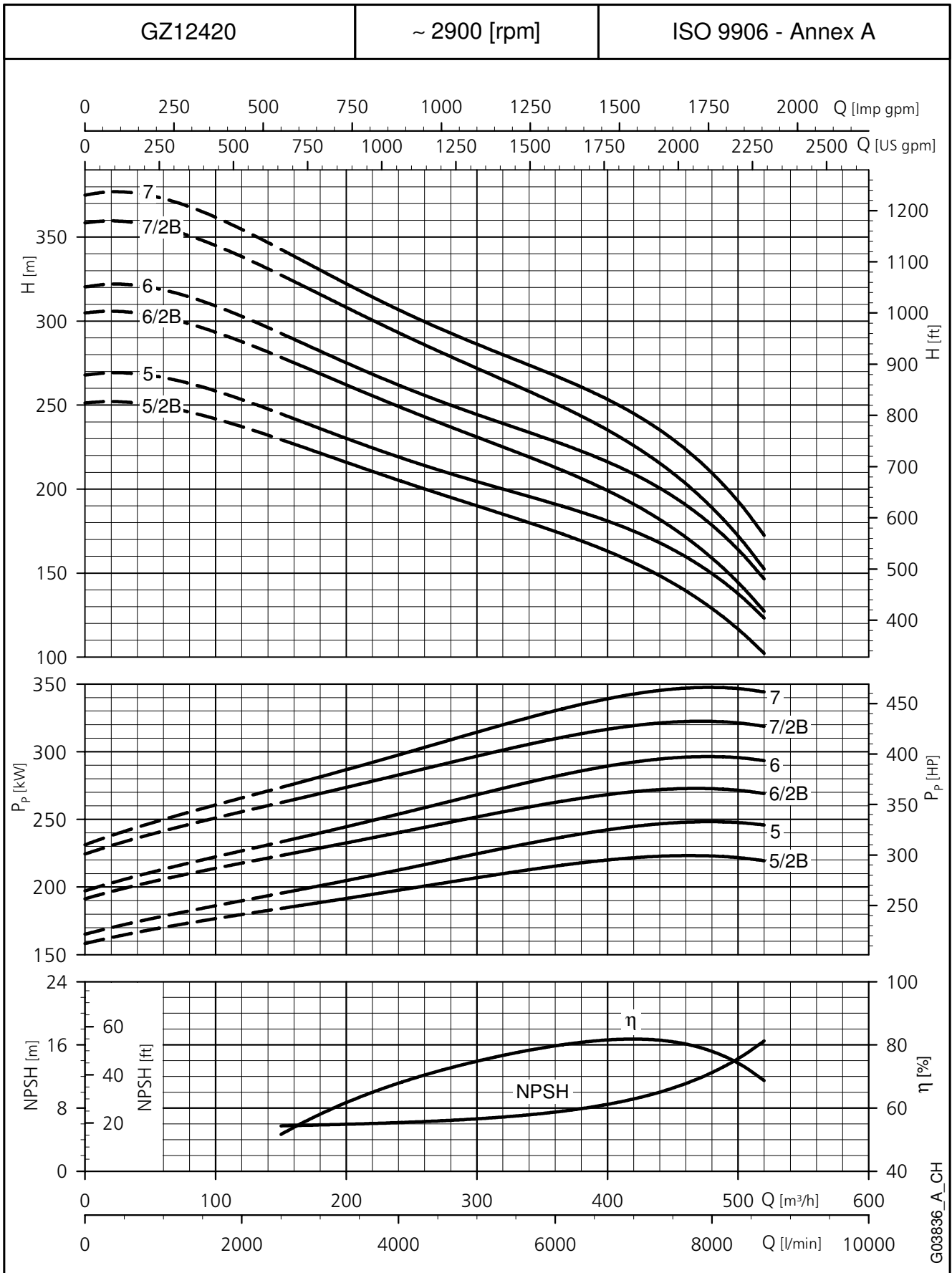

G03836\_A\_CH

These performances are valid for liquids with density  $\rho = 1.0 \text{ Kg/dm}^3$  and kinematic viscosity  $\nu = 1 \text{ mm}^2/\text{sec}$ .

## GZ12340 PUMP SERIES DIMENSIONS AND WEIGHTS

PUMP TYPE	MAX POWER ABSORBED BY PUMP kW	DIMENSIONS (mm)			WEIGHT kg <sup>(3)</sup>	Ø MIN. WELL mm
		L <sup>(4)</sup>	C <sup>(1)</sup>	U <sup>(2)</sup>		
GZ12340 01/1B-8	29,2	510	290	2900	72	305
GZ12340 01/1A-8	34,9	510	290	2900	72	305
GZ12340 01-8	42,6	510	290	2900	72	305
GZ12340 02/2C-8	50,5	745	290	2900	99,3	305
GZ12340 02/2B-8	57,2	745	290	2900	99,3	305
GZ12340 02/2A-8	70,5	745	290	2900	99,3	305
GZ12340 02-8	84,2	745	290	2900	99,3	305
GZ12340 03/2C-10	94,6	980	302	2900	129,4	315
GZ12340 03/3A-10	109,1	980	302	2900	129,4	315
GZ12340 03/1A-10	124,5	980	302	2900	129,4	315
GZ12340 03-10	132,4	980	302	2900	129,4	315
GZ12340 04/2B-10	147,4	1215	302	2900	156,7	315
GZ12340 04/2A-12	159,6	1215	302	2900	157,5	320
GZ12340 04-12	173,8	1215	302	2900	157,5	320
GZ12340 05/2B-12	193,3	1450	302	2900	184,8	320
GZ12340 05/2A-12	205,2	1450	302	2900	184,8	320
GZ12340 05-12	219,5	1450	302	2900	184,8	320
GZ12340 06/2B-12	235,2	1685	302	2900	212,1	320
GZ12340 06/2A-12	246,5	1685	302	2900	212,1	320
GZ12340 06-12	260,7	1685	302	2900	212,1	320
GZ12340 07/3A-12	280,0	1920	302	2900	239,4	320
GZ12340 07-12	301,0	1920	302	2900	239,4	320
GZ12340 08/3A-12	333,1	2155	302	2900	266,7	320
GZ12340 08-12	354,8	2155	302	2900	266,7	320

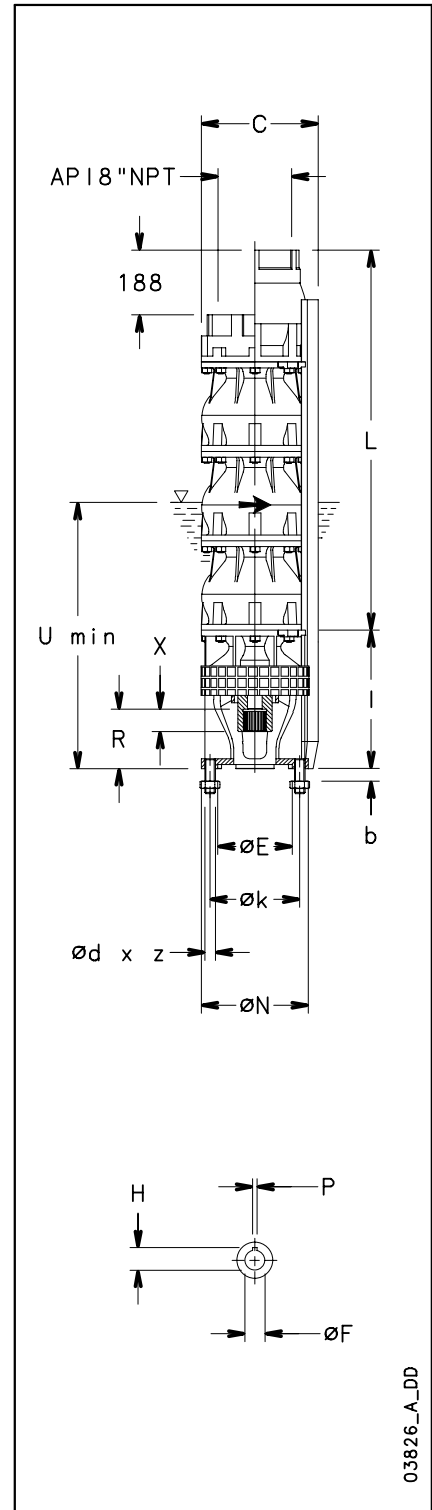

## MOTOR COUPLING

gz12340p-50-en\_b\_td

MOTOR CONNECTION	DIMENSIONS (mm)							
	N	k	d	z	b	E <sup>H7</sup>	R	I
8" (NEMA)	185	152,4	M16	4	20	127	101,45	240
10"	232	190,5	M20	4	22	127	101,45	300
12"	232	190,5	M20	4	23	127	126,85	300

COUPLING	DIMENSIONS (mm)			
	NUMBER OF TEETH	DIAMETRAL PITCH	PRESSURE ANGLE	X
8" (NEMA)	23	16/32	30°	38

COUPLING	DIMENSIONS (mm)			
	F	H	P	X
10"	42.85 <sup>h6</sup>	47,6	9,5	86
12"	49.212 <sup>h6</sup>	54,5	12,7	95

z12-mtcn-50-en\_a\_td

- 1) Max pump diameter with 2 motor cables included.
- 2) U min valid only for max flow speed of 6,8 m/s between pump and perforation pipe.
- 3) Weight with non-return valve. For pumps without non-return valve, reduce by 16,7 Kg.
- 4) For pumps without non-return valve, reduce dimension L by 188 mm.

## GZ12420 PUMP SERIES DIMENSIONS AND WEIGHTS

PUMP TYPE	MAX POWER ABSORBED BY PUMP kW	DIMENSIONS (mm)			WEIGHT kg <sup>(3)</sup>	Ø MIN. WELL mm
		L <sup>(4)</sup>	C <sup>(1)</sup>	U <sup>(2)</sup>		
GZ12420 01/1C-8	29,7	510	290	2900	72	305
GZ12420 01/1B-8	35,4	510	290	2900	72	305
GZ12420 01/1A-8	43,1	510	290	2900	72	305
GZ12420 01-8	47,0	510	290	2900	72	305
GZ12420 02/2C-8	58,2	745	290	2900	99,3	305
GZ12420 02/2B-8	71,5	745	290	2900	99,3	305
GZ12420 02/2A-8	86,2	745	290	2900	99,3	305
GZ12420 02-10	98,5	745	302	2900	102,1	315
GZ12420 03/2C-10	109,6	980	302	2900	129,4	315
GZ12420 03/2B-10	122,8	980	302	2900	129,4	315
GZ12420 03/3A-10	134,1	980	302	2900	129,4	315
GZ12420 03-10	147,8	980	302	2900	129,4	315
GZ12420 04/3B-12	161,3	1215	302	2900	157,5	320
GZ12420 04/3A-12	184,3	1215	302	2900	157,5	320
GZ12420 04-12	200,1	1215	302	2900	157,5	320
GZ12420 05/2B-12	223,1	1450	302	2900	184,8	320
GZ12420 05-12	247,6	1450	302	2900	184,8	320
GZ12420 06/2B-12	269,8	1685	302	2900	212,1	320
GZ12420 06-12	291,0	1685	302	2900	212,1	320
GZ12420 07/2B-12	325,4	1920	302	2900	239,4	320
GZ12420 07-12	350,2	1920	302	2900	239,4	320

gz12420p-50-en\_b\_td

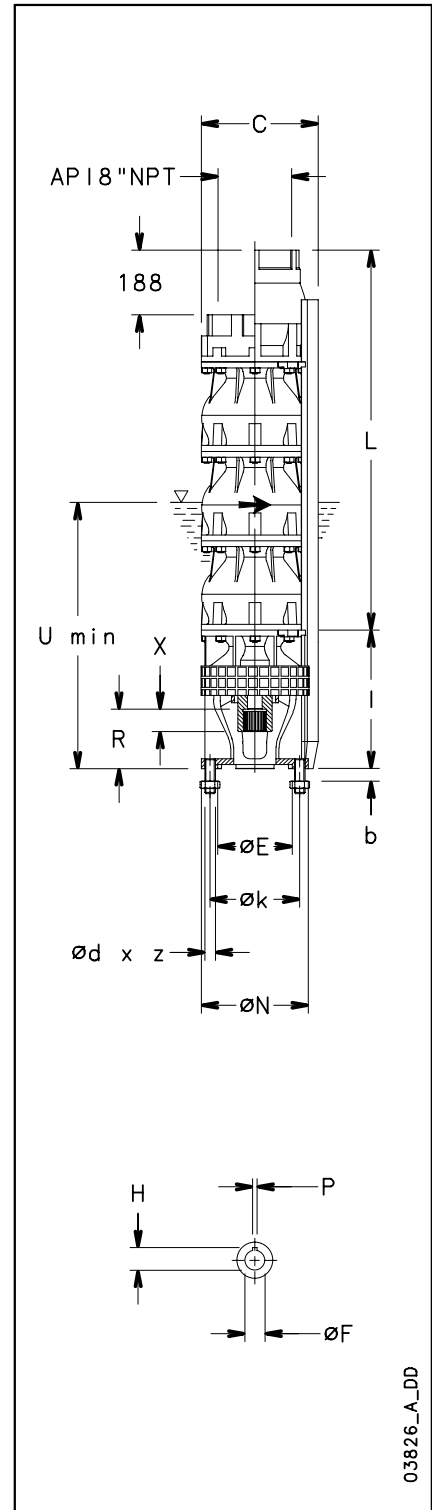

## MOTOR COUPLING

MOTOR CONNECTION	DIMENSIONS (mm)							
	N	k	d	z	b	E <sup>H7</sup>	R	I
8" (NEMA)	185	152,4	M16	4	20	127	101,45	240
10"	232	190,5	M20	4	22	127	101,45	300
12"	232	190,5	M20	4	23	127	126,85	300

COUPLING	DIMENSIONS (mm)			
	Profile of gear coupling according to NEMA			
	NUMBER OF TEETH	DIAMETRAL PITCH	PRESSURE ANGLE	X
8" (NEMA)	23	16/32	30°	38

  

COUPLING	DIMENSIONS (mm)			
	F	H	P	X
10"	42.85 <sup>h6</sup>	47,6	9,5	86
12"	49.212 <sup>h6</sup>	54,5	12,7	95

z12-mtcn-50-en\_a\_td

- 1) Max pump diameter with 2 motor cables included.
- 2) U min valid only for max flow speed of 6,8 m/s between pump and perforation pipe.
- 3) Weight with non-return valve. For pumps without non-return valve, reduce by 16,7 Kg.
- 4) For pumps without non-return valve, reduce dimension L by 188 mm.

**GZ12 SERIES  
PUMP CROSS SECTION AND LIST OF COMPONENTS**

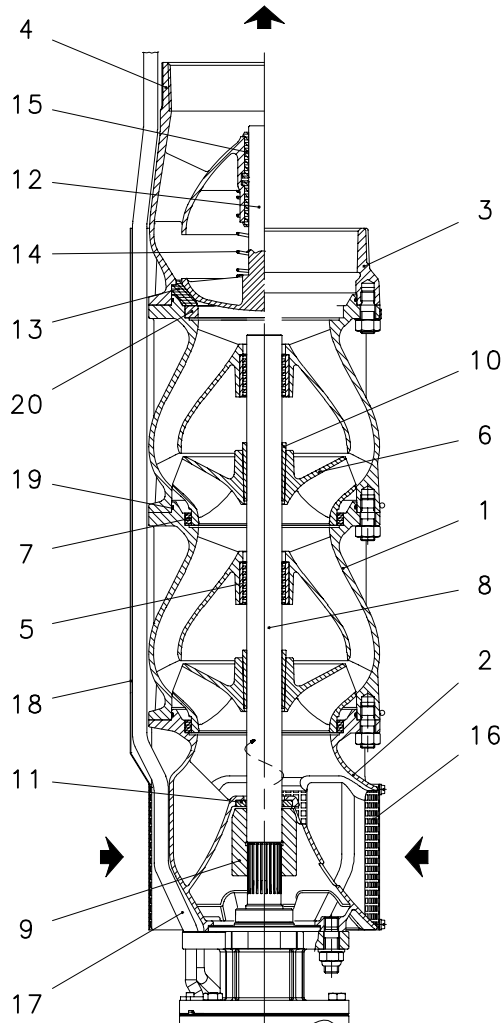

REF. N.	DESCRIPTION
1	Stage casing
2	Suction casing
3	Delivery casing
4	Valve body
5	Bearing bush
6	Impeller
7	Wear ring
8	Shaft
9	Coupling
10	Locking sleeve
11	Thrust bearing
12	Valve plate
13	Valve seat
14	Valve spring
15	Wing valve
16	Suction strainer
17	Cable
18	Cable protection
19	O-ring
20	Intermediate ring

z12-2p50-en\_a\_tp

MOT. CP8W  
( 8" NEMA )

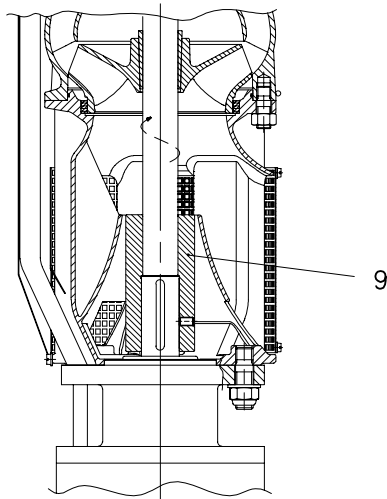

MOT. CP10W

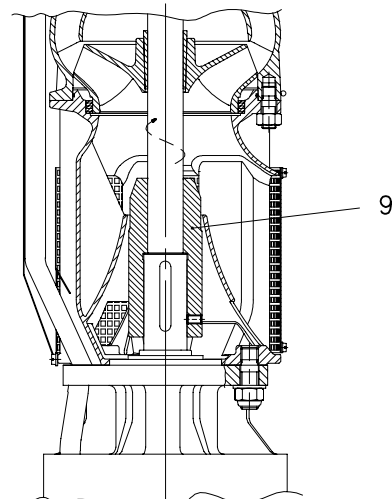

MOT. CP12W

G03821\_A\_DS



## 6" Submersible motors

### CP6W Series



Water filled submersible motors.

The robust design together with excellent choice of materials ensures optimal performance, ease of installation and reliability in all applications. For extremely demanding operation as high water temperature or aggressive environments special versions are available.

#### SPECIFICATIONS

- **Stainless steel** outer sleeve.
- Shaft extension and coupling dimensions to **NEMA** standards.
- **Rewindable stator.**
- Class **Y insulation.**
- Protection class: **IP68.**
- Compensating bellows for internal liquid expansion.
- Axial load supported by Kingsbury type thrust bearing.
- **Mechanical seal** protected by sand guard.
- Maximum **immersion depth:** 350 m.
- Maximum **number of starts per hour** at regular intervals: 15.
- Maximum supply **voltage variations** allowed :  $\pm 10\%$ .
- Maximum water **temperature:** 30°C.  
Max. temperature applies to motors working in a installation capable of delivering a flow of water around the motor jacket as following:  
Standard versions 0,2 m/s (4÷9,3 kW), 0,3 m/s (11÷30 kW) and 0,5 m/s (37 kW).  
HT versions 0,2 m/s (5,5÷7,5 kW), 0,3 m/s (9,3÷26 kW) and 0,5 m/s (30 kW).
- **Axial thrust:**  
16000 N from 4 to 22 kW;  
30000 N from 26 to 37 kW.
- **Power supply** cable suitable for drinkable water.
- **Versions:**  
- Three-phase:  
4 to 37 kW 380-415 V, 50 Hz.
- **Horizontal operation:**  
valid for all versions provided that the direction of the axial thrust generated by the impellers is always from the pump to the motor.
- Flat power supply cable.
- Screws included.

#### SPECIAL VERSIONS

- Motors with double cable outlet for star/delta start.
- **CP6WN series:** complete range available realized of AISI 316 stainless steel.
- **CP6WR series:** complete range available realized of Duplex stainless steel.
- **HT series:** complete range available for all the CP6W/N/R construction, realized for applications in high temperature environments (**up to 60°C**) or under inverter.

#### OPTIONAL FEATURES

- Silicon Carbide mechanical seal.
- Special voltages.

#### ACCESSORIES

- Temperature sensor **PT 100 / PTC.**

**Rewindable stator**

**Thrust bearing Kingsbury type**

**Mechanical seal**

**CP6W - CP6WN - CP6WR MOTOR SERIES  
MOTOR CROSS SECTION**

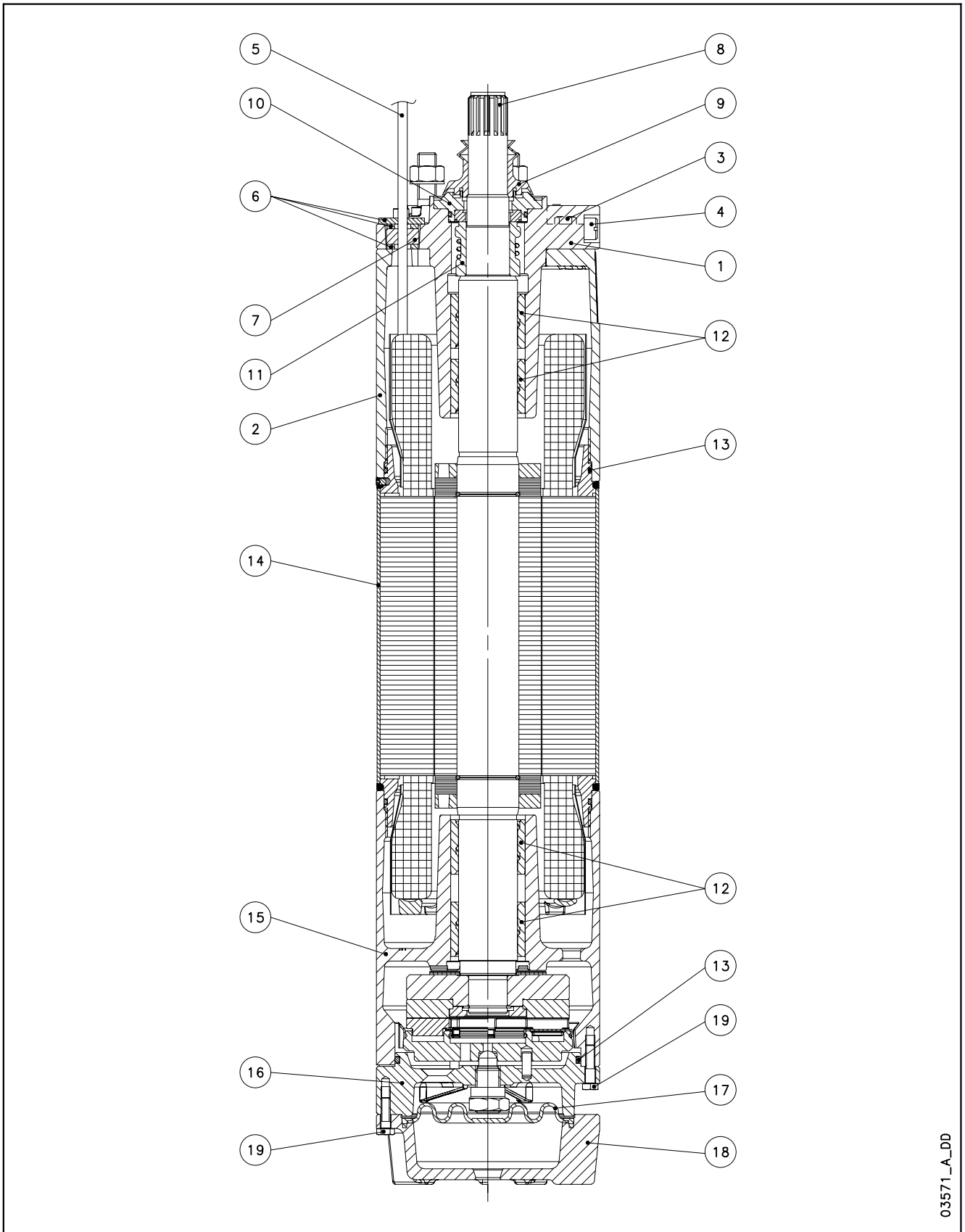

03571\_A\_DD

## CP6W TABLE OF MATERIALS

REF. N°	PART	MATERIAL	DESIGNATION	
			EUROPE	USA
1	Upper bracket	Cast iron	EN-GJL-200	Class 25 B
2	Spacer	Cast iron	EN-GJL-200	Class 25 B
3	Filling plug + OR	Stainless steel+NBR	EN 10088-1-X5CrNiMo17-12-2 (1.4401)	AISI 316
4	Vent valve	Stainless steel	EN 10088-1-X5CrNiMo17-12-2 (1.4401)	AISI 316
5	Cable	EPR		
6	Cable gland plate	Stainless steel	EN 10088-1-X5CrNi18-10 (1.4301)	AISI304
7	Cable gland	EPDM		
8	Shaft end	Stainless steel	EN 10088-1-X20Cr13 (1.4021)	AISI420
9	Removable sand guard	EPDM		
10	Mechanical seal cover	Stainless steel	EN 10213-4-GX5CrNi19-10 (1.4308)	ASTM CF-8 (AISI 304 cast)
11	Mechanical seal	Carbon graphite / Aluminium oxide		
12	Bush bearings	Carbon graphite		
13	Elastomers	NBR		
14	Motor sleeve	Stainless steel	EN 10088-1-X2CrNi19-11 (1.4306)	AISI304L
15	Lower bracket	Cast iron	EN-GJL-200	Class 25 B
16	Thrust bearing bracket	Cast iron	EN-GJL-200	Class 25 B
17	Diaphragm	EPDM		
18	Lower cover	Cast iron	EN-GJL-200	Class 25 B
19	Bolts and screws	Stainless steel	EN 10088-1-X5CrNi18-10 (1.4301)	AISI304
	Cooling liquid	Water + antifreeze		

## CP6WN TABLE OF MATERIALS

L6w-2p50-en\_b\_tm

REF. N°	PART	MATERIAL	DESIGNATION	
			EUROPE	USA
1	Upper bracket	Stainless steel	EN 10213-4-GX5CrNiMo19-11-2 (1.4408)	ASTM CF-8M (AISI 316 cast)
2	Spacer	Stainless steel	EN 10213-4-GX5CrNiMo19-11-2 (1.4408)	ASTM CF-8M (AISI 316 cast)
3	Filling plug + OR	Stainless steel+NBR	EN 10088-1-X5CrNiMo17-12-2 (1.4401)	AISI 316
4	Vent valve	Stainless steel	EN 10088-1-X5CrNiMo17-12-2 (1.4401)	AISI 316
5	Cable	EPR		
6	Cable gland plate	Stainless steel	EN 10088-1-X5CrNiMo17-12-2 (1.4401)	AISI 316
7	Cable seal	EPDM		
8	Shaft end	Duplex stainless steel	EN 10088-1-X2CrNiMoN22-5-3 (1.4462)	A276/A790-S31803
9	Removable sand guard	EPDM		
10	Mechanical seal cover	Stainless steel	EN 10213-4-GX5CrNiMo19-11-2 (1.4408)	ASTM CF-8M (AISI 316 cast)
11	Mechanical seal	Carbon graphite / Aluminium oxide		
12	Bush bearings	Carbon graphite		
13	Elastomers	NBR		
14	Motor sleeve	Stainless steel	EN 10088-1-X2CrNiMo17-12-2 (1.4404)	AISI 316L
15	Lower bracket	Stainless steel	EN 10213-4-GX5CrNiMo19-11-2 (1.4408)	ASTM CF-8M (AISI 316 cast)
16	Thrust bearing bracket	Stainless steel	EN 10213-4-GX5CrNiMo19-11-2 (1.4408)	ASTM CF-8M (AISI 316 cast)
17	Diaphragm	EPDM		
18	Lower cover	Stainless steel	EN 10213-4-GX5CrNiMo19-11-2 (1.4408)	ASTM CF-8M (AISI 316 cast)
19	Bolts and screws	Stainless steel	EN 10088-1-X5CrNiMo17-12-2 (1.4401)	AISI 316
	Cooling liquid	Water + antifreeze		

## CP6WR TABLE OF MATERIALS

L6wn-2p50-en\_b\_tm

REF. N°	PART	MATERIALE	DESIGNATION	
			EUROPE	USA
1	Upper bracket	Duplex stainless steel	EN 10213-4-GX2CrNiMoCuN25-6-3-3 (1.4517)	
2	Spacer	Duplex stainless steel	EN 10213-4-GX2CrNiMoCuN25-6-3-3 (1.4517)	
3	Filling plug + OR	Duplex s. s.+NBR	EN 10088-1-X2CrNiMoN22-5-3 (1.4462)	A276/A790-S31803
4	Vent valve	Duplex stainless steel	EN 10088-1-X2CrNiMoN22-5-3 (1.4462)	A276/A790-S31803
5	Cable	EPR		
6	Cable gland plate	Stainless steel	EN 10088-1X1NiCrMoCu25-20-5 (1.4539)	AISI 904L
7	Cable gland	EPDM		
8	Shaft end	Duplex stainless steel	EN 10088-1-X2CrNiMoN22-5-3 (1.4462)	A276/A790-S31803
9	Removable sand guard	EPDM		
10	Mechanical seal cover	Duplex stainless steel	EN 10088-1-X2CrNiMoN22-5-3 (1.4462)	A276/A790-S31803
11	Mechanical seal	Carbon graphite / Aluminium oxide		
12	Bush bearings	Carbon graphite		
13	Elastomers	NBR		
14	Motor sleeve	Stainless steel	EN 10088-1X1NiCrMoCu25-20-5 (1.4539)	AISI 904L
15	Lower bracket	Duplex stainless steel	EN 10213-4-GX2CrNiMoCuN25-6-3-3 (1.4517)	
16	Thrust bearing bracket	Duplex stainless steel	EN 10213-4-GX2CrNiMoCuN25-6-3-3 (1.4517)	
17	Diaphragm	EPDM		
18	Lower cover	Duplex stainless steel	EN 10213-4-GX2CrNiMoCuN25-6-3-3 (1.4517)	
19	Bolts and screws	Duplex stainless steel	EN 10088-1-X2CrNiMoN22-5-3 (1.4462)	A276/A790-S31803
	Cooling liquid	Water + antifreeze		

L6wr-2p50-en\_b\_tm

## CP6W MOTOR SERIES IDENTIFICATION CODE

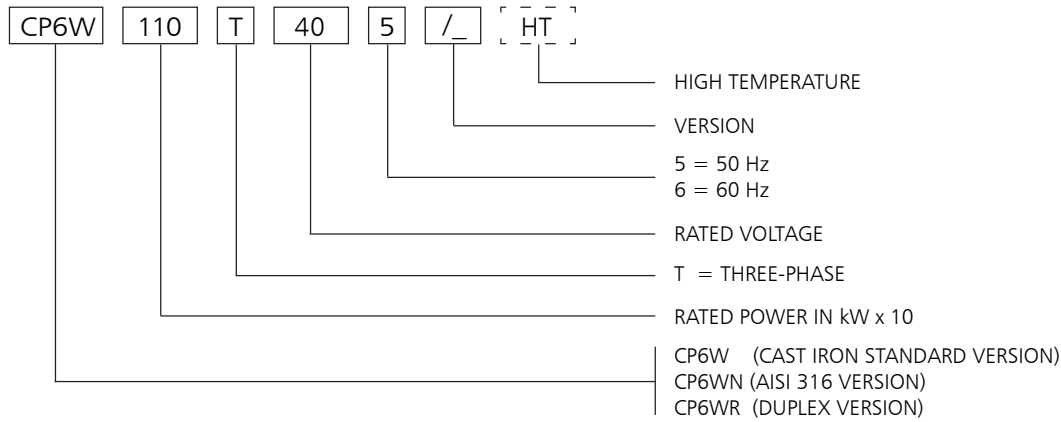

EXAMPLE : CP6W110T405/A HT

CP6W MOTOR :  
RATED POWER 11 kW; THREE-PHASE;  
RATED VOLTAGE 400 V; 50 Hz; /A VERSION; HIGH TEMPERATURE

## RATING PLATE

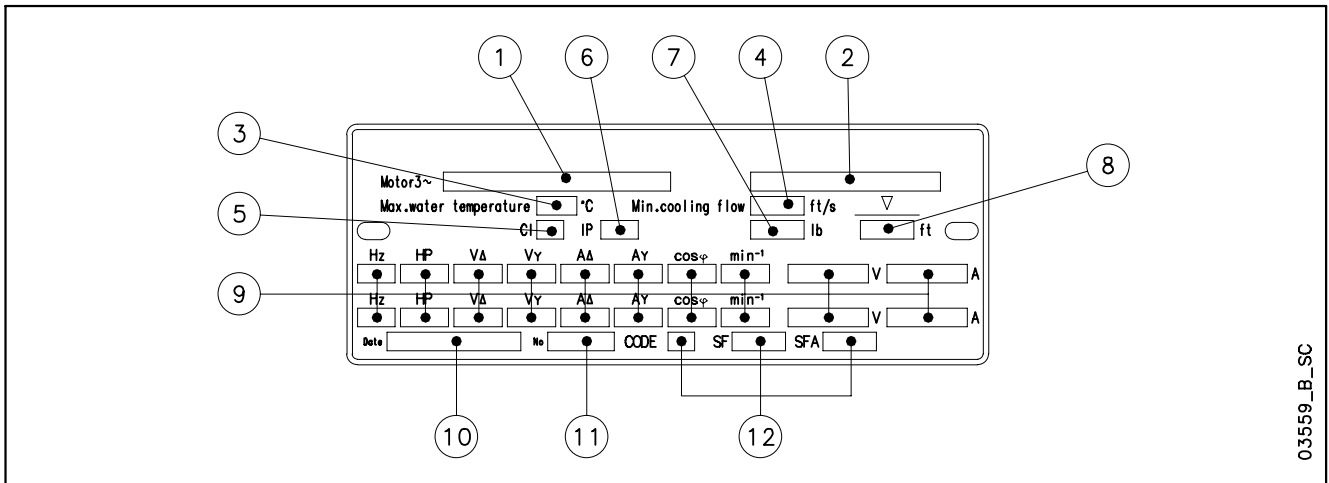

03559\_B\_SC

## LEGEND

- 1 - Motor type
- 2 - Code
- 3 - Maximum water temperature
- 4 - Minimum water velocity
- 5 - Insulation class
- 6 - Protection class
- 7 - Weight
- 8 - Maximum immersion depth
- 9 - Operating characteristics
- 10 - Production date
- 11 - Serial number
- 12 - Characteristics at service factor

**CP6W MOTOR SERIES  
DIMENSIONS AND WEIGHTS AT 50 Hz**

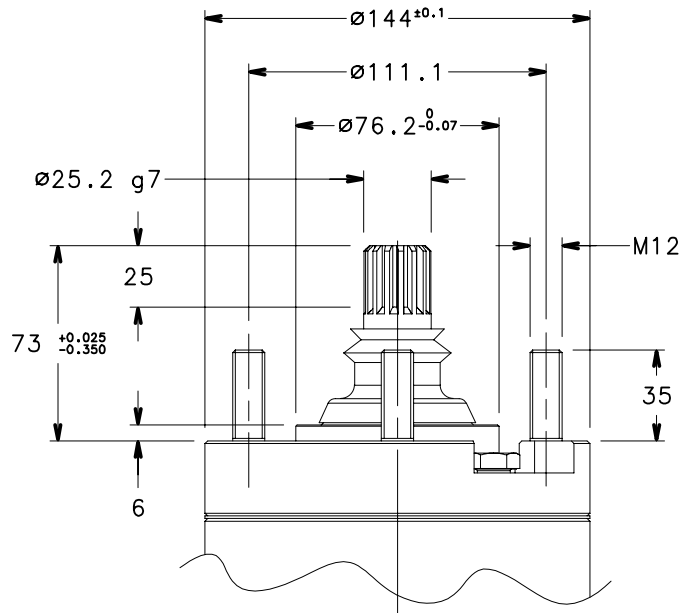
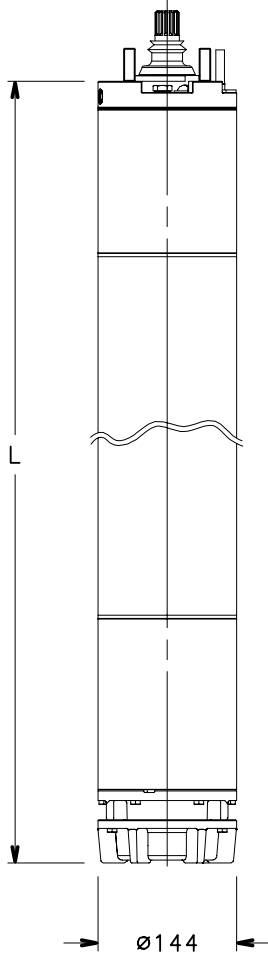

MOTOR TYPE	RATED POWER		DIMENSIONS (mm) L	WEIGHT kg
	kW	HP		
CP6W40T405	4	5,5	583	38
CP6W55T405	5,5	7,5	613	42
CP6W75T405	7,5	10	653	46
CP6W93T405	9,3	12,5	683	50
CP6W110T405	11	15	723	54
CP6W130T405	13	17,5	763	58
CP6W150T405	15	20	833	66
CP6W185T405	18,5	25	903	74
CP6W220T405	22	30	943	77
CP6W260T405	26	35	1071	86
CP6W300T405	30	40	1151	94
CP6W370T405	37	50	1301	108

cp6w-2p50-en\_b\_td

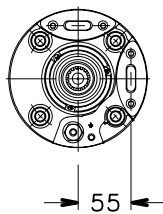

MOTOR TYPE	RATED POWER		DIMENSIONS (mm) L	WEIGHT kg
	kW	HP		
CP6W40T405 HT	4	5,5	613	42
CP6W55T405 HT	5,5	7,5	653	46
CP6W75T405 HT	7,5	10	683	50
CP6W93T405 HT	9,3	12,5	723	54
CP6W110T405 HT	11	15	763	58
CP6W130T405 HT	13	17,5	833	66
CP6W150T405 HT	15	20	903	74
CP6W185T405 HT	18,5	25	943	77
CP6W220T405 HT	22	30	1071	86
CP6W260T405 HT	26	35	1151	94
CP6W300T405 HT	30	40	1301	108

cp6w-ht-2p50-en\_a\_td

03570\_D\_DD

## CP6W MOTOR SERIES THREE-PHASE OPERATING CHARACTERISTICS AT 50 Hz

MOTOR TYPE	RATED POWER		RATED VOLTAGE	OPERATING CHARACTERISTICS AT RATED POWER				DIRECT START		MAX WATER TEMPERATURE	CABLE TYPE		
	THREE-PHASE	kW		HP	RATED CURRENT	rpm	$\eta$ %	$\cos\phi$	Ts/Tn*		Is/In	°C	Sec. (mm <sup>2</sup> )
			V	A							DOL	Y/D	L (m)
CP6W40T405	4	5,5	380	9,89	2835	68,1	0,9	1,00	3,56	30	4	-	4
			400	9,26	2865	71,0	0,88	1,13	4,00				
			415	9,13	2880	71,5	0,85	1,21	4,20				
CP6W55T405	5,5	7,5	380	12,7	2855	75,4	0,88	1,18	4,37	30	4	4	4
			400	12,4	2875	75,7	0,85	1,31	4,70				
			415	12,5	2885	75,4	0,82	1,42	4,85				
CP6W75T405	7,5	10	380	17,0	2840	74,9	0,9	1,26	4,34	30	4	4	4
			400	16,4	2860	76,0	0,87	1,41	4,74				
			415	16,2	2875	76,5	0,84	1,52	4,96				
CP6W93T405	9,3	12,5	380	20,5	2840	77,6	0,89	1,51	4,64	30	4	4	4
			400	20,0	2860	78,2	0,86	1,68	5,01				
			415	19,9	2870	78,3	0,83	1,81	5,21				
CP6W110T405	11	15	380	24,2	2830	77,2	0,9	1,44	4,38	30	4	4	4
			400	23,5	2850	78,0	0,87	1,47	4,75				
			415	23,4	2865	78,0	0,84	1,73	4,94				
CP6W130T405	13	17,5	380	28,1	2830	77,9	0,9	1,31	4,53	30	4	4	4
			400	27,1	2855	78,9	0,88	1,47	4,93				
			415	27,0	2865	79,1	0,9	1,59	5,15				
CP6W150T405	15	20	380	32,1	2830	80,2	0,88	1,55	4,88	30	4	4	4
			400	31,5	2855	80,6	0,85	1,72	5,25				
			415	31,3	2865	80,9	0,82	1,86	5,46				
CP6W185T405	18,5	25	380	38,5	2845	81,8	0,89	1,77	5,23	30	6	4	4
			400	37,6	2860	82,4	0,86	1,97	5,65				
			415	37,5	2870	82,4	0,83	2,13	5,86				
CP6W220T405	22	30	380	47,3	2865	81,7	0,87	0,86	4,60	30	6	4	4
			400	46,5	2880	82,2	0,83	0,96	4,93				
			415	46,7	2890	82,2	0,8	1,04	5,09				
CP6W260T405	26	35	380	56,5	2860	81,9	0,85	1,58	4,82	30	6	4	4
			400	55,4	2880	82,7	0,82	1,76	5,18				
			415	55,7	2890	82,7	0,79	1,90	5,35				
CP6W300T405	30	40	380	63,8	2870	82,3	0,87	1,07	4,94	30	10	4	4
			400	62,3	2890	83,1	0,84	1,19	5,32				
			415	62,0	2900	83,3	0,81	1,29	5,55				
CP6W370T405	37	50	380	81,8	2845	79,6	0,86	1,03	4,25	30	10	4	4
			400	79,1	2870	81,2	0,83	1,15	4,63				
			415	79,4	2880	80,8	0,80	1,25	4,79				

\* Ts/Tn = ratio between starting torque and nominal torque.

cp6w-2p50-en\_f\_te

## CP6W HT MOTOR SERIES THREE-PHASE OPERATING CHARACTERISTICS AT 50 Hz

MOTOR TYPE	RATED POWER		RATED VOLTAGE	OPERATING CHARACTERISTICS AT RATED POWER						DIRECT START	MAX WATER TEMPERATURE	CABLE TYPE				
	THREE-PHASE	kW		HP	RATED CURRENT	rpm	$\eta$ %	cos $\phi$	Ts/Tn*			Is/In	°C	Sec. (mm <sup>2</sup> )		
														DOL	Y/D	L (m)
CP6W40T405 HT	4	5,5	380	9,81	2905	76,9	0,81	1,65	5,65	45	4	4	4			
			400	10,1	2915	75,5	0,76	1,83	5,78							
			415	10,5	2920	74,2	0,72	1,98	5,77							
CP6W55T405 HT	5,5	7,5	380	12,9	2895	77,1	0,84	1,75	5,71	45	4	4	4			
			400	13,0	2905	77,0	0,79	1,95	5,96							
			415	13,4	2915	76,3	0,75	2,10	6,03							
CP6W75T405 HT	7,5	10	380	16,9	2880	79,2	0,85	1,89	5,64	45	4	4	4			
			400	16,9	2890	79,0	0,81	2,11	5,91							
			415	17,3	2900	78,3	0,77	2,27	6,00							
CP6W93T405 HT	9,3	12,5	380	20,6	2865	79,2	0,87	1,72	5,13	45	4	4	4			
			400	20,4	2880	79,3	0,83	1,82	5,44							
			415	20,8	2890	78,4	0,79	2,07	5,53							
CP6W110T405 HT	11	15	380	23,8	2870	80,1	0,88	1,57	5,35	45	4	4	4			
			400	23,6	2885	80,1	0,84	1,75	5,69							
			415	23,9	2890	79,8	0,80	1,89	5,83							
CP6W130T405 HT	13	17,5	380	28,3	2860	81,8	0,85	1,80	5,55	45	4	4	4			
			400	28,1	2875	81,4	0,82	2,01	5,87							
			415	28,4	2885	81,4	0,78	2,17	6,03							
CP6W150T405 HT	15	20	380	31,8	2880	83,6	0,86	2,21	6,33	45	6	4	4			
			400	31,9	2890	83,4	0,82	2,46	6,65							
			415	32,5	2900	82,8	0,78	2,65	6,77							
CP6W185T405 HT	18,5	25	380	40,3	2895	83,9	0,83	1,04	5,40	45	6	4	4			
			400	40,5	2905	83,5	0,79	1,15	5,65							
			415	41,6	2910	83,0	0,75	1,24	5,71							
CP6W220T405 HT	22	30	380	48,5	2890	83,6	0,82	1,89	5,62	45	6	4	4			
			400	48,6	2905	83,6	0,78	2,10	5,90							
			415	49,7	2910	83,2	0,74	2,26	5,99							
CP6W260T405 HT	26	35	380	55,7	2895	83,8	0,85	1,24	5,66	45	10	4	4			
			400	55,2	2905	84,0	0,81	1,38	6,00							
			415	55,8	2915	83,9	0,77	1,49	6,17							
CP6W300T405 HT	30	40	380	67,1	2885	82,2	0,83	1,29	5,18	45	10	4	4			
			400	67,1	2900	82,8	0,78	1,44	5,46							
			415	68,8	2910	81,8	0,74	1,55	5,52							

\* Ts/Tn = ratio between starting torque and nominal torque.

cp6w-ht-2p50-en\_c\_te





## 8" Submersible motors

### CP8W Series



**Rewindable stator**

**Thrust bearing Kingsbury type**

**Mechanical seal**

Water filled submersible motors.

The robust design together with excellent choice of materials ensures optimal performance, ease of installation and reliability in all applications. For extremely demanding operation as high water temperature or aggressive environments special versions are available.

#### **SPECIFICATIONS**

- **Stainless steel** outer sleeve.
- Shaft extension and coupling dimensions to **NEMA** standards.
- **Rewindable stator.**
- Class **Y insulation.**
- Protection class: **IP68.**
- Compensating bellows for internal liquid expansion.
- Axial load supported by Kingsbury type thrust bearing.
- **Mechanical seal** protected by sand guard.
- Maximum **immersion depth:** 350 m.
- Maximum **number of starts per hour** at regular intervals: 10.
- Maximum supply **voltage variations** allowed :  $\pm 10\%$ .
- Maximum water **temperature:** 30°C.  
Max. temperature applies to motors working in a installation capable of delivering a flow of water around the motor jacket of at least 0,5 m/s.
- **Axial thrust:** 50000 N from 30 to 93 kW.
- **Power supply** cable suitable for drinkable water.
- **Versions:**
  - Three-phase: 30 to 93 kW 380-415 V, 50 Hz.
- **Horizontal operation:** valid for all versions provided that the direction of the axial thrust generated by the impellers is always from the pump to the motor.

#### **SPECIAL VERSIONS**

- Motors with double cable outlet for star/delta start.
- **CP8WN series:** complete range available realized of AISI 316 stainless steel.
- **CP8WR series:** complete range available realized of Duplex stainless steel.
- **HT series:** complete range available for all the CP8W/N/R construction, realized for applications in high temperature environments (**up to 60°C**) or under inverter.

#### **OPTIONAL FEATURES**

- Silicon Carbide mechanical seal.
- Special voltages.

#### **ACCESSORIES**

- Temperature sensor **PT 100 / PTC.**

**CP8W - CP8WN - CP8WR MOTOR SERIES  
MOTOR CROSS SECTION**

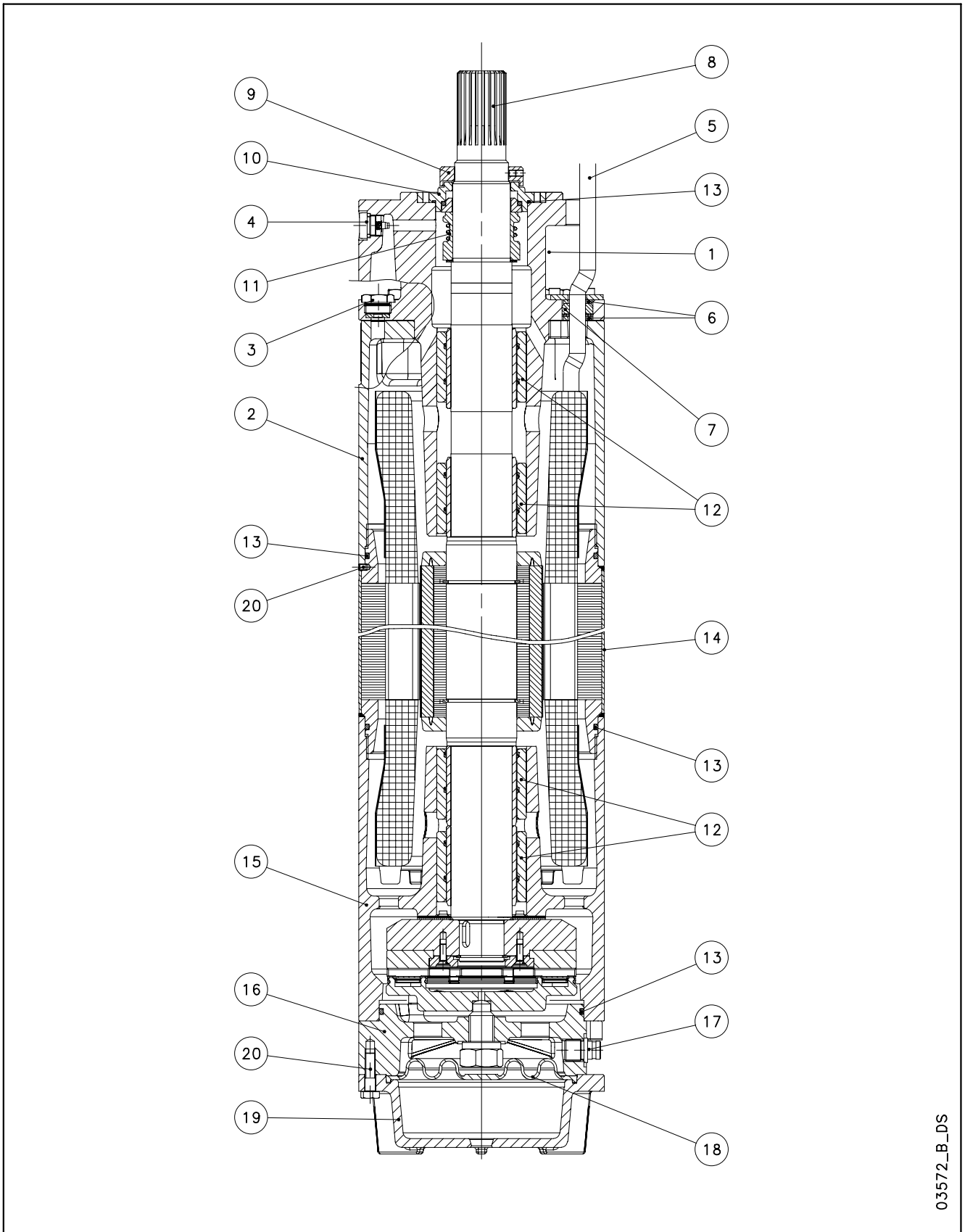

03572\_B\_DS

## CP8W TABLE OF MATERIALS

REF. N°	PART	MATERIAL	DESIGNATION	
			EUROPE	USA
1	Upper bracket	Cast iron	EN-GJL-200	Class 25 B
2	Spacer	Cast iron	EN-GJL-200	Class 25 B
3	Filling plug + OR	Stainless steel+NBR	EN 10088-1-X5CrNiMo17-12-2 (1.4401)	AISI 316
4	Vent valve	Stainless steel	EN 10088-1-X5CrNiMo17-12-2 (1.4401)	AISI 316
5	Cable	EPR		
6	Cable gland plate	Stainless steel	EN 10088-1-X5CrNi18-10 (1.4301)	AISI304
7	Cable gland	EPDM		
8	Shaft end	Duplex stainless steel	EN 10088-1-X2CrNiMoN22-5-3 (1.4462)	A276/A790-S31803
9	Removable sand guard	Stainless steel	EN 10088-1-X2CrNiMo17-12-2 (1.4404)	AISI 316L
10	Mechanical seal cover	Stainless steel	EN 10088-1-X2CrNiMo17-12-2 (1.4404)	AISI 316L
11	Mechanical seal	Carbon graphite / Aluminium oxide		
12	Bush bearings	Carbon graphite		
13	Elastomers	NBR		
14	Motor sleeve	Stainless steel	EN 10088-1-X2CrNi19-11 (1.4306)	AISI304L
15	Lower bracket	Cast iron	EN-GJL-200	Class 25 B
16	Thrust bearing bracket	Cast iron	EN-GJL-200	Class 25 B
17	Filling valve	Stainless steel	EN 10088-1-X5CrNiMo17-12-2 (1.4401)	AISI 316
18	Diaphragm	EPDM		
19	Lower cover	Cast iron	EN-GJL-200	Class 25 B
20	Bolts and screws	Stainless steel	EN 10088-1-X5CrNi18-10 (1.4301)	AISI304
	Cooling liquid	Water + antifreeze		

L8w-2p50-en\_a\_tm

## CP8WN TABLE OF MATERIALS

REF. N°	PART	MATERIAL	DESIGNATION	
			EUROPE	USA
1	Upper bracket	Stainless steel	EN 10213-4 - GX5CrNiMo19-11-2 (1.4408)	ASTM CF-8M (AISI 316 cast)
2	Spacer	Stainless steel	EN 10213-4 - GX5CrNiMo19-11-2 (1.4408)	ASTM CF-8M (AISI 316 cast)
3	Filling plug + OR	Stainless steel+NBR	EN 10088-1-X5CrNiMo17-12-2 (1.4401)	AISI 316
4	Vent valve	Stainless steel	EN 10088-1-X5CrNiMo17-12-2 (1.4401)	AISI 316
5	Cable	EPR		
6	Cable gland plate	Stainless steel	EN 10088-1-X5CrNiMo17-12-2 (1.4401)	AISI 316
7	Cable gland	EPDM		
8	Shaft end	Duplex stainless steel	EN 10088-1-X2CrNiMoN22-5-3 (1.4462)	A276/A790-S31803
9	Removable sand guard	Stainless steel	EN 10088-1-X2CrNiMo17-12-2 (1.4404)	AISI 316L
10	Mechanical seal cover	Stainless steel	EN 10088-1-X2CrNiMo17-12-2 (1.4404)	AISI 316L
11	Mechanical seal	Carbon graphite / Aluminium oxide		
12	Bush bearings	Carbon graphite		
13	Elastomers	NBR		
14	Motor sleeve	Stainless steel	EN 10088-1-X2CrNiMo17-12-2 (1.4404)	AISI 316L
15	Lower bracket	Stainless steel	EN 10213-4 - GX5CrNiMo19-11-2 (1.4408)	ASTM CF-8M (AISI 316 cast)
16	Thrust bearing bracket	Stainless steel	EN 10213-4 - GX5CrNiMo19-11-2 (1.4408)	ASTM CF-8M (AISI 316 cast)
17	Filling valve	Stainless steel	EN 10088-1-X5CrNiMo17-12-2 (1.4401)	AISI 316
18	Diaphragm	EPDM		
19	Lower cover	Stainless steel	EN 10213-4 - GX5CrNiMo19-11-2 (1.4408)	ASTM CF-8M (AISI 316 cast)
20	Bolts and screws	Stainless steel	EN 10088-1-X5CrNiMo17-12-2 (1.4401)	AISI 316
	Cooling liquid	Water + antifreeze		

L8wn-2p50-en\_a\_tm

## CP8WR TABLE OF MATERIALS

REF. N°	PART	MATERIAL	DESIGNATION	
			EUROPE	USA
1	Upper bracket	Duplex stainless steel	EN 10213-4-GX2CrNiMoCuN25-6-3-3 (1.4517)	
2	Spacer	Duplex stainless steel	EN 10213-4-GX2CrNiMoCuN25-6-3-3 (1.4517)	
3	Filling plug + OR	Duplex s. s.+NBR	EN 10088-1-X2CrNiMoN22-5-3 (1.4462)	A276/A790-S31803
4	Vent valve	Duplex stainless steel	EN 10088-1-X2CrNiMoN22-5-3 (1.4462)	A276/A790-S31803
5	Cable	EPR		
6	Cable gland plate	Stainless steel	EN 10088-1X1NiCrMoCu25-20-5 (1.4539)	AISI 904L
7	Cable gland	EPDM		
8	Shaft end	Duplex stainless steel	EN 10088-1-X2CrNiMoN22-5-3 (1.4462)	A276/A790-S31803
9	Removable sand guard	Duplex stainless steel	EN 10088-1-X2CrNiMoN22-5-3 (1.4462)	A276/A790-S31803
10	Mechanical seal cover	Duplex stainless steel	EN 10088-1-X2CrNiMoN22-5-3 (1.4462)	A276/A790-S31803
11	Mechanical seal	Carbon graphite / Aluminium oxide		
12	Bush bearings	Carbon graphite		
13	Elastomers	NBR		
14	Motor sleeve	Stainless steel	EN 10088-1X1NiCrMoCu25-20-5 (1.4539)	AISI 904L
15	Lower bracket	Duplex stainless steel	EN 10213-4-GX2CrNiMoCuN25-6-3-3 (1.4517)	
16	Thrust bearing bracket	Duplex stainless steel	EN 10213-4-GX2CrNiMoCuN25-6-3-3 (1.4517)	
17	Filling valve	Duplex stainless steel	EN 10088-1-X2CrNiMoN22-5-3 (1.4462)	A276/A790-S31803
18	Diaphragm	EPDM		
19	Lower cover	Duplex stainless steel	EN 10213-4-GX2CrNiMoCuN25-6-3-3 (1.4517)	
20	Bolts and screws	Duplex stainless steel	EN 10088-1-X2CrNiMoN22-5-3 (1.4462)	A276/A790-S31803
	Cooling liquid	Water + antifreeze		

L8wr-2p50-en\_a\_tm

## CP8W MOTOR SERIES IDENTIFICATION CODE

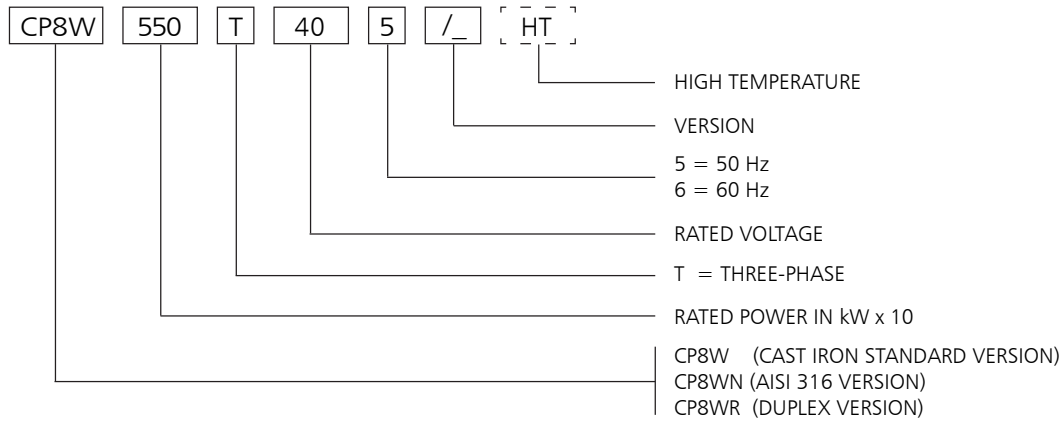

EXAMPLE : CP8W550T405/A HT

CP8W MOTOR :  
 RATED POWER 55 kW; THREE-PHASE;  
 RATED VOLTAGE 400 V; 50 Hz; /A VERSION; HIGH TEMPERATURE

## RATING PLATE

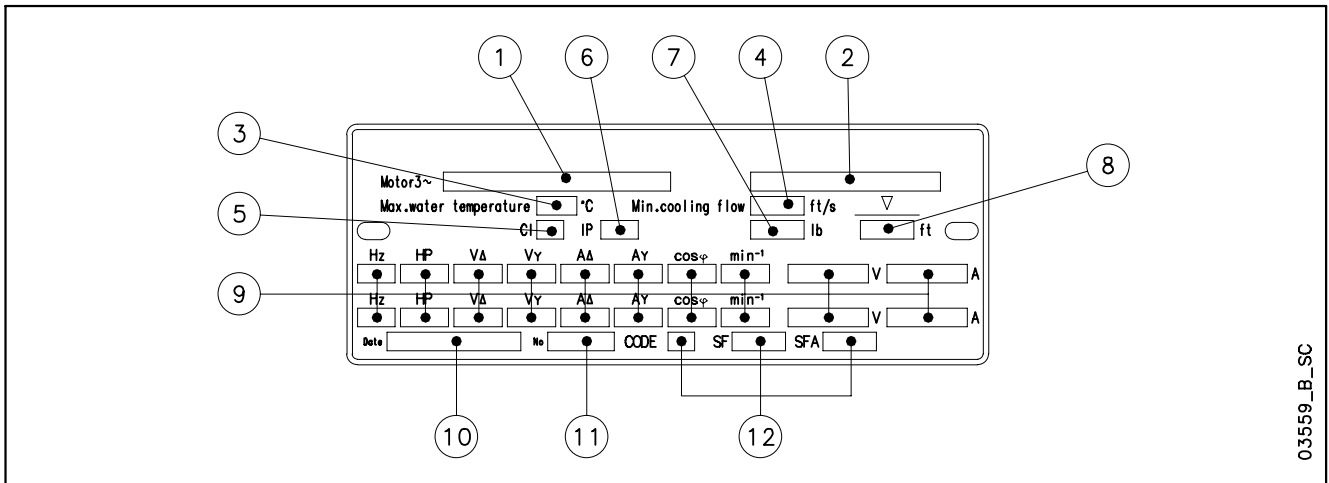

## LEGEND

- |                               |  |
|-------------------------------|--|
| 1 - Motor type                | 7 - Weight                             |
| 2 - Code                      | 8 - Maximum immersion depth            |
| 3 - Maximum water temperature | 9 - Operating characteristics          |
| 4 - Minimum water velocity    | 10 - Production date                   |
| 5 - Insulation class          | 11 - Serial number                     |
| 6 - Protection class          | 12 - Characteristics at service factor |

**CP8W MOTOR SERIES  
DIMENSIONS AND WEIGHTS AT 50 Hz**

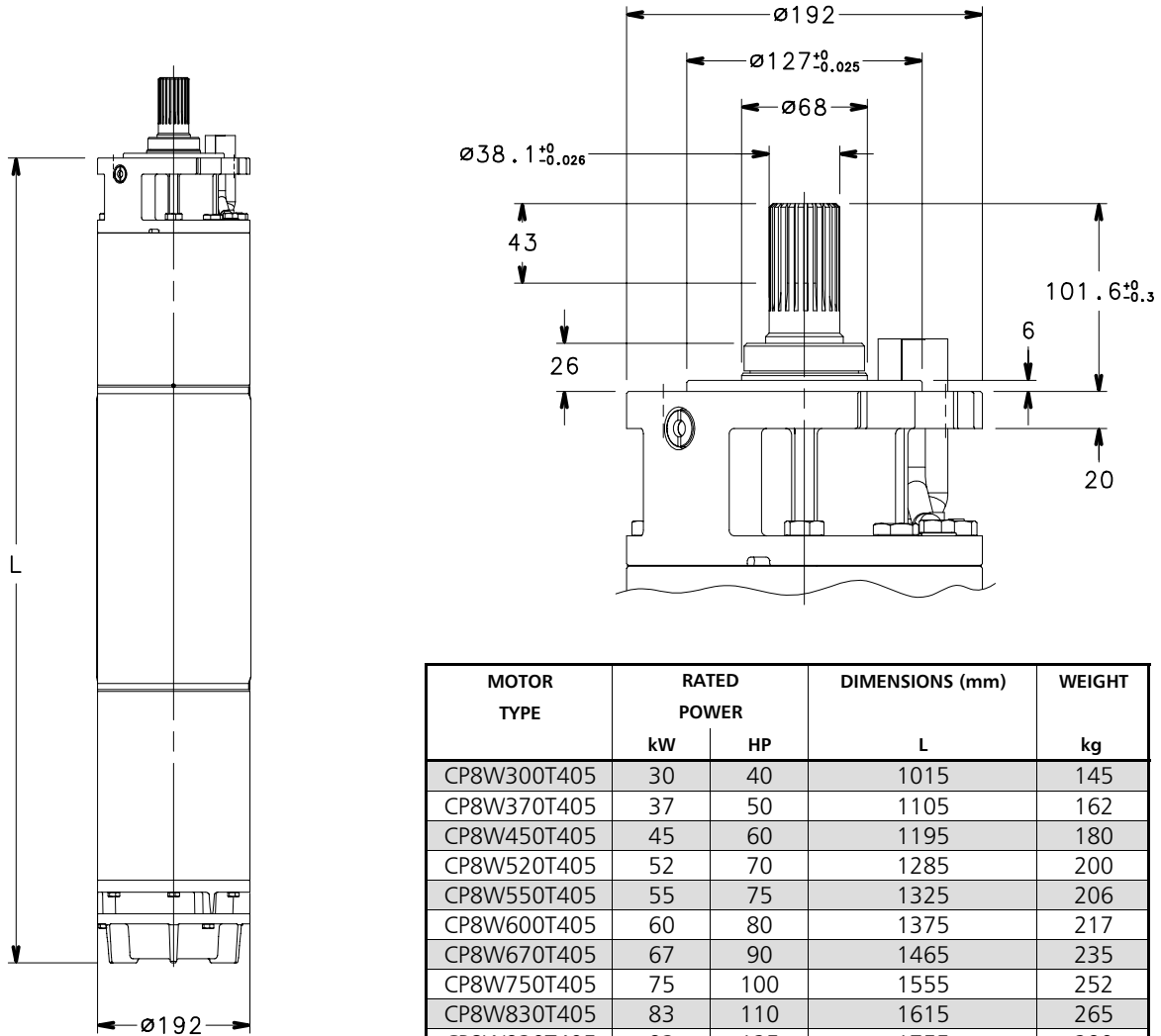

MOTOR TYPE	RATED POWER		DIMENSIONS (mm)	WEIGHT
	kW	HP	L	kg
CP8W300T405	30	40	1015	145
CP8W370T405	37	50	1105	162
CP8W450T405	45	60	1195	180
CP8W520T405	52	70	1285	200
CP8W550T405	55	75	1325	206
CP8W600T405	60	80	1375	217
CP8W670T405	67	90	1465	235
CP8W750T405	75	100	1555	252
CP8W830T405	83	110	1615	265
CP8W930T405	93	125	1755	290

cp8w-2p50-en\_a\_td

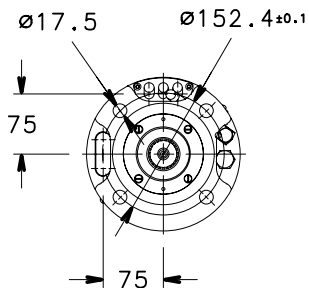

MOTOR TYPE	RATED POWER		DIMENSIONS (mm)	WEIGHT
	kW	HP	L	kg
CP8W300T405 HT	30	40	1105	162
CP8W370T405 HT	37	50	1195	180
CP8W450T405 HT	45	60	1285	200
CP8W520T405 HT	52	70	1325	206
CP8W550T405 HT	55	75	1375	217
CP8W600T405 HT	60	80	1465	235
CP8W670T405 HT	67	90	1555	252
CP8W750T405 HT	75	100	1615	265
CP8W830T405 HT	83	110	1755	290

cp8w-ht-2p50-en\_a\_td

03550\_C\_DD

## CP8W MOTOR SERIES THREE-PHASE OPERATING CHARACTERISTICS AT 50 Hz

MOTOR TYPE	RATED POWER		RATED VOLTAGE V	OPERATING CHARACTERISTICS AT RATED POWER				DIRECT START		MAX WATER TEMPERATURE °C	CABLE TYPE		
	THREE-PHASE kW	HP		RATED CURRENT A	rpm	η %	cosφ	Ts/Tn*	Is/In		Sec. (mm <sup>2</sup> )		
											DOL	Y/D	L (m)
CP8W300T405	30	40	380	65,0	2905	83,0	0,85	1,20	4,67	30	10	6	5,5
			400	62,0	2900	83,0	0,84	1,15	4,69				
			415	59,0	2900	83,0	0,84	1,09	4,70				
CP8W370T405	37	50	380	81,0	2840	80,5	0,87	1,04	4,19	30	10	6	5,5
			400	78,5	2860	81,0	0,84	1,14	4,54				
			415	76,0	2870	81,5	0,83	1,23	4,88				
CP8W450T405	45	60	380	92,0	2850	82,0	0,87	0,92	3,72	30	16	6	5,5
			400	89,0	2870	82,0	0,85	1,01	3,98				
			415	89,0	2880	83,5	0,83	1,09	4,23				
CP8W520T405	52	70	380	110	2840	82,0	0,86	1,14	3,90	30	16	6	5,5
			400	108	2865	82,0	0,85	1,15	4,20				
			415	104	2885	82,5	0,82	1,16	4,50				
CP8W550T405	55	75	380	118	2840	82,0	0,87	1,26	3,57	30	16	10	5,5
			400	114	2870	82,0	0,85	1,27	3,88				
			415	110	2885	82,5	0,83	1,27	4,19				
CP8W600T405	60	80	380	124	2855	82,0	0,87	1,12	4,18	30	16	10	5,5
			400	120	2875	82,5	0,85	1,23	4,49				
			415	118	2885	83,5	0,83	1,33	4,80				
CP8W670T405	67	90	380	138	2850	82,5	0,88	0,98	4,22	30	25	10	5,5
			400	133	2870	83,0	0,86	1,07	4,52				
			415	132	2885	83,5	0,83	1,16	4,82				
CP8W750T405	75	100	380	156	2860	82,0	0,87	0,92	4,10	30	25	16	5,5
			400	152	2875	82,5	0,85	1,01	4,41				
			415	148	2885	83,0	0,82	1,10	4,72				
CP8W830T405	83	110	380	172	2860	83,0	0,87	0,91	4,12	30	35	16	5,5
			400	168	2870	83,5	0,84	1,00	4,39				
			415	163	2880	84,0	0,82	1,08	4,66				
CP8W930T405	93	125	380	192	2850	83,0	0,87	0,84	3,38	30	35	16	5,5
			400	186	2860	83,5	0,85	0,92	3,84				
			415	180	2885	84,0	0,83	1,00	4,30				

\* Ts/Tn = ratio between starting torque and nominal torque.

cp8w-2p50-en\_d\_te

## CP8W HT MOTOR SERIES THREE-PHASE OPERATING CHARACTERISTICS AT 50 Hz

MOTOR TYPE	RATED POWER		RATED VOLTAGE V	OPERATING CHARACTERISTICS AT RATED POWER				DIRECT START		MAX WATER TEMPERATURE °C	CABLE TYPE		
	THREE-PHASE kW	HP		RATED CURRENT A	rpm	η %	cosφ	Ts/Tn*	Is/In		Sec. (mm <sup>2</sup> )		
											DOL	Y/D	L (m)
CP8W300T405 HT	30	40	380	66,6	2865	82,5	0,84	1,29	5,10	45	10	6	5,5
			400	64,5	2885	83,0	0,81	1,41	5,52				
			415	62,4	2895	83,5	0,8	1,53	5,94				
CP8W370T405 HT	37	50	380	77,5	2865	84,0	0,86	1,12	4,41	45	16	6	5,5
			400	75,0	2885	84,0	0,84	1,23	4,72				
			415	75,0	2895	85,5	0,82	1,33	5,02				
CP8W450T405 HT	45	60	380	97,8	2860	83,0	0,83	1,33	4,39	45	16	6	5,5
			400	96,0	2885	83,0	0,82	1,34	4,73				
			415	92,4	2905	83,5	0,79	1,35	5,06				
CP8W520T405 HT	52	70	380	110	2835	83,0	0,86	1,33	3,84	45	16	10	5,5
			400	106	2865	83,0	0,84	1,34	4,17				
			415	102	2880	83,5	0,82	1,34	4,51				
CP8W550T405 HT	55	75	380	117	2865	83,5	0,86	1,23	4,44	45	16	10	5,5
			400	113	2885	84,0	0,84	1,34	4,77				
			415	111	2895	85,0	0,82	1,46	5,10				
CP8W600T405 HT	60	80	380	127	2860	83,5	0,87	1,10	4,60	45	25	10	5,5
			400	122	2880	84,0	0,85	1,20	4,93				
			415	121	2895	84,5	0,82	1,30	5,25				
CP8W670T405 HT	67	90	380	141	2870	82,5	0,85	1,03	4,55	45	25	16	5,5
			400	137	2885	83,0	0,83	1,13	4,89				
			415	133	2895	83,5	0,8	1,24	5,24				
CP8W750T405 HT	75	100	380	156	2905	82,5	0,86	1,02	4,55	45	35	16	5,5
			400	152	2915	83,0	0,83	1,12	4,85				
			415	147	2925	83,5	0,81	1,21	5,15				
CP8W830T405 HT	83	110	380	171	2875	84,5	0,86	0,95	3,79	45	35	16	5,5
			400	166	2885	85,0	0,84	1,04	4,30				
			415	161	2910	85,5	0,82	1,13	4,82				

\* Ts/Tn = ratio between starting torque and nominal torque.

cp8w-ht-2p50-en\_a\_te





## 10" Submersible motors

### CP10W Series



Water filled submersible motors.

The robust design together with excellent choice of materials ensures optimal performance, ease of installation and reliability in all applications. For extremely demanding operation as high water temperature or aggressive environments special versions are available.

#### SPECIFICATIONS

- **Stainless steel** outer sleeve.
- **Rewindable stator.**
- **Class Y insulation.**
- Protection class: **IP68.**
- Compensating bellows for internal liquid expansion.
- Axial load supported by Kingsbury type thrust bearing.
- **Mechanical seal** protected by sand guard.
- Maximum **immersion depth:** 350 m.
- Maximum **number of starts per hour** at regular intervals: 8.
- Maximum supply **voltage variations** allowed :  $\pm 10\%$ .
- Maximum water **temperature:** 30°C.  
Max. temperature applies to motors working in a installation capable of delivering a flow of water around the motor jacket of at least 0,5 m/s.
- **Axial thrust:** 65000 N from 93 to 150 kW.
- **Power supply** cable suitable for drinkable water.
- **Versions:**
  - Three-phase: 93 to 150 kW 380-415 V, 50 Hz.
- **Horizontal operation:** valid for all versions provided that the direction of the axial thrust generated by the impellers is always from the pump to the motor.

#### SPECIAL VERSIONS

- Motors with double cable outlet for star/delta start.
- **CP10WN series:** complete range available realized of AISI 316 stainless steel.
- **CP10WR series:** complete range available realized of Duplex stainless steel.
- **HT series:** complete range available for all the CP10W/N/R construction, realized for applications in high temperature environments (**up to 60°C**) or under inverter.

#### OPTIONAL FEATURES

- Silicon Carbide mechanical seal.
- Special voltages.

#### ACCESSORIES

- Temperature sensor **PT 100 / PTC.**

**Rewindable stator**

**Thrust bearing Kingsbury type**

**Mechanical seal**

**CP10W - CP10WN - CP10WR MOTOR SERIES  
 MOTOR CROSS SECTION**

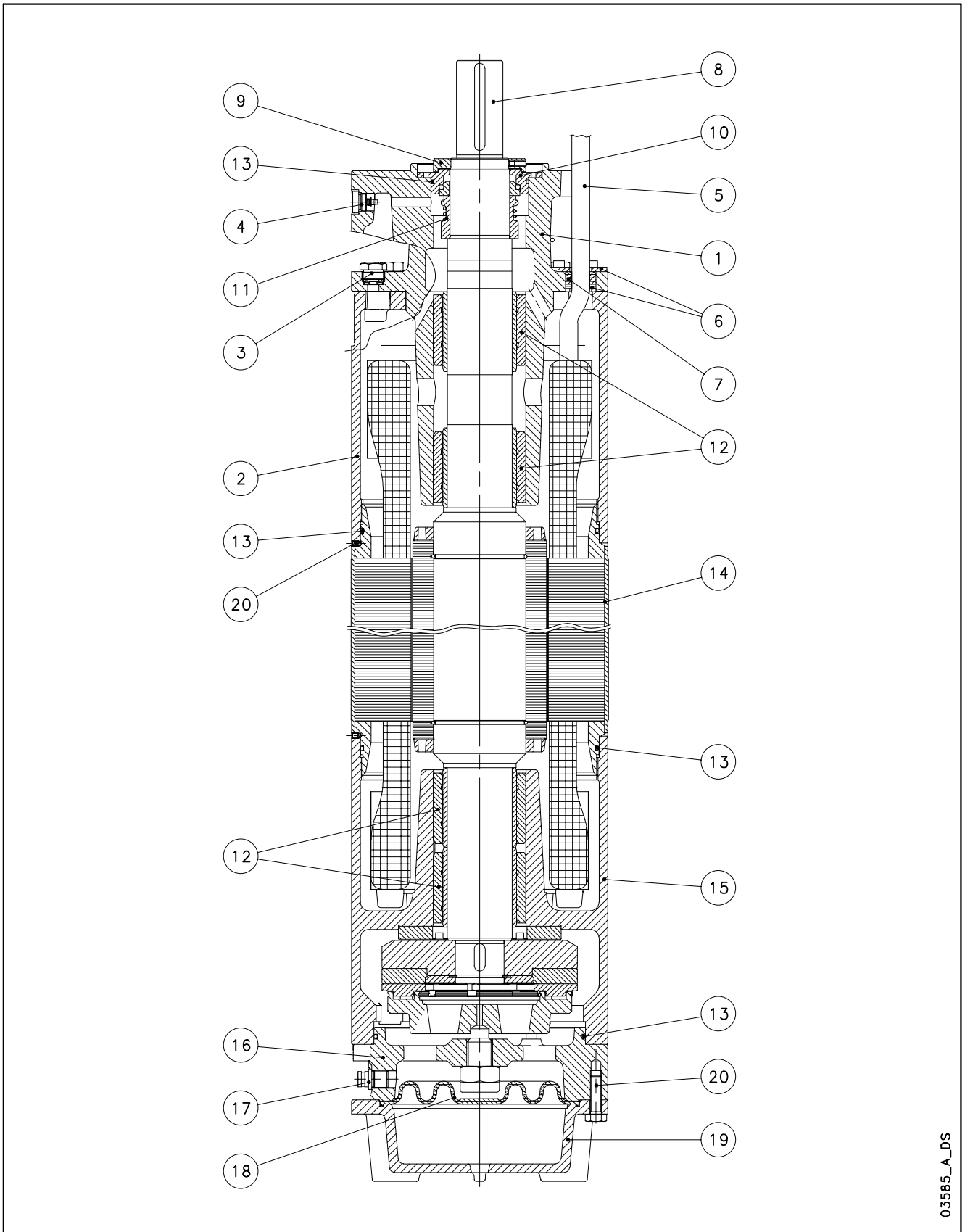

03585\_A\_DS

## CP10W TABLE OF MATERIALS

REF. N°	PART	MATERIAL	DESIGNATION	
			EUROPE	USA
1	Upper bracket	Cast iron	EN-GJL-200	Class 25 B
2	Spacer	Cast iron	EN-GJL-200	Class 25 B
3	Filling plug + OR	Stainless steel+NBR	EN 10088-1-X5CrNiMo17-12-2 (1.4401)	AISI 316
4	Vent valve	Stainless steel	EN 10088-1-X5CrNiMo17-12-2 (1.4401)	AISI 316
5	Cable	EPR		
6	Cable gland plate	Stainless steel	EN 10088-1-X5CrNi18-10 (1.4301)	AISI304
7	Cable gland	EPDM		
8	Shaft end	Duplex stainless steel	EN 10088-1-X2CrNiMoN22-5-3 (1.4462)	A276/A790-S31803
9	Removable sand guard	Stainless steel	EN 10088-1-X2CrNiMo17-12-2 (1.4404)	AISI 316L
10	Mechanical seal cover	Stainless steel	EN 10088-1-X2CrNiMo17-12-2 (1.4404)	AISI 316L
11	Mechanical seal	Carbon graphite / Aluminium oxide		
12	Bush bearings	Carbon graphite		
13	Elastomers	NBR		
14	Motor sleeve	Stainless steel	EN 10088-1-X2CrNi19-11 (1.4306)	AISI304L
15	Lower bracket	Cast iron	EN-GJL-200	Class 25 B
16	Thrust bearing bracket	Cast iron	EN-GJL-200	Class 25 B
17	Filling valve	Stainless steel	EN 10088-1-X5CrNiMo17-12-2 (1.4401)	AISI 316
18	Diaphragm	EPDM		
19	Lower cover	Cast iron	EN-GJL-200	Class 25 B
20	Bolts and screws	Stainless steel	EN 10088-1-X5CrNi18-10 (1.4301)	AISI304
	Cooling liquid	Water + antifreeze		

L10w-2p50-en\_a\_tm

## CP10WN TABLE OF MATERIALS

REF. N°	PART	MATERIAL	DESIGNATION	
			EUROPE	USA
1	Upper bracket	Stainless steel	EN 10213-4 - GX5CrNiMo19-11-2 (1.4408)	ASTM CF-8M (AISI 316 cast)
2	Spacer	Stainless steel	EN 10213-4 - GX5CrNiMo19-11-2 (1.4408)	ASTM CF-8M (AISI 316 cast)
3	Filling plug + OR	Stainless steel+NBR	EN 10088-1-X5CrNiMo17-12-2 (1.4401)	AISI 316
4	Vent valve	Stainless steel	EN 10088-1-X5CrNiMo17-12-2 (1.4401)	AISI 316
5	Cable	EPR		
6	Cable gland plate	Stainless steel	EN 10088-1-X5CrNiMo17-12-2 (1.4401)	AISI 316
7	Cable gland	EPDM		
8	Shaft end	Duplex stainless steel	EN 10088-1-X2CrNiMoN22-5-3 (1.4462)	A276/A790-S31803
9	Removable sand guard	Stainless steel	EN 10088-1-X2CrNiMo17-12-2 (1.4404)	AISI 316L
10	Mechanical seal cover	Stainless steel	EN 10088-1-X2CrNiMo17-12-2 (1.4404)	AISI 316L
11	Mechanical seal	Carbon graphite / Aluminium oxide		
12	Bush bearings	Carbon graphite		
13	Elastomers	NBR		
14	Motor sleeve	Stainless steel	EN 10088-1-X2CrNiMo17-12-2 (1.4404)	AISI 316L
15	Lower bracket	Stainless steel	EN 10213-4 - GX5CrNiMo19-11-2 (1.4408)	ASTM CF-8M (AISI 316 cast)
16	Thrust bearing bracket	Stainless steel	EN 10213-4 - GX5CrNiMo19-11-2 (1.4408)	ASTM CF-8M (AISI 316 cast)
17	Filling valve	Stainless steel	EN 10088-1-X5CrNiMo17-12-2 (1.4401)	AISI 316
18	Diaphragm	EPDM		
19	Lower cover	Stainless steel	EN 10213-4 - GX5CrNiMo19-11-2 (1.4408)	ASTM CF-8M (AISI 316 cast)
20	Bolts and screws	Stainless steel	EN 10088-1-X5CrNiMo17-12-2 (1.4401)	AISI 316
	Cooling liquid	Water + antifreeze		

L10wn-2p50-en\_a\_tm

## CP10WR TABLE OF MATERIALS

REF. N°	PART	MATERIAL	DESIGNATION	
			EUROPE	USA
1	Upper bracket	Duplex stainless steel	EN 10213-4-GX2CrNiMoCuN25-6-3-3 (1.4517)	
2	Spacer	Duplex stainless steel	EN 10213-4-GX2CrNiMoCuN25-6-3-3 (1.4517)	
3	Filling plug + OR	Duplex s. s.+NBR	EN 10088-1-X2CrNiMoN22-5-3 (1.4462)	A276/A790-S31803
4	Vent valve	Duplex stainless steel	EN 10088-1-X2CrNiMoN22-5-3 (1.4462)	A276/A790-S31803
5	Cable	EPR		
6	Cable gland plate	Stainless steel	EN 10088-1X1NiCrMoCu25-20-5 (1.4539)	AISI 904L
7	Cable gland	EPDM		
8	Shaft end	Duplex stainless steel	EN 10088-1-X2CrNiMoN22-5-3 (1.4462)	A276/A790-S31803
9	Removable sand guard	Duplex stainless steel	EN 10088-1-X2CrNiMoN22-5-3 (1.4462)	A276/A790-S31803
10	Mechanical seal cover	Duplex stainless steel	EN 10088-1-X2CrNiMoN22-5-3 (1.4462)	A276/A790-S31803
11	Mechanical seal	Carbon graphite / Aluminium oxide		
12	Bush bearings	Carbon graphite		
13	Elastomers	NBR		
14	Motor sleeve	Stainless steel	EN 10088-1X1NiCrMoCu25-20-5 (1.4539)	AISI 904L
15	Lower bracket	Duplex stainless steel	EN 10213-4-GX2CrNiMoCuN25-6-3-3 (1.4517)	
16	Thrust bearing bracket	Duplex stainless steel	EN 10213-4-GX2CrNiMoCuN25-6-3-3 (1.4517)	
17	Filling valve	Duplex stainless steel	EN 10088-1-X2CrNiMoN22-5-3 (1.4462)	A276/A790-S31803
18	Diaphragm	EPDM		
19	Lower cover	Duplex stainless steel	EN 10213-4-GX2CrNiMoCuN25-6-3-3 (1.4517)	
20	Bolts and screws	Duplex stainless steel	EN 10088-1-X2CrNiMoN22-5-3 (1.4462)	A276/A790-S31803
	Cooling liquid	Water + antifreeze		

L10wr-2p50-en\_a\_tm

## CP10W MOTOR SERIES IDENTIFICATION CODE

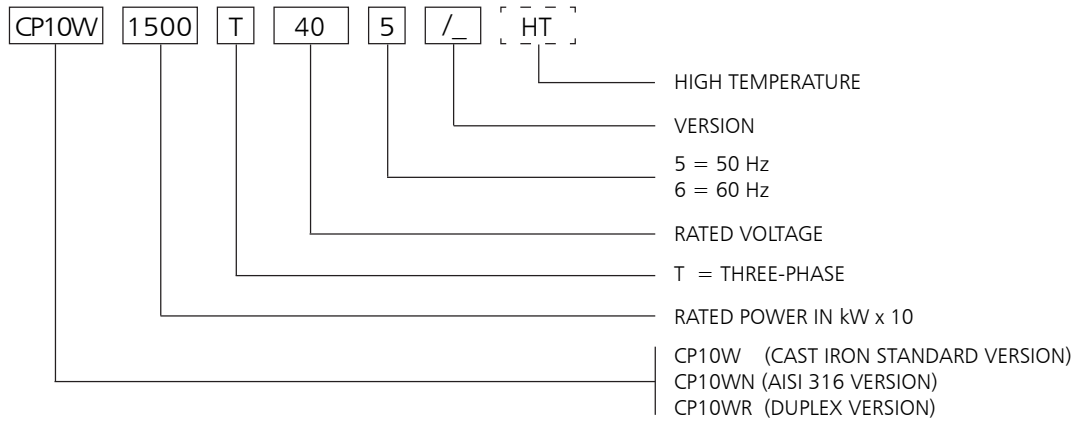

EXAMPLE : CP10W1500T405/A HT

CP10W MOTOR :  
 RATED POWER 150 kW; THREE-PHASE;  
 RATED VOLTAGE 400 V; 50 Hz; /A VERSION; HIGH TEMPERATURE

## RATING PLATE

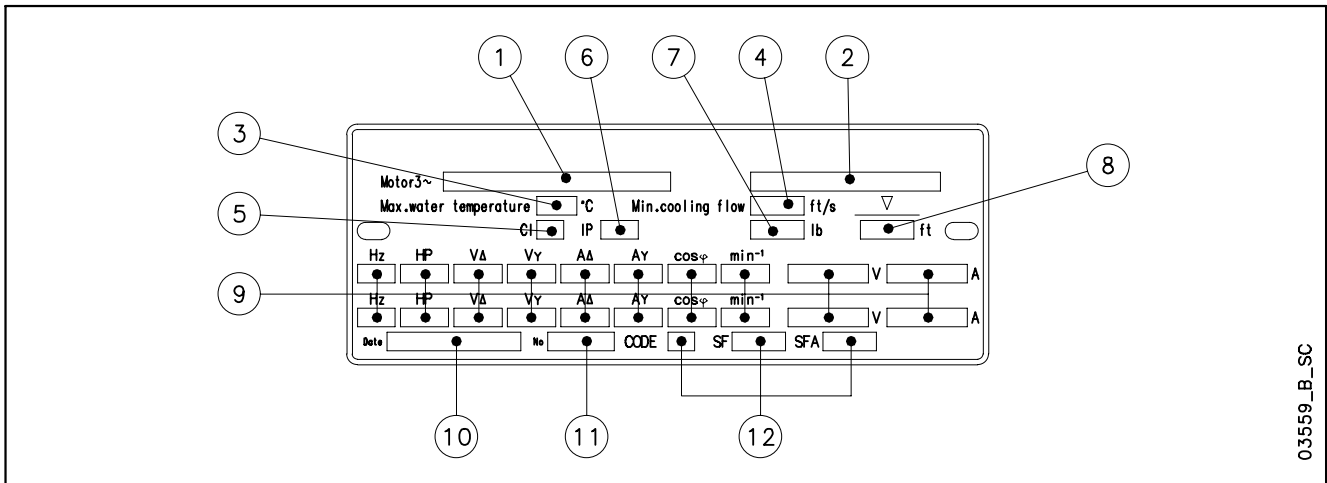

## LEGEND

- 1 - Motor type
- 2 - Code
- 3 - Maximum water temperature
- 4 - Minimum water velocity
- 5 - Insulation class
- 6 - Protection class
- 7 - Weight
- 8 - Maximum immersion depth
- 9 - Operating characteristics
- 10 - Production date
- 11 - Serial number
- 12 - Characteristics at service factor

**CP10W MOTOR SERIES  
DIMENSIONS AND WEIGHTS AT 50 Hz**

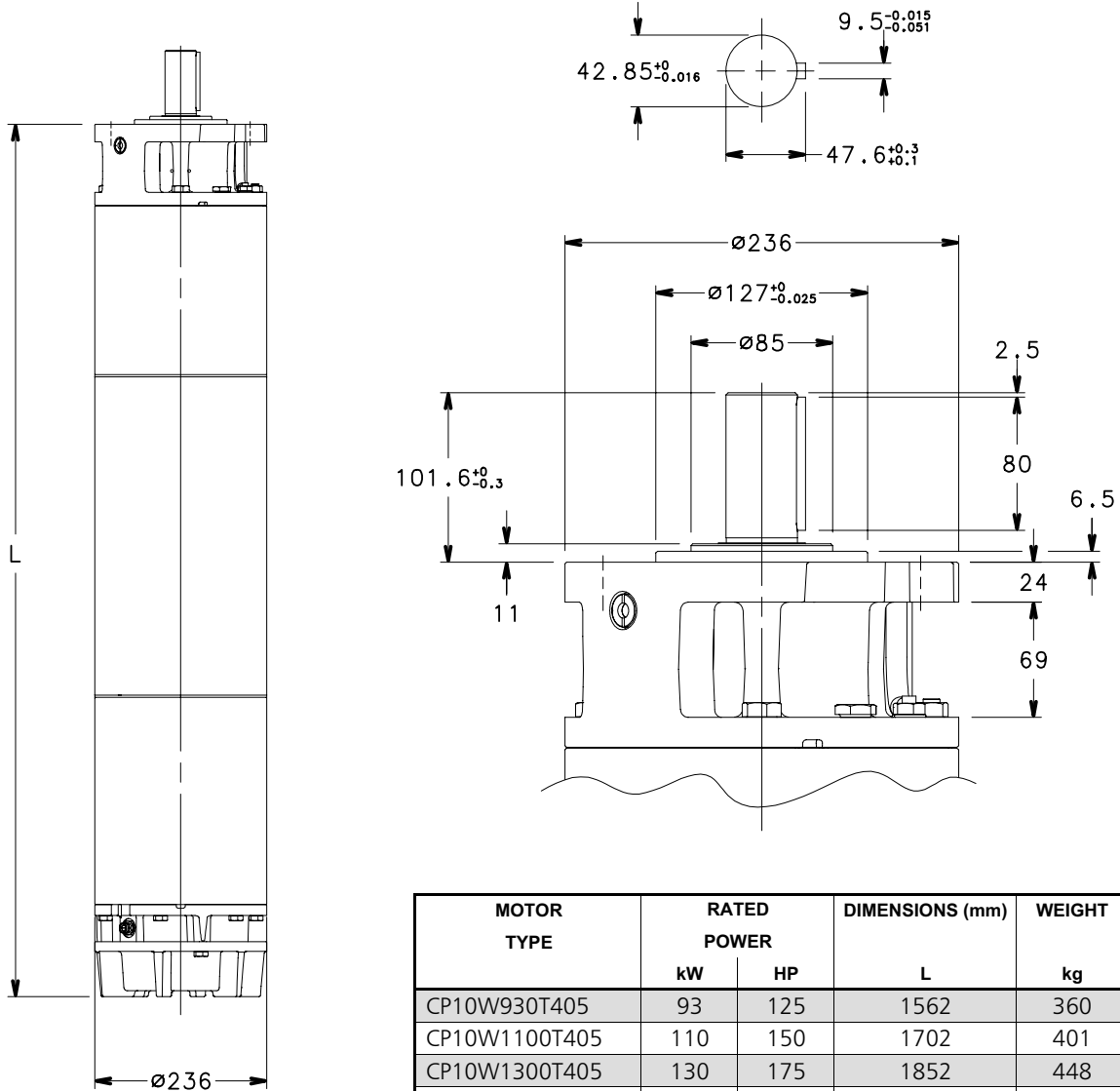

MOTOR TYPE	RATED POWER		DIMENSIONS (mm)	WEIGHT
	kW	HP	L	kg
CP10W930T405	93	125	1562	360
CP10W1100T405	110	150	1702	401
CP10W1300T405	130	175	1852	448
CP10W1500T405	150	200	1982	487

cp10w-2p50-en\_a\_td

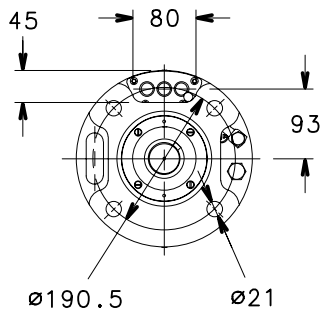

MOTOR TYPE	RATED POWER		DIMENSIONS (mm)	WEIGHT
	kW	HP	L	kg
CP10W830T405 HT	83	110	1562	360
CP10W930T405 HT	93	125	1702	401
CP10W1100T405 HT	110	150	1852	448
CP10W1300T405 HT	130	175	1982	487

cp10w-ht-2p50-en\_a\_td

0.3554\_C\_DD

## CP10W MOTOR SERIES THREE-PHASE OPERATING CHARACTERISTICS AT 50 Hz

MOTOR TYPE  THREE-PHASE	RATED POWER		RATED VOLTAGE  V	OPERATING CHARACTERISTICS AT RATED POWER				DIRECT START		MAX WATER TEMPERATURE  °C	CABLE TYPE		
	kW	HP		RATED CURRENT  A	rpm	η %	cosφ	Ts/Tn*	Is/In		Sec. (mm <sup>2</sup> )		
											DOL	Y/D	L (m)
CP10W930T405	93	125	380	191	2895	83,0	0,87	1,02	5,14	30	35	25	5
			400	184	2910	83,0	0,85	1,12	5,55				
			415	180	2915	84,0	0,84	1,21	5,95				
CP10W1100T405	110	150	380	235	2900	83,5	0,86	1,20	4,77	30	50	25	5
			400	225	2910	83,5	0,84	1,32	5,17				
			415	220	2920	84,5	0,82	1,43	5,57				
CP10W1300T405	130	175	380	270	2895	84,0	0,86	1,29	4,84	30	50	25	5
			400	263	2915	83,0	0,85	1,42	5,22				
			415	255	2915	85,5	0,83	1,54	5,60				
CP10W1500T405	150	200	380	308	2905	83,0	0,86	1,26	4,77	30	70	25	5
			400	295	2915	83,0	0,85	1,38	5,20				
			415	285	2925	84,0	0,84	1,50	5,63				

\* Ts/Tn = ratio between starting torque and nominal torque.

cp10w-2p50-en\_b\_te

## CP10W HT MOTOR SERIES THREE-PHASE OPERATING CHARACTERISTICS AT 50 Hz

MOTOR TYPE  THREE-PHASE	RATED POWER		RATED VOLTAGE  V	OPERATING CHARACTERISTICS AT RATED POWER				DIRECT START		MAX WATER TEMPERATURE  °C	CABLE TYPE		
	kW	HP		RATED CURRENT  A	rpm	η %	cosφ	Ts/Tn*	Is/In		Sec. (mm <sup>2</sup> )		
											DOL	Y/D	L (m)
CP10W830T405 HT	83	110	380	170,2	2900	85,0	0,87	1,14	5,77	45	35	25	5
			400	164,0	2915	85,0	0,85	1,25	6,22				
			415	160,4	2920	86,0	0,84	1,36	6,68				
CP10W930T405 HT	93	125	380	200,5	2905	86,0	0,84	1,42	5,59	45	50	25	5
			400	192,0	2915	86,0	0,82	1,56	6,06				
			415	187,7	2925	87,0	0,8	1,69	6,53				
CP10W1100T405 HT	110	150	380	233,0	2900	87,0	0,82	1,53	5,61	45	50	25	5
			400	227,0	2920	86,0	0,81	1,68	6,05				
			415	220,1	2920	88,6	0,79	1,82	6,49				
CP10W1300T405 HT	130	175	380	288,2	2920	85,0	0,83	1,46	5,10	45	70	25	5
			400	276,0	2930	85,0	0,82	1,60	5,56				
			415	266,6	2940	86,0	0,81	1,74	6,02				

\* Ts/Tn = ratio between starting torque and nominal torque.

cp10w-ht-2p50-en\_a\_te

## 12" Submersible motors

### CP12W Series



Water filled submersible motors.

The robust design together with excellent choice of materials ensures optimal performance, ease of installation and reliability in all applications. For extremely demanding operation as high water temperature or aggressive environments special versions are available.

#### SPECIFICATIONS

- **Stainless steel** outer sleeve.
- **Rewindable stator.**
- **Class Y insulation.**
- Protection class: **IP68.**
- Compensating bellows for internal liquid expansion.
- Axial load supported by Kingsbury type thrust bearing.
- **Mechanical seal** protected by sand guard.
- Maximum **immersion depth:** 350 m.
- Maximum **number of starts per hour** at regular intervals: 4.
- Maximum supply **voltage variations** allowed :  $\pm 10\%$ .
- Maximum water **temperature:** 30°C.  
Max. temperature applies to motors working in a installation capable of delivering a flow of water around the motor jacket of at least 0,5 m/s.
- **Axial thrust:** 65000 N from 185 to 300 kW.
- **Power supply** cable suitable for drinkable water.
- **Versions:**
  - Three-phase: 185 to 300 kW 380-415 V, 50 Hz.
- **Horizontal operation:** valid for all versions provided that the direction of the axial thrust generated by the impellers is always from the pump to the motor.

#### SPECIAL VERSIONS

- Motors with double cable outlet for star/delta start.
- **CP12WN series:** complete range available realized of AISI 316 stainless steel.
- **CP12WR series:** complete range available realized of Duplex stainless steel.
- **HT series:** complete range available for all the CP12W/N/R construction, realized for applications in high temperature environments (**up to 60°C**) or under inverter.

#### OPTIONAL FEATURES

- Silicon Carbide mechanical seal.
- Special voltages.

#### ACCESSORIES

- Temperature sensor **PT 100 / PTC.**

**Rewindable stator**

**Thrust bearing Kingsbury type**

**Mechanical seal**

**CP12W - CP12WN - CP12WR MOTOR SERIES  
 MOTOR CROSS SECTION**

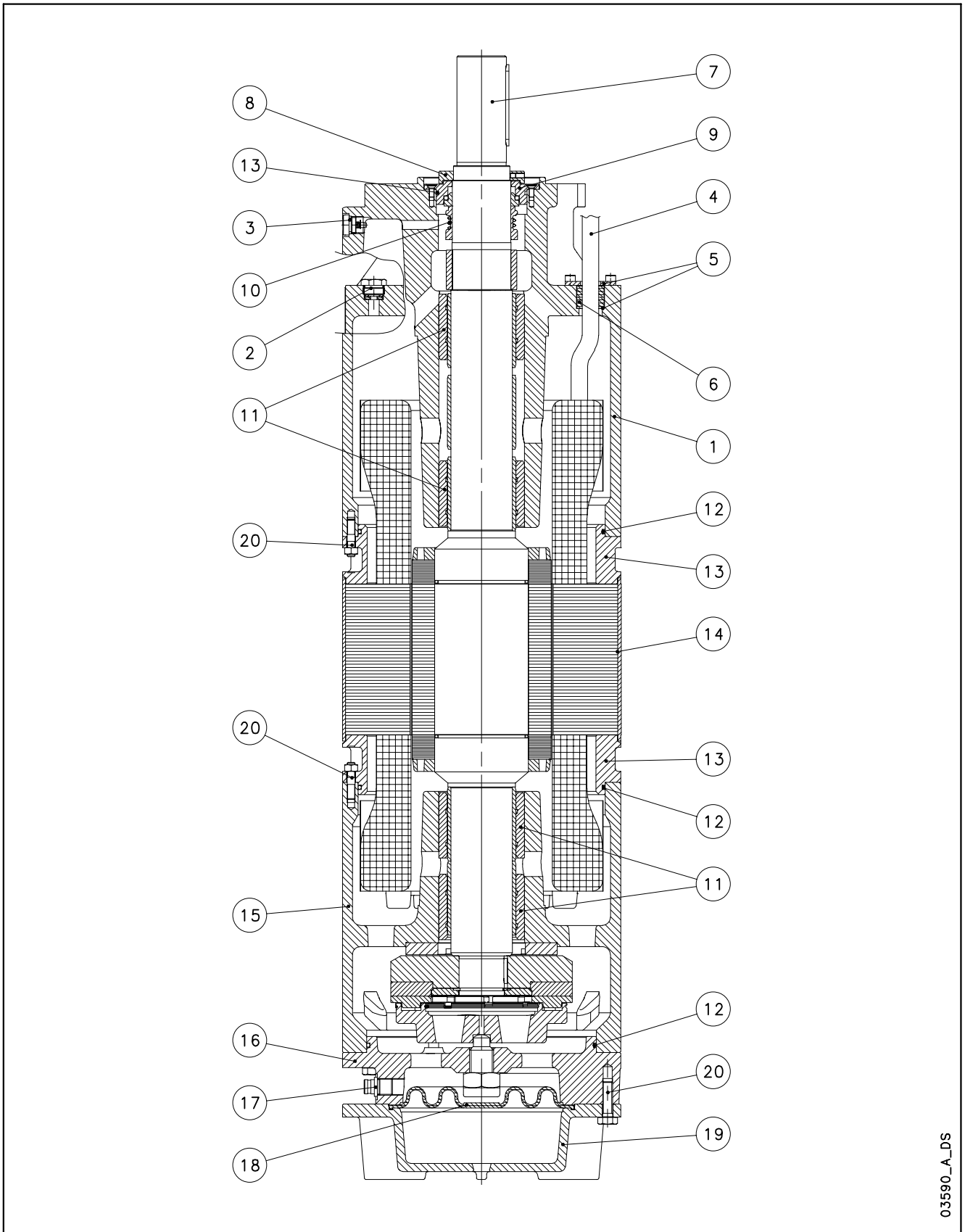

03590\_A\_DS



## CP12W TABLE OF MATERIALS

REF. N°	PART	MATERIAL	DESIGNATION	
			EUROPE	USA
1	Upper bracket	Cast iron	EN-GJL-200	Class 25 B
2	Filling plug + OR	Stainless steel+NBR	EN 10088-1-X5CrNiMo17-12-2 (1.4401)	AISI 316
3	Vent valve	Stainless steel	EN 10088-1-X5CrNiMo17-12-2 (1.4401)	AISI 316
4	Cable	EPR		
5	Cable gland plate	Stainless steel	EN 10088-1-X5CrNiMo17-12-2 (1.4401)	AISI 316
6	Cable gland	EPDM		
7	Shaft end	Duplex stainless steel	EN 10088-1-X2CrNiMoN22-5-3 (1.4462)	A276/A790-S31803
8	Removable sand guard	Stainless steel	EN 10088-1-X2CrNiMo17-12-2 (1.4404)	AISI 316L
9	Mechanical seal cover	Stainless steel	EN 10088-1-X2CrNiMo17-12-2 (1.4404)	AISI 316L
10	Mechanical seal	Carbon graphite / Aluminium oxide		
11	Bush bearings	Carbon graphite		
12	Elastomers	NBR		
13	Stator flanges	Steel	UNI 3158 - Fe 52	
14	Motor sleeve	Stainless steel	EN 10088-1-X2CrNi19-11 (1.4306)	AISI304L
15	Lower bracket	Cast iron	EN-GJL-200	Class 25 B
16	Thrust bearing bracket	Cast iron	EN-GJL-200	Class 25 B
17	Filling valve	Stainless steel	EN 10088-1-X5CrNiMo17-12-2 (1.4401)	AISI 316
18	Diaphragm	EPDM		
19	Lower cover	Cast iron	EN-GJL-200	Class 25 B
20	Bolts and screws	Stainless steel	EN 10088-1-X5CrNi18-10 (1.4301)	AISI304
	Cooling liquid	Water + antifreeze		

L12w-2p50-en\_a\_tm

## CP12WN TABLE OF MATERIALS

REF. N°	PART	MATERIAL	DESIGNATION	
			EUROPE	USA
1	Upper bracket	Stainless steel	EN 10213-4 - GX5CrNiMo19-11-2 (1.4408)	ASTM CF-8M (AISI 316 cast)
2	Filling plug + OR	Stainless steel+NBR	EN 10088-1-X5CrNiMo17-12-2 (1.4401)	AISI 316
3	Vent valve	Stainless steel	EN 10088-1-X5CrNiMo17-12-2 (1.4401)	AISI 316
4	Cable	EPR		
5	Cable gland plate	Stainless steel	EN 10088-1-X5CrNiMo17-12-2 (1.4401)	AISI 316
6	Cable gland	EPDM		
7	Shaft end	Duplex stainless steel	EN 10088-1-X2CrNiMoN22-5-3 (1.4462)	A276/A790-S31803
8	Removable sand guard	Stainless steel	EN 10088-1-X2CrNiMo17-12-2 (1.4404)	AISI 316L
9	Mechanical seal cover	Stainless steel	EN 10088-1-X2CrNiMo17-12-2 (1.4404)	AISI 316L
10	Mechanical seal	Carbon graphite / Aluminium oxide		
11	Bush bearings	Carbon graphite		
12	Elastomers	NBR		
13	Stator flanges	Stainless steel	EN 10088-1-X5CrNiMo17-12-2 (1.4401)	AISI 316
14	Motor sleeve	Stainless steel	EN 10088-1-X2CrNiMo17-12-2 (1.4404)	AISI 316L
15	Lower bracket	Stainless steel	EN 10213-4 - GX5CrNiMo19-11-2 (1.4408)	ASTM CF-8M (AISI 316 cast)
16	Thrust bearing bracket	Stainless steel	EN 10213-4 - GX5CrNiMo19-11-2 (1.4408)	ASTM CF-8M (AISI 316 cast)
17	Filling valve	Stainless steel	EN 10088-1-X5CrNiMo17-12-2 (1.4401)	AISI 316
18	Diaphragm	EPDM		
19	Lower cover	Stainless steel	EN 10213-4 - GX5CrNiMo19-11-2 (1.4408)	ASTM CF-8M (AISI 316 cast)
20	Bolts and screws	Stainless steel	EN 10088-1-X5CrNiMo17-12-2 (1.4401)	AISI 316
	Cooling liquid	Water + antifreeze		

L12wn-2p50-en\_a\_tm

## CP12WR TABLE OF MATERIALS

REF. N°	PART	MATERIAL	DESIGNATION	
			EUROPE	USA
1	Upper bracket	Duplex stainless steel	EN 10213-4-GX2CrNiMoCuN25-6-3-3 (1.4517)	
2	Filling plug + OR	Duplex s. s.+NBR	EN 10088-1-X2CrNiMoN22-5-3 (1.4462)	A276/A790-S31803
3	Vent valve	Duplex stainless steel	EN 10088-1-X2CrNiMoN22-5-3 (1.4462)	A276/A790-S31803
4	Cable	EPR		
5	Cable gland plate	Stainless steel	EN 10088-1X1NiCrMoCu25-20-5 (1.4539)	AISI 904L
6	Cable gland	EPDM		
7	Shaft end	Duplex stainless steel	EN 10088-1-X2CrNiMoN22-5-3 (1.4462)	A276/A790-S31803
8	Removable sand guard	Duplex stainless steel	EN 10088-1-X2CrNiMoN22-5-3 (1.4462)	A276/A790-S31803
9	Mechanical seal cover	Duplex stainless steel	EN 10088-1-X2CrNiMoN22-5-3 (1.4462)	A276/A790-S31803
10	Mechanical seal	Carbon graphite / Aluminium oxide		
11	Bush bearings	Carbon graphite		
12	Elastomers	NBR		
13	Stator flanges	Duplex stainless steel	EN 10213-4-GX2CrNiMoCuN25-6-3-3 (1.4517)	
14	Motor sleeve	Stainless steel	EN 10088-1X1NiCrMoCu25-20-5 (1.4539)	AISI 904L
15	Lower bracket	Duplex stainless steel	EN 10213-4-GX2CrNiMoCuN25-6-3-3 (1.4517)	
16	Thrust bearing bracket	Duplex stainless steel	EN 10213-4-GX2CrNiMoCuN25-6-3-3 (1.4517)	
17	Filling valve	Duplex stainless steel	EN 10088-1-X2CrNiMoN22-5-3 (1.4462)	A276/A790-S31803
18	Diaphragm	EPDM		
19	Lower cover	Duplex stainless steel	EN 10213-4-GX2CrNiMoCuN25-6-3-3 (1.4517)	
20	Bolts and screws	Duplex stainless steel	EN 10088-1-X2CrNiMoN22-5-3 (1.4462)	A276/A790-S31803
	Cooling liquid	Water + antifreeze		

L12wr-2p50-en\_a\_tm

## CP12W MOTOR SERIES IDENTIFICATION CODE

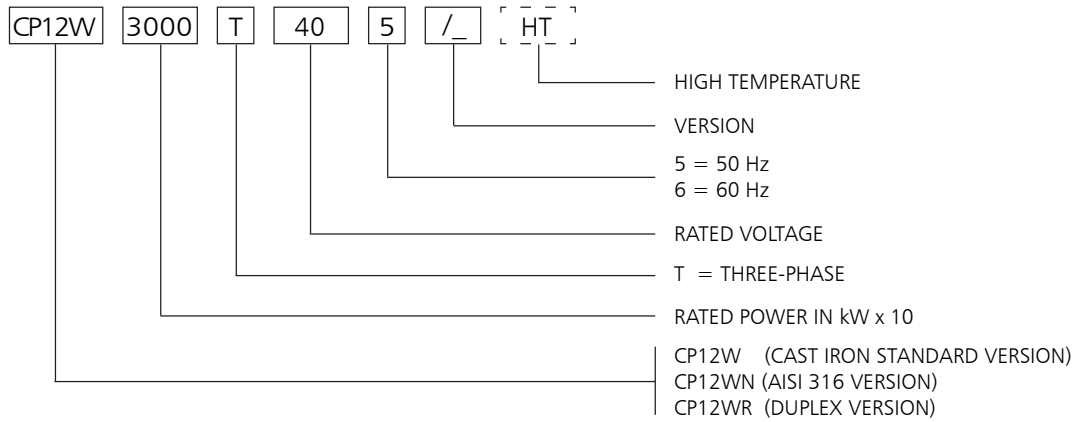

EXAMPLE : CP12W3000T405/A HT

CP12W MOTOR :  
RATED POWER 300 kW; THREE-PHASE;  
RATED VOLTAGE 400 V; 50 Hz; /A VERSION; HIGH TEMPERATURE

## RATING PLATE

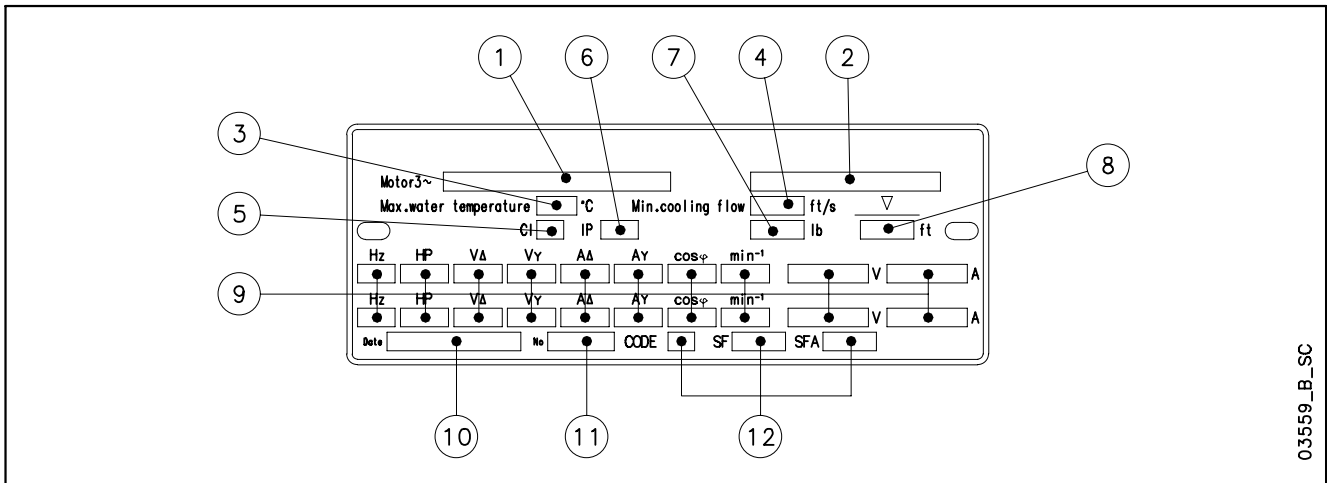

03559\_B\_SC

## LEGEND

- 1 - Motor type
- 2 - Code
- 3 - Maximum water temperature
- 4 - Minimum water velocity
- 5 - Insulation class
- 6 - Protection class
- 7 - Weight
- 8 - Maximum immersion depth
- 9 - Operating characteristics
- 10 - Production date
- 11 - Serial number
- 12 - Characteristics at service factor

**CP12W MOTOR SERIES  
DIMENSIONS AND WEIGHTS AT 50 Hz**

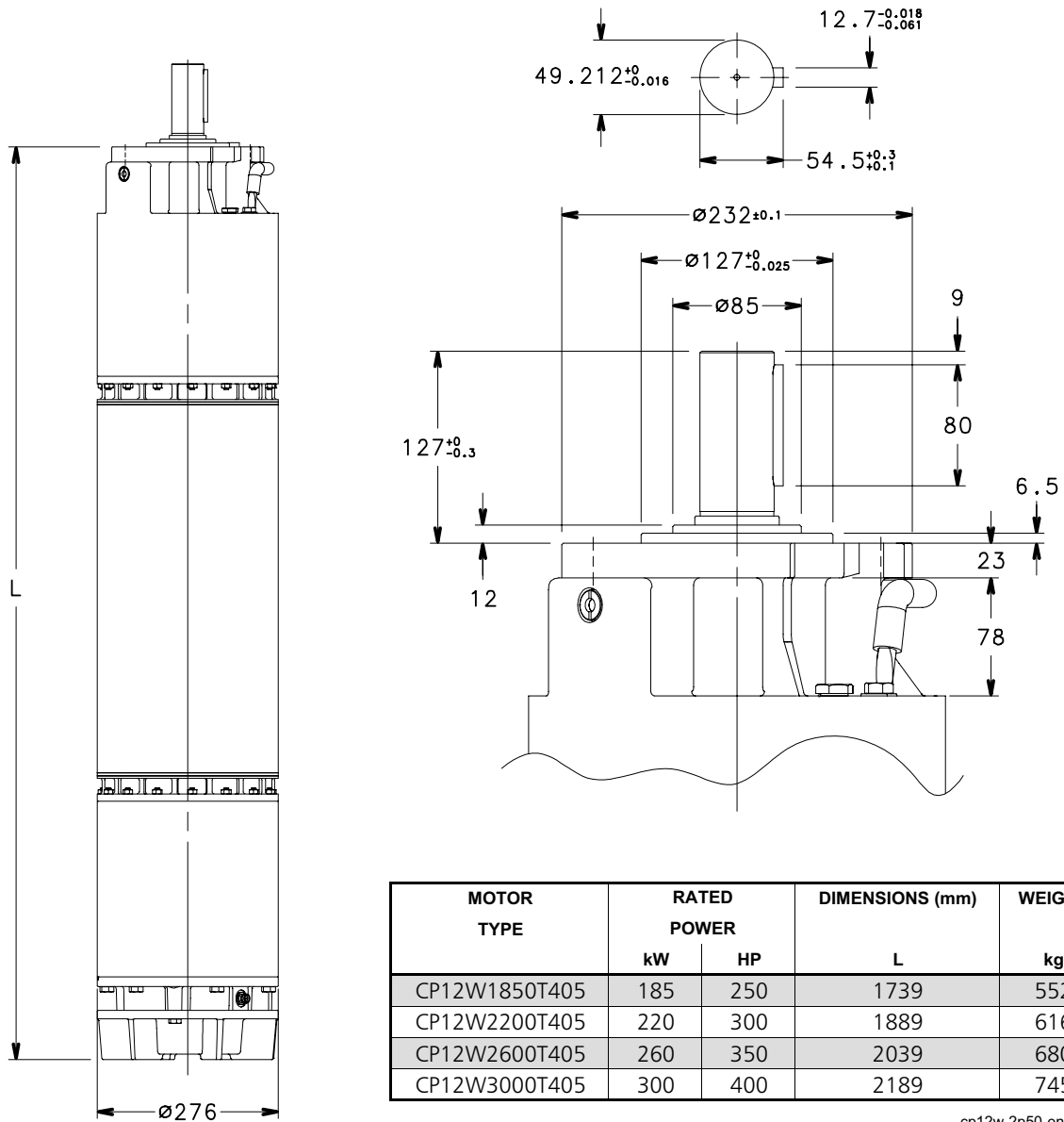

cp12w-2p50-en\_a\_td

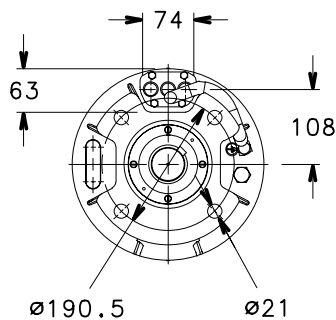

MOTOR TYPE	RATED POWER		DIMENSIONS (mm)	WEIGHT
	kW	HP	L	kg
CP12W1500T405 HT	150	200	1739	552
CP12W1850T405 HT	185	250	1889	616
CP12W2200T405 HT	220	300	2039	680
CP12W2600T405 HT	260	350	2189	745

cp12w-ht-2p50-es\_a\_td

0.35553\_C\_DD

## CP12W MOTOR SERIES THREE-PHASE OPERATING CHARACTERISTICS AT 50 Hz

MOTOR TYPE THREE-PHASE	RATED POWER		RATED VOLTAGE V	OPERATING CHARACTERISTICS AT RATED POWER				DIRECT START		MAX WATER TEMPERATURE °C	CABLE TYPE		
	kW	HP		RATED CURRENT A	rpm	η %	cosφ	Ts/Tn*	Is/In		Sec. (mm <sup>2</sup> ) DOL Y/D L (m)		
CP12W1850T405	185	250	380	380	2895	84,0	0,87	1,28	5,57	30	70	50	5
			400	370	2905	84,0	0,86	1,41	5,99				
			415	360	2915	84,5	0,86	1,53	6,40				
CP12W2200T405	220	300	380	470	2910	84,5	0,86	1,04	4,60	30	95	50	5
			400	456	2925	84,5	0,85	1,14	5,01				
			415	435	2930	85,5	0,83	1,24	5,42				
CP12W2600T405	260	350	380	525	2875	85,0	0,87	0,96	4,10	30	120	70	5
			400	512	2890	85,0	0,85	1,06	4,39				
			415	498	2910	86,0	0,83	1,15	4,67				
CP12W3000T405	300	400	380	620	2880	85,0	0,87	0,90	4,10	30	2x70	70	5
			400	594	2900	85,0	0,85	0,99	4,50				
			415	570	2910	86,0	0,84	1,08	4,90				

\* Ts/Tn = ratio between starting torque and nominal torque.

cp12w-2p50-en\_c\_te

## CP12W HT MOTOR SERIES THREE-PHASE OPERATING CHARACTERISTICS AT 50 Hz

MOTOR TYPE THREE-PHASE	RATED POWER		RATED VOLTAGE V	OPERATING CHARACTERISTICS AT RATED POWER				DIRECT START		MAX WATER TEMPERATURE °C	CABLE TYPE		
	kW	HP		RATED CURRENT A	rpm	η %	cosφ	Ts/Tn*	Is/In		Sec. (mm <sup>2</sup> ) DOL Y/D L (m)		
CP12W1500T405 HT	150	200	380	328,6	2930	87,0	0,82	1,60	6,44	45	70	50	5
			400	320,0	2940	87,0	0,81	1,75	6,92				
			415	311,4	2950	87,5	0,81	1,91	7,40				
CP12W1850T405 HT	185	250	380	379,3	2915	87,0	0,83	1,24	5,70	45	95	50	5
			400	368,0	2930	87,0	0,82	1,36	6,21				
			415	351,1	2935	88,0	0,8	1,48	6,72				
CP12W2200T405 HT	220	300	380	438,9	2915	88,0	0,86	1,15	4,90	45	120	70	5
			400	428,0	2930	88,0	0,84	1,26	5,25				
			415	416,3	2950	89,0	0,82	1,38	5,59				
CP12W2600T405 HT	260	350	380	545,9	2895	87,0	0,84	1,04	4,66	45	2x70	70	5
			400	523,0	2915	87,0	0,82	1,15	5,11				
			415	501,9	2925	88,0	0,81	1,25	5,57				

\* Ts/Tn = ratio between starting torque and nominal torque.

cp12w-ht-2p50-en\_a\_te

## **ACCESSORIES**

ISO Threaded Flanges .....	<b>78</b>
Supporting Collars .....	<b>80</b>
Motor - Control Panle Combination Table .....	<b>81</b>
Electrical Panels .....	<b>83</b>
Level control panels .....	<b>89</b>
Level probe module .....	<b>90</b>
Lightning protection .....	<b>91</b>
Cooling shrouds .....	<b>92</b>
Booster shroud .....	<b>94</b>

## ISO THREADED FLANGES

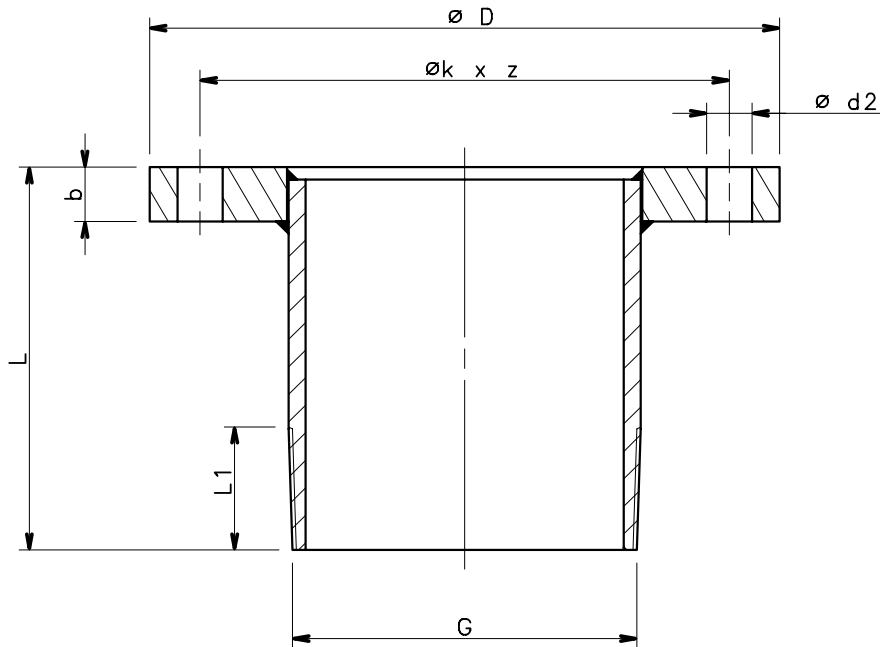

PUMP TYPE	THREADING G	Dimensions (mm)									
		Flange according to EN 1092-1								L	L1
		DN	PN	Ø D	Ø d	Ø k	b	Ø d2	Z		
GZ10150 GZ10220 GZ10275	EN 10226-1 R 6	150	10 ÷ 16	285	212	240	22	22	8	198	40
		150	25 ÷ 40	300	218	250	28	26	8	218	40
		150	63	345	218	280	36	33	8	238	40
		200	10	340	268	295	24	22	8	357	40
		200	16	340	268	295	24	22	12	357	40
		200	25	360	278	310	30	26	12	375	40
		200	40	375	285	320	34	30	12	383	40
GZ12340	ANSI B1.20.1 API 8 NPT	200	10	340	-	295	26	22	8	150	55
		200	16	340	-	295	30	22	12	150	55
		200	25	360	-	310	34	26	12	150	55
		200	40	375	-	320	40	30	12	150	55
		200	63	415	-	345	42	36	12	150	55

Material : Stainless steel EN 10088-1 - X6CrNiMoTi17-12-2 (1.4571) AISI 316Ti. (Other materials available on request).

gz-flange-r-en\_b\_td

**ANSI (API) THREADED FLANGE**

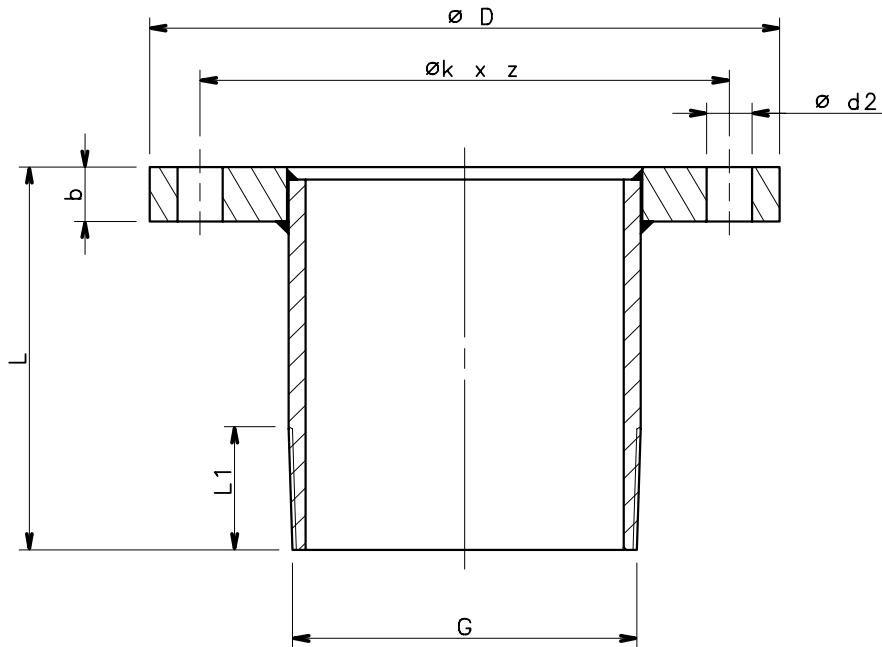

PUMP TYPE	THREADING EN 10226-1 G	Dimensions (mm)									
		Flange according to ASME B16.5								L	L1
		DN	Class	$\varnothing D$	$\varnothing d$	$\varnothing k$	b	$\varnothing d2$	Z		
GZ10150 GZ10220 GZ10275	R 6	6"	150	280	216	241	25	22	8	232	40
		6"	300	317	216	270	37	22	12	242	40
		6"	600	356	216	292	54	29	12	266	40
		8"	150	343	270	298	28	22	8	397	40
		8"	300	381	270	330	41	25	12	406	40
		8"	600	419	270	349	62	32	12	434	40

Material : Stainless steel EN 10088-1 - X6CrNiMoTi17-12-2 (1.4571) AISI 316Ti. (Other materials available on request).

gz-flange-api-en\_b\_td

## CARRYING CLAMPS

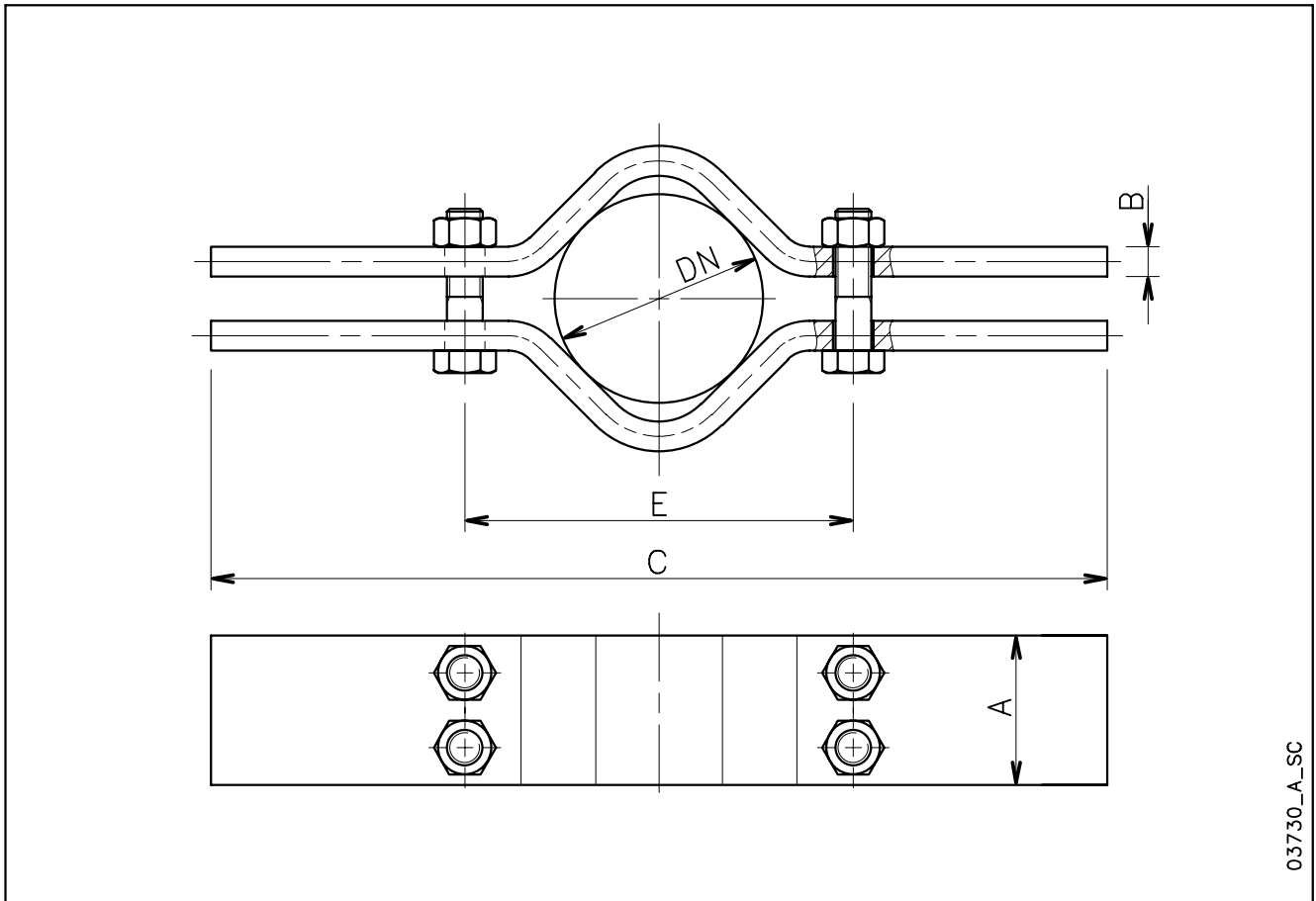

03730\_A\_SC

NOMINAL PIPE DIAMETER DN	CARRYING CLAMPS							PIPE WEIGHT		
	Dimensions (mm)						Pmax <sup>(1)</sup> kg	Flanged kg/m	Threaded kg/m	Water kg/m
	A	B	C	E	SCREW					
65	R 2 1/2"	50	15	600	130	M16x90	1300	6,7	8,0	3,3
80	R 3"	80	15	600	180	M20x70	3400	8,4	10,5	5,0
100	R 4"	80	15	600	180	M20x110	3400	20,5	15,0	7,9
125	R 5"	100	20	600	260	M24x90	7250	27,5	18,5	12,3
150	R 6"	100	20	600	260	M24x130	7250	33,0	22,0	17,6
175	R 7"	120	25	800	360	M30x110	9750	27,0	25,5	24,0
200	R 8"	120	25	800	360	M30x150	9750	33,0	34,0	31,5
250	R 10"	120	25	800	360	M30x220	9750	48,0	48,0	49,0

1) Max admissible weight.

clamp-en\_b\_td

NOTE: Two sets of clamps are necessary for the installation of one unit.

Material : EN 10027-1-S235JR (1.0038) painted.



## CP6W - CP8W MOTOR SERIES MOTOR - CONTROL PANEL COMBINATION TABLE

MOTOR TYPE CP6W - 6" THREE-PHASE	RATED POWER		RATED CURRENT 380-415 V A	PANEL TYPE					
	kW	HP		GQTD/...	GQ3D/...	GQ3I/...	GQ3A/...	GQ3Y/...	GQ3SF/...
	4	5,5	9,89	...40-75	...40-75	...40-75	...40-75	...40-75	...75
	5,5	7,5	12,7	...40-75	...40-75	...40-75	...40-75	...40-75	...75
	7,5	10	17,0	...75-92	...75-92	...75-92	...75-92	...75-92	...150
	9,3	12,5	20,5	-	...92-110	...92-110	...92-110	...92-110	...150
	11	15	24,2	-	...110-150	...110-150	...110-150	...110-150	...150
	13	17,5	28,1	-	...110-150	...110-150	...110-150	...110-150	...150
	15	20	32,1	-	...150-185	...150-185	...150-185	...150-185	...220
	18,5	25	38,5	-	...185-220	...185-220	...185-220	...185-220	...220
	22	30	47,3	-	...220-300	...220-300	...220-300	...220-300	...300
	26	35	56,5	-	...220-300	...220-300	...220-300	...220-300	...300
	30	40	63,8	-	...300-370	...300-370	...300-370	...300-370	...370
	37	50	81,8	-	...300-370	...300-370	...370-450	...370-450	...450
MOTOR TYPE CP6W HT - 6" THREE-PHASE	4	5,5	10,5	...40-75	...40-75	...40-75	...40-75	...40-75	...75
	5,5	7,5	13,4	...40-75	...40-75	...40-75	...40-75	...40-75	...75
	7,5	10	17,3	...75-92	...75-92	...75-92	...75-92	...75-92	...150
	9,3	12,5	20,8	-	...92-110	...92-110	...92-110	...92-110	...150
	11	15	23,9	-	...110-150	...110-150	...110-150	...110-150	...150
	13	17,5	28,4	-	...110-150	...110-150	...110-150	...110-150	...150
	15	20	32,5	-	...150-185	...150-185	...150-185	...150-185	...220
	18,5	25	41,6	-	...185-220	...185-220	...185-220	...185-220	...220
	22	30	49,7	-	...220-300	...220-300	...220-300	...220-300	...300
	26	35	55,8	-	...220-300	...220-300	...220-300	...220-300	...300
	30	40	68,8	-	...300-370	...300-370	...300-370	...300-370	...370

For different voltages, please contact our sales network.

cp6w-2p50-en\_c\_tc

MOTOR TYPE CP8W - 8" THREE-PHASE	RATED POWER		RATED CURRENT 380-415 V A	PANEL TYPE					
	kW	HP		GQ3D/...	GQ3I/...	GQ3A/...	GQ3SF/...		
	30	40	65	...300-370	...300-370	...300-370	...370		
	37	50	81	-	...370-450	...370-450	...450		
	45	60	92	-	...450-550	...450-550	...550		
	52	70	110	-	...550-750	...550-750	...590		
	55	75	118	-	...550-750	...550-750	...590		
	60	80	124	-	...550-750	...550-750	...750		
	67	90	138	-	...750-900	...750-900	...900		
	75	100	156	-	...750-900	...750-900	...900		
	83	110	172	-	...750-900	...750-900	...900		
	93	125	192	-	...900-1100	...900-1100	...1100		
MOTOR TYPE CP8W HT - 8" THREE-PHASE	30	40	66,6	...300-370	...300-370	...300-370	...370		
	37	50	77,5	-	...370-450	...370-450	...450		
	45	60	97,8	-	...450-550	...450-550	...550		
	52	70	110	-	...550-750	...550-750	...590		
	55	75	117	-	...550-750	...550-750	...590		
	60	80	127	-	...550-750	...550-750	...750		
	67	90	141	-	...750-900	...750-900	...900		
	75	100	156	-	...750-900	...750-900	...900		
	83	110	171	-	...750-900	...750-900	...900		

For different voltages, please contact our sales network.

cp8w-2p50-en\_c\_tc

## CP10W - CP12W MOTOR SERIES MOTOR - CONTROL PANEL COMBINATION TABLE

MOTOR TYPE CP10W - 10" THREE-PHASE	RATED POWER		RATED CURRENT 380-415 V A	PANEL TYPE					
	kW	HP		GQ3I/...	GQ3A/...	GQ3SF/...			
	93	125	191	...900-1100	...900-1100	...1100			
	110	150	235	...1100-1320	...1100-1320	...1100			
	130	175	270	...1320-1600	...1320-1600	(1)			
	150	200	308	...1600-2000	...1600-2000	(1)			
<b>MOTOR TYPE</b>	83	110	170,2	...750-900	...750-900	...900			
<b>CP10W HT - 10"</b>	93	125	200,5	...900-1100	...900-1100	...1100			
<b>THREE-PHASE</b>	110	150	233,0	...1100-1320	...1100-1320	...1100			
	130	175	288,0	...1320-1600	...1320-1600	(1)			

(1) On request.

cp10w-2p50-en\_c\_tc

For different voltages, please contact our sales network.

MOTOR TYPE CP12W - 12" THREE-PHASE	RATED POWER		RATED CURRENT 380-415 V A	PANEL TYPE					
	kW	HP		GQ3I/...	GQ3A/...	GQ3SF/...			
	185	250	380	...1600-2000	...1600-2000	(1)			
	220	300	470	...2500-3150	...2500-3150	(1)			
	260	350	525	...2500-3150	...2500-3150	(1)			
	300	400	620	(1)	(1)	(1)			
<b>MOTOR TYPE</b>	150	200	328,6	...1600-2000	...1600-2000	(1)			
<b>CP12W HT - 12"</b>	185	250	379,3	...1600-2000	...1600-2000	(1)			
<b>THREE-PHASE</b>	220	300	438,9	...2000-2500	...2000-2500	(1)			
	260	350	546,0	...2500-3150	...2500-3150	(1)			

(1) On request.

cp12w-2p50-en\_c\_tc

For different voltages, please contact our sales network.

## Three-phase Electric Panel

### APPLICATIONS

- Protection and control of a three-phase surface or submersible electric pump.

## GQTD Series



### SPECIFICATIONS

- Control through an external enable contact.
- Supply voltage: 3 x 400 V  $\pm$  10%.
- Frequency: 50/60 Hz.
- Power: 0,25 to 9,2 kW.
- Direct motor start.
- Short-circuit and overload protection.
- Protection class: IP54.
- Ambient temperature: -5 to +40 °C (according to EN 60439-1).
- Maximum relative humidity: 50% at +40°C, provided that no condensation occurs (according to EN 60439-1).
- Wall mounted.
- Metal enclosure.
- Ready for installation of dry running control float or pressure switch (to be ordered separately).
- Power and thermal overload indicator lights.

### OPTIONAL ACCESSORIES

- VR3 three-phase module for overvoltage protection (lightning protector).
- KSL series 24 V level kit. Probe module for protection against dry running (set of three electrodes included in the supply).

### SELECTION

- For a suitable choice of control panel, be sure the electrical input of the motor (Ampere) is included in the rated current value mentioned in the table below.

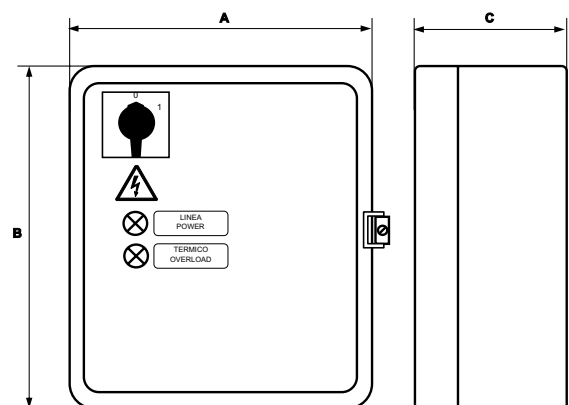

MODEL	RATED VOLTAGE V	RATED POWER		RATED CURRENT A	DIMENSIONS			WEIGHT Kg
		kW	HP		A mm	B mm	C mm	
GQTD/02-03	3 x 400 V $\pm$ 10 %	0,25-0,37	0,33-0,50	0,63 $\div$ 1	235	265	150	5,8
GQTD/03-05	3 x 400 V $\pm$ 10 %	0,37-0,55	0,55-0,75	1 $\div$ 1,6	235	265	150	5,8
GQTD/05-07	3 x 400 V $\pm$ 10 %	0,55-0,75	0,75-1	1,6 2,5	235	265	150	5,8
GQTD/07-15	3 x 400 V $\pm$ 10 %	0,75-1,5	1-2	2,5 4	235	265	150	5,8
GQTD/15-22	3 x 400 V $\pm$ 10 %	1,5-2,2	2-3	4 $\div$ 6,3	235	265	150	5,8
GQTD/22-40	3 x 400 V $\pm$ 10 %	2,2-4	3-5,5	6,3 $\div$ 10	235	265	150	5,8
GQTD/40-75	3 x 400 V $\pm$ 10 %	4-7,5	5,5-10	10 $\div$ 16	235	265	150	5,8
GQTD/75-92	3 x 400 V $\pm$ 10 %	7,5-9,2	10-12,5	16 $\div$ 20	235	265	150	5,8

## Three-phase Electric Panel

### APPLICATIONS

- Protection and control of a three-phase surface or submersible electric pump.

## GQ3D Series



### SPECIFICATIONS

- Manual control through an Auto/Man selector switch.
- Automatic control through an external enable contact.
- Supply voltage: 3 x 400 V  $\pm$  10%.
- Frequency: 50/60 Hz.
- 24 V AC low voltage auxiliary circuit.
- Power: 0,25 to 37 kW.
- Direct motor start.
- Short-circuit and overload protection.
- Protection class: IP54.
- Ambient temperature: -5 to +40 °C (according to EN 60439-1).
- Maximum relative humidity: 50% at +40°C, provided that no condensation occurs (according to EN 60439-1).
- Wall mounted.
- Metal enclosure.
- Power, pump running, thermal overload and dry running indicator lights.

- Ready for installation of dry running control float or pressure switch (to be ordered separately). Can be equipped with electronic protection module with electrodes.

### OPTIONAL ACCESSORIES

- KSL series 24 V level kit. Probe module for protection against dry running (set of three electrodes included in the supply).
- Float.
- Pressure switch.
- VR3 three-phase module for overvoltage protection (lightning protector).

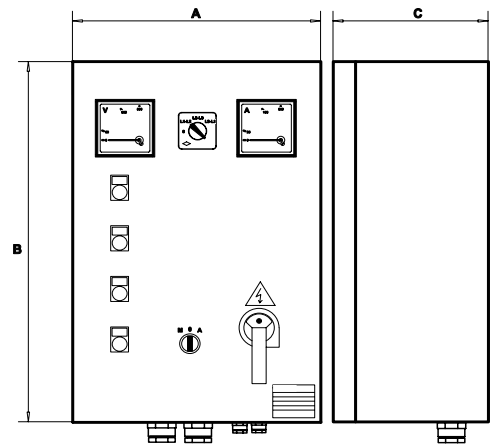

MODEL	RATED VOLTAGE V	RATED POWER		RATED CURRENT A	DIMENSIONS			WEIGHT Kg
		kW	HP		A mm	B mm	C mm	
GQ3D/02-03	3 x 400 V $\pm$ 10 %	0,25-0,37	0,33-0,50	0,63 $\div$ 1	300	400	200	15
GQ3D/03-05	3 x 400 V $\pm$ 10 %	0,37-0,55	0,5-0,75	1 $\div$ 1,6	300	400	200	15
GQ3D/05-07	3 x 400 V $\pm$ 10 %	0,55-0,75	0,75-1	1,6 $\div$ 2,5	300	400	200	15
GQ3D/07-15	3 x 400 V $\pm$ 10 %	0,75-1,5	1-2	2,5 $\div$ 4	300	400	200	15
GQ3D/15-22	3 x 400 V $\pm$ 10 %	1,5-2,2	2-3	4 $\div$ 6,3	300	400	200	15
GQ3D/22-40	3 x 400 V $\pm$ 10 %	2,2-4	3-5,5	6,3 $\div$ 10	300	400	200	15
GQ3D/40-75	3 x 400 V $\pm$ 10 %	4-7,5	5,5-10	10 $\div$ 16	300	400	200	15
GQ3D/75-92	3 x 400 V $\pm$ 10 %	7,5-9,2	10-12,5	16 $\div$ 20	300	400	200	15
GQ3D/92-110	3 x 400 V $\pm$ 10 %	9,2-11	12,5-15	20 $\div$ 25	300	400	200	20
GQ3D/110-150	3 x 400 V $\pm$ 10 %	11-15	15-20	22 $\div$ 32	400	500	200	20
GQ3D/150-185	3 x 400 V $\pm$ 10 %	15-18,5	20-25	28 $\div$ 40	400	500	200	20
GQ3D/185-220	3 x 400 V $\pm$ 10 %	18,5-22	25-30	36 $\div$ 50	400	600	200	27
GQ3D/220-300	3 x 400 V $\pm$ 10 %	22-30	30-40	45 $\div$ 63	400	600	200	27
GQ3D/300-370	3 x 400 V $\pm$ 10 %	30-37	40-50	57 $\div$ 75	400	600	200	27

## Three-phase Electric Panel

### GQ3Y Series



### APPLICATIONS

- Protection and control of a three-phase surface or submersible electric pump.

### SPECIFICATIONS

- Manual control through an Auto/Man selector switch.
- Automatic control through an external enable contact.
- Supply voltage: 3 x 400 V  $\pm$  10%.
- Frequency: 50/60 Hz.
- 24 V AC low voltage auxiliary circuit.
- Power: 4 to 315 kW.
- Star-delta starting.
- Short-circuit and overload protection.
- Protection class: IP54.
- Ambient temperature: -5 to +40 °C (according to EN 60439-1).
- Maximum relative humidity: 50% at +40°C, provided that no condensation occurs (according to EN 60439-1).
- Wall mounted.
- Metal enclosure.
- Power, pump running, thermal overload and dry running indicator lights.

- Ready for installation of dry running control float or pressure switch (to be ordered separately). Can be equipped with electronic protection module with electrodes.

### OPTIONAL ACCESSORIES

- KSL series 24 V level kit. Probe module for protection against dry running (set of three electrodes included in the supply).
- Float.
- Pressure switch.
- VR3 three-phase module for overvoltage protection (lightning protector).

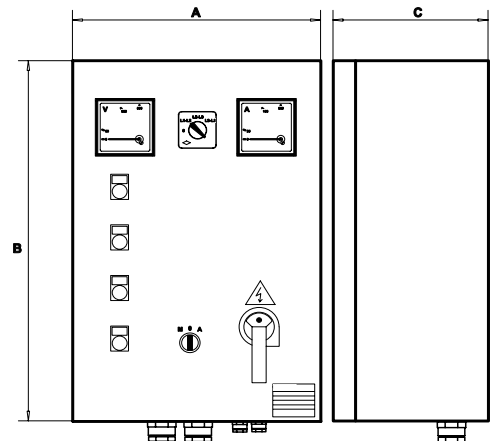

MODEL	RATED VOLTAGE V	RATED POWER		RATED CURRENT A	DIMENSIONS			WEIGHT Kg
		kW	HP		A mm	B mm	C mm	
GQ3Y/40-75	3 x 400 V $\pm$ 10 %	4-7,5	5,5-10	10 $\div$ 16	400	600	200	23
GQ3Y/75-92	3 x 400 V $\pm$ 10 %	7,5-9,2	10-12,5	16 $\div$ 20	400	600	200	23
GQ3Y/92-110	3 x 400 V $\pm$ 10 %	9,2-11	12,5-15	20 $\div$ 25	400	600	200	23
GQ3Y/110-150	3 x 400 V $\pm$ 10 %	11-15	15-20	22 $\div$ 32	400	600	200	23
GQ3Y/150-185	3 x 400 V $\pm$ 10 %	15-18,5	20-25	28 $\div$ 40	400	600	200	23
GQ3Y/185-220	3 x 400 V $\pm$ 10 %	18,5-22	25-30	36 $\div$ 50	500	700	200	32
GQ3Y/220-300	3 x 400 V $\pm$ 10 %	22-30	30-40	45 $\div$ 63	500	700	200	32
GQ3Y/300-370	3 x 400 V $\pm$ 10 %	30-37	40-50	57 $\div$ 75	600	800	250	68
GQ3Y/370-450	3 x 400 V $\pm$ 10 %	37-45	50-60	70 $\div$ 90	600	800	250	80
GQ3Y/450-550	3 x 400 V $\pm$ 10 %	45-55	60-75	80 $\div$ 108	600	900	250	80
GQ3Y/550-750	3 x 400 V $\pm$ 10 %	55-75	75-100	105 $\div$ 138	600p	1300p	300p	109
GQ3Y/750-900	3 x 400 V $\pm$ 10 %	75-90	100-125	138 $\div$ 185	600p	1300p	300p	109
GQ3Y/900-1100	3 x 400 V $\pm$ 10 %	90-110	125-150	175 $\div$ 210	600p	1500p	300p	120
GQ3Y/1100-1320	3 x 400 V $\pm$ 10 %	110-132	150-180	210 $\div$ 260	800p	1700p	400p	130
GQ3Y/1320-1600	3 x 400 V $\pm$ 10 %	132-160	180-218	250 $\div$ 305	800p	1700p	400p	130
GQ3Y/1600-2000	3 x 400 V $\pm$ 10 %	160-200	218-273	290 $\div$ 400	800p	1900p	400p	140
GQ3Y/2000-2500	3 x 400 V $\pm$ 10 %	200-250	273-340	400 $\div$ 460	1000p	1900p	400p	180
GQ3Y/2500-3150	3 x 400 V $\pm$ 10 %	250-315	340-430	450 $\div$ 580	1000p	1900p	400p	180

Dimensions note : P indicates floor mounted control panel.

CB-GQ3Y-en\_c\_te

## Three-phase Electric Panel

### GQ3I Series



### APPLICATIONS

- Protection and control of a three-phase surface or submersible electric pump.

### SPECIFICATIONS

- Manual control through an Auto/Man selector switch.
- Automatic control through an external enable contact.
- Supply voltage: 3 x 400 V ± 10%.
- Frequency: 50/60 Hz.
- 24 V AC low voltage auxiliary circuit.
- Power: 4 to 315 kW.
- Impedance start.
- Short-circuit and overload protection.
- Protection class: IP54.
- Ambient temperature: -5 to +40 °C (according to EN 60439-1).
- Maximum relative humidity: 50% at +40°C, provided that no condensation occurs (according to EN 60439-1).
- Wall mounted.
- Metal enclosure.
- Power, pump running, thermal overload and dry running indicator lights.

- Ready for installation of dry running control float or pressure switch (to be ordered separately). Can be equipped with electronic protection module with electrodes.

### OPTIONAL ACCESSORIES

- KSL series 24 V level kit. Probe module for protection against dry running (set of three electrodes included in the supply).
- Float.
- Pressure switch.
- VR3 three-phase module for overvoltage protection (lightning protector).

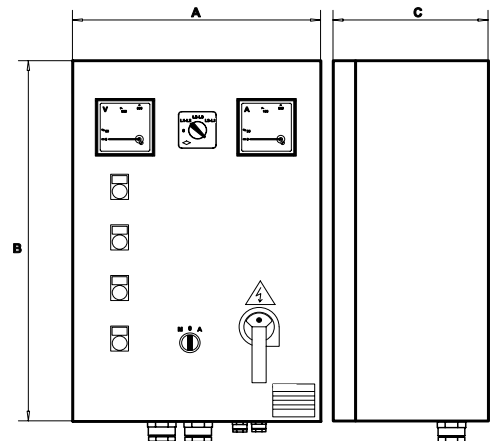

MODEL	RATED VOLTAGE V	RATED POWER		RATED CURRENT A	DIMENSIONS			WEIGHT Kg
		kW	HP		A mm	B mm	C mm	
GQ3I/40-75	3 x 400 V ± 10 %	4-7,5	5,5-10	10 ÷ 16	400	600	250	35
GQ3I/75-92	3 x 400 V ± 10 %	7,5-9,2	10-12,5	16 ÷ 20	400	600	250	35
GQ3I/92-110	3 x 400 V ± 10 %	9,2-11	12,5-15	20 ÷ 25	400	600	250	35
GQ3I/110-150	3 x 400 V ± 10 %	11-15	15-20	22 ÷ 32	500	700	250	50
GQ3I/150-185	3 x 400 V ± 10 %	15-18,5	20-25	28 ÷ 40	500	700	250	50
GQ3I/185-220	3 x 400 V ± 10 %	18,5-22	25-30	36 ÷ 50	500	700	250	50
GQ3I/220-300	3 x 400 V ± 10 %	22-30	30-40	45 ÷ 63	500	700	250	65
GQ3I/300-370	3 x 400 V ± 10 %	30-37	40-50	57 ÷ 75	500	700	250	65
GQ3I/370-450	3 x 400 V ± 10 %	37-45	50-60	70 ÷ 90	600	900	250	65
GQ3I/450-550	3 x 400 V ± 10 %	45-55	60-75	80 ÷ 108	600p	1300p	300p	100
GQ3I/550-750	3 x 400 V ± 10 %	55-75	75-100	105 ÷ 138	600p	1300p	300p	100
GQ3I/750-900	3 x 400 V ± 10 %	75-90	100-125	138 ÷ 185	600p	1500p	300p	100
GQ3I/900-1100	3 x 400 V ± 10 %	90-110	125-150	175 ÷ 210	800p	1700p	400p	100
GQ3I/1100-1320	3 x 400 V ± 10 %	110-132	150-180	210 ÷ 260	800p	1700p	400p	150
GQ3I/1320-1600	3 x 400 V ± 10 %	132-160	180-218	250 ÷ 305	800p	1700p	400p	150
GQ3I/1600-2000	3 x 400 V ± 10 %	160-200	218-273	290 ÷ 400	800p	1900p	400p	160
GQ3I/2000-2500	3 x 400 V ± 10 %	200-250	273-340	400 ÷ 460	1000p	1900p	400p	180
GQ3I/2500-3150	3 x 400 V ± 10 %	250-315	340-430	450 ÷ 580	1000p	1900p	400p	200

Dimensions note : P indicates floor mounted control panel.

CB-GQ3I-en\_c\_te

## Three-phase Electric Panel

### GQ3A Series



### APPLICATIONS

- Protection and control of a three-phase surface or submersible electric pump.

### SPECIFICATIONS

- Manual control through an Auto/Man selector switch.
- Automatic control through an external enable contact.
- Supply voltage: 3 x 400 V ± 10%.
- Frequency: 50/60 Hz.
- 24 V AC low voltage auxiliary circuit.
- Power: 4 to 315 kW.
- Starting autotransformer.
- Short-circuit and overload protection.
- Protection class: IP54.
- Ambient temperature: -5 to +40 °C (according to EN 60439-1).
- Maximum relative humidity: 50% at +40°C, provided that no condensation occurs (according to EN 60439-1).
- Wall mounted.
- Metal enclosure.
- Power, pump running, thermal overload and dry running indicator lights.

- Ready for installation of dry running control float or pressure switch (to be ordered separately). Can be equipped with electronic protection module with electrodes.

### OPTIONAL ACCESSORIES

- KSL series 24 V level kit. Probe module for protection against dry running (set of three electrodes included in the supply).
- Float.
- Pressure switch.
- VR3 three-phase module for overvoltage protection (lightning protector).

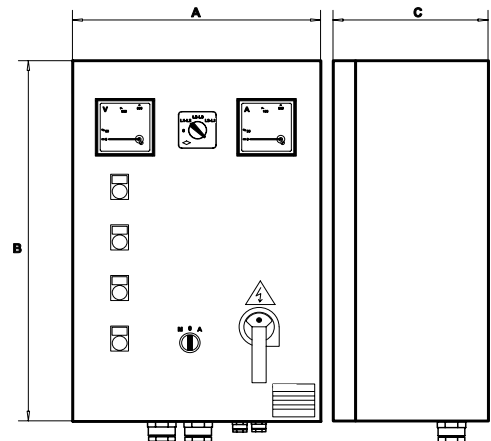

MODEL	RATED VOLTAGE V	RATED POWER		RATED CURRENT A	DIMENSIONS			WEIGHT Kg
		kW	HP		A mm	B mm	C mm	
GQ3A/40-75	3 x 400 V ± 10 %	4-7,5	5,5-10	10 ÷ 16	500	700	250	50
GQ3A/75-92	3 x 400 V ± 10 %	7,5-9,2	10-12,5	16 ÷ 20	500	700	250	50
GQ3A/92-110	3 x 400 V ± 10 %	9,2-11	12,5-15	20 ÷ 25	500	700	250	50
GQ3A/110-150	3 x 400 V ± 10 %	11-15	15-20	22 ÷ 32	500	700	250	50
GQ3A/150-185	3 x 400 V ± 10 %	15-18,5	20-25	28 ÷ 40	500	700	250	50
GQ3A/185-220	3 x 400 V ± 10 %	18,5-22	25-30	36 ÷ 50	500	700	250	50
GQ3A/220-300	3 x 400 V ± 10 %	22-30	30-40	45 ÷ 63	600	900	300	80
GQ3A/300-370	3 x 400 V ± 10 %	30-37	40-50	57 ÷ 75	600	900	300	80
GQ3A/370-450	3 x 400 V ± 10 %	37-45	50-60	70 ÷ 90	600p	1300p	300p	90
GQ3A/450-550	3 x 400 V ± 10 %	45-55	60-75	80 ÷ 108	600p	1500p	300p	120
GQ3A/550-750	3 x 400 V ± 10 %	55-75	75-100	105 ÷ 138	600p	1500p	300p	120
GQ3A/750-900	3 x 400 V ± 10 %	75-90	100-125	138 ÷ 185	600p	1700p	400p	150
GQ3A/900-1100	3 x 400 V ± 10 %	90-110	125-150	175 ÷ 210	800p	1900p	400p	150
GQ3A/1100-1320	3 x 400 V ± 10 %	110-132	150-180	210 ÷ 260	800p	1900p	400p	200
GQ3A/1320-1600	3 x 400 V ± 10 %	132-160	180-218	250 ÷ 305	800p	1900p	400p	200
GQ3A/1600-2000	3 x 400 V ± 10 %	160-200	218-273	290 ÷ 400	800p	1900p	400p	230
GQ3A/2000-2500	3 x 400 V ± 10 %	200-250	273-340	400 ÷ 460	1000p	1900p	400p	230
GQ3A/2500-3150	3 x 400 V ± 10 %	250-315	340-430	450 ÷ 580	1000p	1900p	400p	250

Dimensions note : P indicates floor mounted control panel.

CB-GQ3A-en\_c\_te

## Three-phase Electric Panel

### GQ3SF Series



#### APPLICATIONS

- Protection and control of a three-phase surface or submersible electric pump.

#### SPECIFICATIONS

- Manual control through an Auto/Man selector switch.
- Automatic control through an external enable contact.
- Supply voltage: 3 x 400 V  $\pm$  10%.
- Frequency: 50/60 Hz.
- 24 V AC low voltage auxiliary circuit.
- Power: 5,5 to 110 kW.
- Softstart with torque control.
- Protection class: IP54.
- Ambient temperature: -5 to +40 °C
- Maximum relative humidity: 50% at +40°C, provided that no condensation occurs (according to EN 60439-1).
- Wall mounted.
- Metal enclosure.
- Dry running indicator light.
- Power - pump running - malfunction LEDs on starter keypad.
- ON/OFF selector switch for activation of by-pass contactor.
- Ready for installation of dry running control float or pressure switch (to be ordered separately). Can be equipped with electronic protection module with electrodes.

Protections against phase failure / phase sequence / frequency out of limits on power supply line.  
Low-voltage protection on auxiliary circuits.  
Protection against starter overtemperature / overload / malfunction.  
Protection against overload / locked rotor / current asymmetry on motor side.  
Short-circuit protection on inputs and outputs.  
RS232 interface for remote control and RS485 for use of remote keypad.  
Incorporated by-pass contactor.

#### OPTIONAL ACCESSORIES

- KSL series 24 V level kit. Probe module for protection against dry running (set of three electrodes included in the supply).
- Float.
- Pressure switch.
- VR3 three-phase module for overvoltage protection (lightning protector).

#### STATIC STARTER CHARACTERISTICS

- Static starter for gradual start-up/shutdown, featuring: keypad with liquid crystal display showing voltage, absorbed current,  $\cos \Phi$ , operating hours, number of starts, last twenty messages on system status (events / alarms).

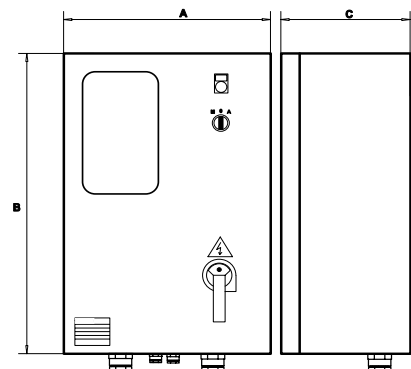

MODEL	RATED VOLTAGE V	RATED POWER		RATED CURRENT A	DIMENSIONS			WEIGHT Kg
		kW	HP		A mm	B mm	C mm	
GQ3SF 75	3 x 400 V $\pm$ 10 %	5,5 - 7,5	7,5 - 10	8,5 $\div$ 17	400	600	250	35
GQ3SF 150	3 x 400 V $\pm$ 10 %	9,2 - 15	12,5 - 20	15 $\div$ 30	500	700	250	40
GQ3SF 220	3 x 400 V $\pm$ 10 %	18,5 - 22	25 - 30	28 $\div$ 45	500	700	250	40
GQ3SF 300	3 x 400 V $\pm$ 10 %	30	40	42 $\div$ 60	600	900	300	90
GQ3SF 370	3 x 400 V $\pm$ 10 %	37	50	55 $\div$ 75	600	900	300	90
GQ3SF 450	3 x 400 V $\pm$ 10 %	45	60	70 $\div$ 85	600	900	300	90
GQ3SF 550	3 x 400 V $\pm$ 10 %	55	75	80 $\div$ 110	600	900	300	90
GQ3SF 590	3 x 400 V $\pm$ 10 %	59	80	105 $\div$ 125	600	900	300	90
GQ3SF 750	3 x 400 V $\pm$ 10 %	75	100	120 $\div$ 142	600p	1700p	400p	120
GQ3SF 900	3 x 400 V $\pm$ 10 %	90	125	135 $\div$ 190	600p	1700p	400p	120
GQ3SF 1100	3 x 400 V $\pm$ 10 %	110	150	185 $\div$ 245	600p	1700p	400p	120

Dimensions note : P indicates floor mounted control panel.

CB-GQ3SF-en\_b\_te



## Level Control Panel

### APPLICATIONS

- Accessory for electric pump control panels, suitable for tank filling or drainage applications or for activation of audible or visual alarms.

### GQCL5 Series



### SPECIFICATIONS

- Automatic control through probes.
- Supply voltage:  
1 x 230 V  $\pm$ 10% or 1 x 24 V  $\pm$ 10%.
- Frequency: 50/60 Hz.
- Voltage to probes:  
15 V AC at 0,5 mA max.
- Switch contact 48 V AC at 3 A max (250 W max).
- Protection class: IP55.
- Ambient temperature: -5 to +40 °C (according to EN 60439-1).
- Maximum relative humidity: 50% at +40°C, provided that no condensation occurs (according to EN 60439-1).
- Wall mounted.
- Plastic enclosure.
- Electrodes suitable for water at a maximum temperature of 40°C.
- Set of three electrodes included in the supply.

### OPTIONAL ACCESSORIES

- Drop cable with circular cross section.

For connection of the electrodes to the panel we recommend the following cross sections:

LENGHT m		CABLE SECTION mm <sup>2</sup>
0	50	0,5
50	100	0,75
100	200	1,0
200	400	2,5

CB-CASEL-en\_b\_te

Three-pole cables can be used for short lengths.

Otherwise we recommend the use of unipolar cables placed at suitable distance from each other to prevent the capacitive effect of the cable from interfering with the proper operation of the electronic module.

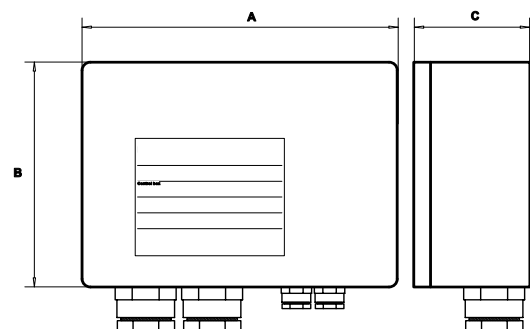

TYPE	POWER SUPPLY			CONTACT			DIMENSIONS A x B x C mm	WEIGHT Kg
	VOLTAGE V	FREQUENCY Hz	POWER W	TYPE	RANGE V	A		
GQCL5/24	1 x 24	50/60	2	NO-C-NC	48	3	90 x 130 x 60	0,5
GQCL5/230	1 x 230	50/60	2					

CB-GQCL5-en\_a\_te

## Kit 24 V Level Probe

### APPLICATIONS

- Accessory for electric panels.

## KSL Series



### SPECIFICATIONS

- Electronic module for use of probes as protection against dry running.
- Supply voltage:  
1 x 24 V  $\pm$  10% for model SLD/24.
- Frequency: 50/60 Hz.
- Absorbed power: 3,5 VA max.
- Voltage to probes:  
7,5 V AC at 0,4 mA max.
- Switch contact 24 V AC at 5 A max (250 W max).
- Designed for installation on GOULDS electric panels featuring DIN bar.
- Electrodes suitable for water at a maximum temperature of 60°C.

### CONSTRUCTION CHARACTERISTICS

- Module made of plastic material with DIN bar attachment.
- Cables with quick plug-in connectors.
- Set of three electrodes included in the supply.
- Electrodes with nylon 6 body, stainless steel sensitive element brass washer and nitrile rubber seal.

### OPTIONAL ACCESSORIES

- Drop cable with circular cross section.

For connection of the electrodes to the panel we recommend the following cross sections:

LENGHT m		CABLE SECTION mm <sup>2</sup>
0	50	0,5
50	100	0,75
100	200	1,0
200	400	2,5

CB-CASEL-en\_b\_te

Three-pole cables can be used for short lengths.

Otherwise we recommend the use of unipolar cables placed at suitable distance from each other to prevent the capacitive effect of the cable from interfering with the proper operation of the electronic module.

TYPE	POWER SUPPLY		CONTACT			DIMENSIONS A x B x C mm	WEIGHT Kg	PANELS	
	MAIN V	POWER VA	TYPE	RANGE V~ A					
KIT KSL/24	1x24	50/60 Hz	3,5	N0-C-NC	250	8	90 x 36 x 60	0,5	GQSCS-GQM-GQTD-GQ3D-GQ3Y-GQ3A-GQ3I-GQ3SF

CB-GSLD-en\_b\_te

## Lightning Protection

### APPLICATIONS

- Accessory for electric panels.

## DPF Series



### SPECIFICATIONS

- Varistor for overvoltage protection of single-phase lines. To be connected between the phase and neutral conductor.
- Operating voltage: 460 V AC.
- Maximum varistor voltage: 750 V with 100 A peak current.

## VR Series



### SPECIFICATIONS

- Varistors for overvoltage protection of three-phase lines.
- To be connected between the phases (VR3 model).
- Operating voltage: 460 V AC.
- Maximum varistor voltage: 750 V with 100 A peak current.
- Designed for installation on GOULDS electric panels featuring DIN bar.

TYPE	VOLTAGE V	PANELS
DPF	1 x 220-240 50/60 Hz	GQSM - GQSC - GQSCS - GQPC
KIT VR1	1 x 220-230 50/60 Hz	GQM - GQDRM - GQDRM2 - GQDRMC - GQDRMC2
KIT VR3	3 x 400 50/60 Hz	GQTD - GQDR - GQDR2 - GQ3D

CB-GVR-en\_d\_te

## COOLING SHROUDS

01890\_B\_DD

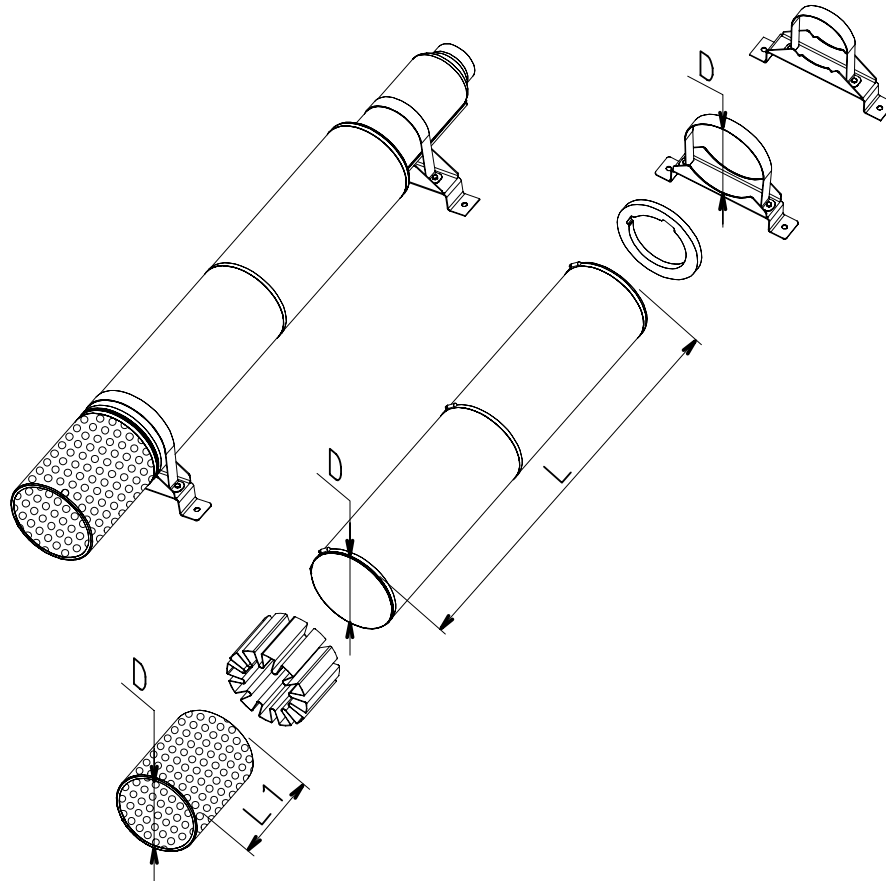

## COOLING SHROUDS GZ10-GZ12 PUMP SERIES 6", 8", 10" and 12" MOTORS COMBINATION TABLE

PUMP TYPE	MOTOR TYPE					COOLING SET SHROUD (D x L)	COOLING SET FILTER (D x L1)	COOLING SET BRACKETS (D)
	CP6C	CP6W	CP8W	CP10W	CP12W			
GZ10150	11	11				D285X1000	D285X325	D285 - 2PZ
	-	13						
GZ10150 GZ10220	15	15				D285X1000	D285X325	D285 - 2PZ
	18,5	18,5						
	22	22				D285X1250	D285X325	D285 - 2PZ
	-	26						
	30	-						
	-	30				D285X1500	D285X385	D285 - 3PZ
GZ10275	18,5	18,5				D330X1250	D330X385	D330 - 2PZ
	22	22						
	-	26						
	30	-						
	-	30				D330X1500	D330X385	D330 - 3PZ
GZ10150 GZ10220	37	37						
			30			D330X1250	D330X385	D330 - 2PZ
			37					
			45					
			52			D330X1500	D330X385	D330 - 3PZ
			55					
			60					
			67					
			75			D330X1750	D330X385	D330 - 3PZ
			83					
GZ10275 GZ12340			93			D330X2000	D330X385	D330 - 3PZ
			30			D380X1250	D380X385	D380 - 2PZ
			37					
			45					
			52			D380X1500	D380X385	D380 - 3PZ
			55					
			60					
			67					
			75			D380X1750	D380X385	D380 - 3PZ
			83					
GZ12420			93			D380X2000	D380X385	D380 - 3PZ
			30			D420X1250	D420X385	D420 - 2PZ
			37					
			45					
			52			D420X1500	D420X385	D420 - 3PZ
			55					
			60					
			67					
			75			D420X1750	D420X385	D420 - 3PZ
GZ10150 GZ10220 GZ10275 GZ12340 GZ12420			83					
			93			D420X2000	D420X385	D420 - 3PZ
			30			D330X2000	D330X385	D330 - 3PZ
			37					
			45					
			52			D330X2250	D330X385	D330 - 3PZ
			55					
			60			D380X2000	D380X385	D380 - 3PZ
			67					
			75			D380X2250	D380X385	D380 - 3PZ
GZ12340			83			D420X2000	D420X385	D420 - 3PZ
			93					
			110			D420X2250	D420X385	D420 - 3PZ
			130			D450X2000	D450X385	D450 - 3PZ
GZ12420			150			D450X2250	D450X385	D450 - 3PZ
			185			D380X2000	D380X385	D380 - 3PZ
			220			D380X2250	D380X385	D380 - 3PZ
			260			D380X2500	D380X385	D380 - 3PZ
GZ10275			300			D420X2000	D420X385	D420 - 3PZ
			185			D420X2250	D420X385	D420 - 3PZ
			220			D420X2500	D420X385	D420 - 3PZ
			260			D420X2250	D420X385	D420 - 3PZ
GZ12340			300			D450X2000	D450X385	D450 - 3PZ
			185			D450X2250	D450X385	D450 - 3PZ
			220			D450X2500	D450X385	D450 - 3PZ
			260			D450X2250	D450X385	D450 - 3PZ
GZ12420			300			D480X2000	D480X385	D480 - 3PZ
			185			D480X2250	D480X385	D480 - 3PZ
			220			D480X2500	D480X385	D480 - 3PZ
			260			D480X2250	D480X385	D480 - 3PZ

Material : Stainless steel EN 10088-1 - X5CrNi18-10 (1.4301) AISI 304. (Other materials available on request).

GZ10-GZ12\_kit-raf50-en\_b\_ta

**BOOSTER SHROUD**

Pressure shroud on request

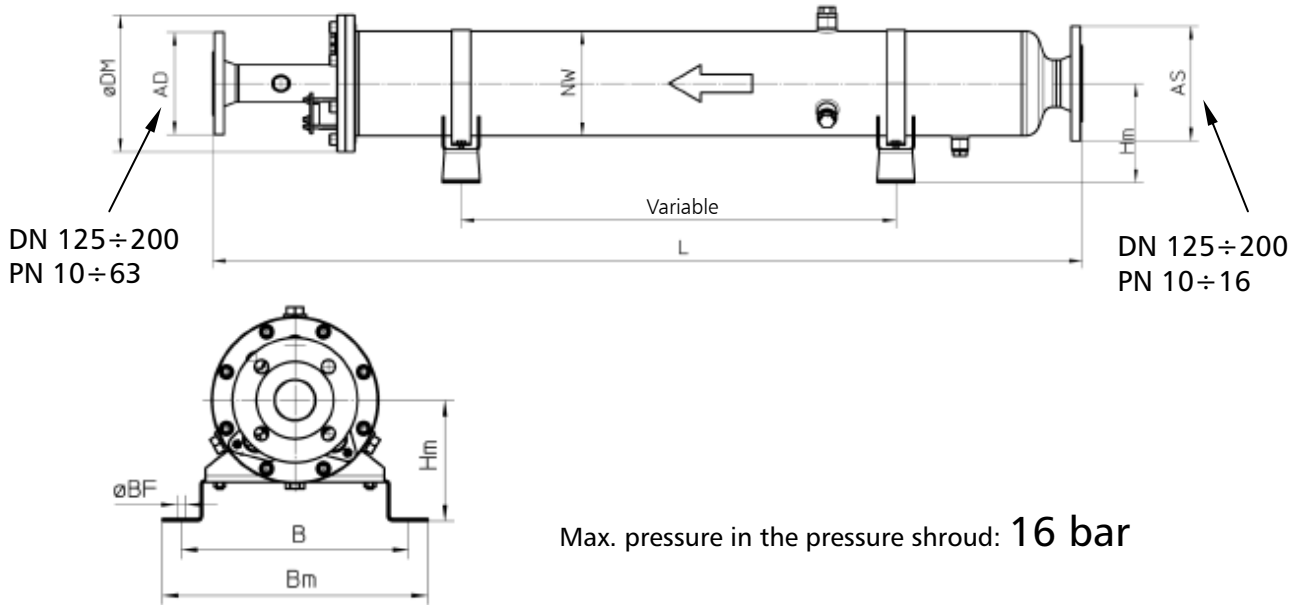

# **TECHNICAL APPENDIX**

## SUBMERSIBLE ELECTRIC PUMP INSTALLATION DIAGRAM

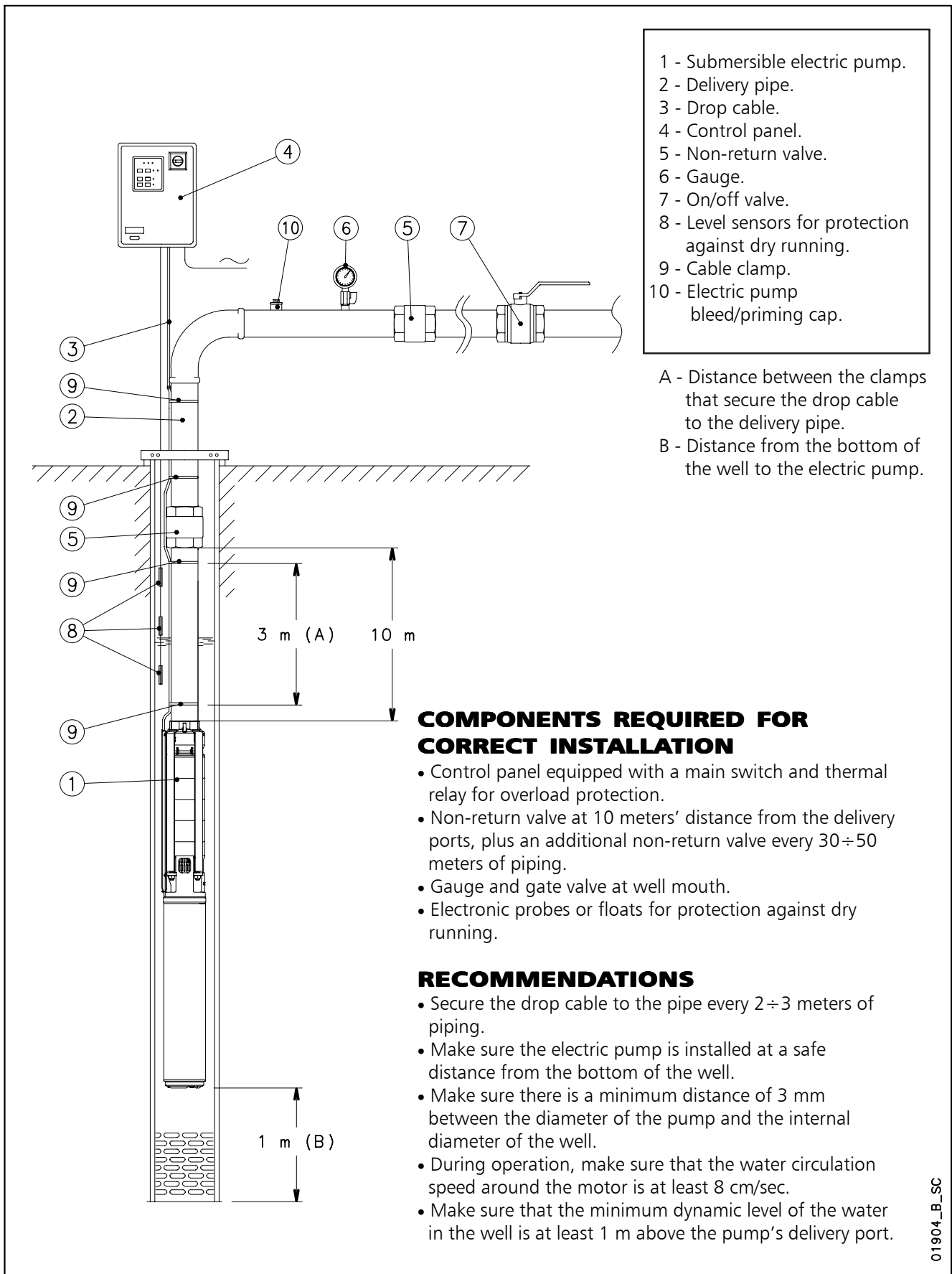

01904\_B\_SC



**EXAMPLE OF INSTALLATION OF A SUBMERSIBLE ELECTRIC PUMP CONTROLLED BY AN INVERTER (HYDROVAR®)**

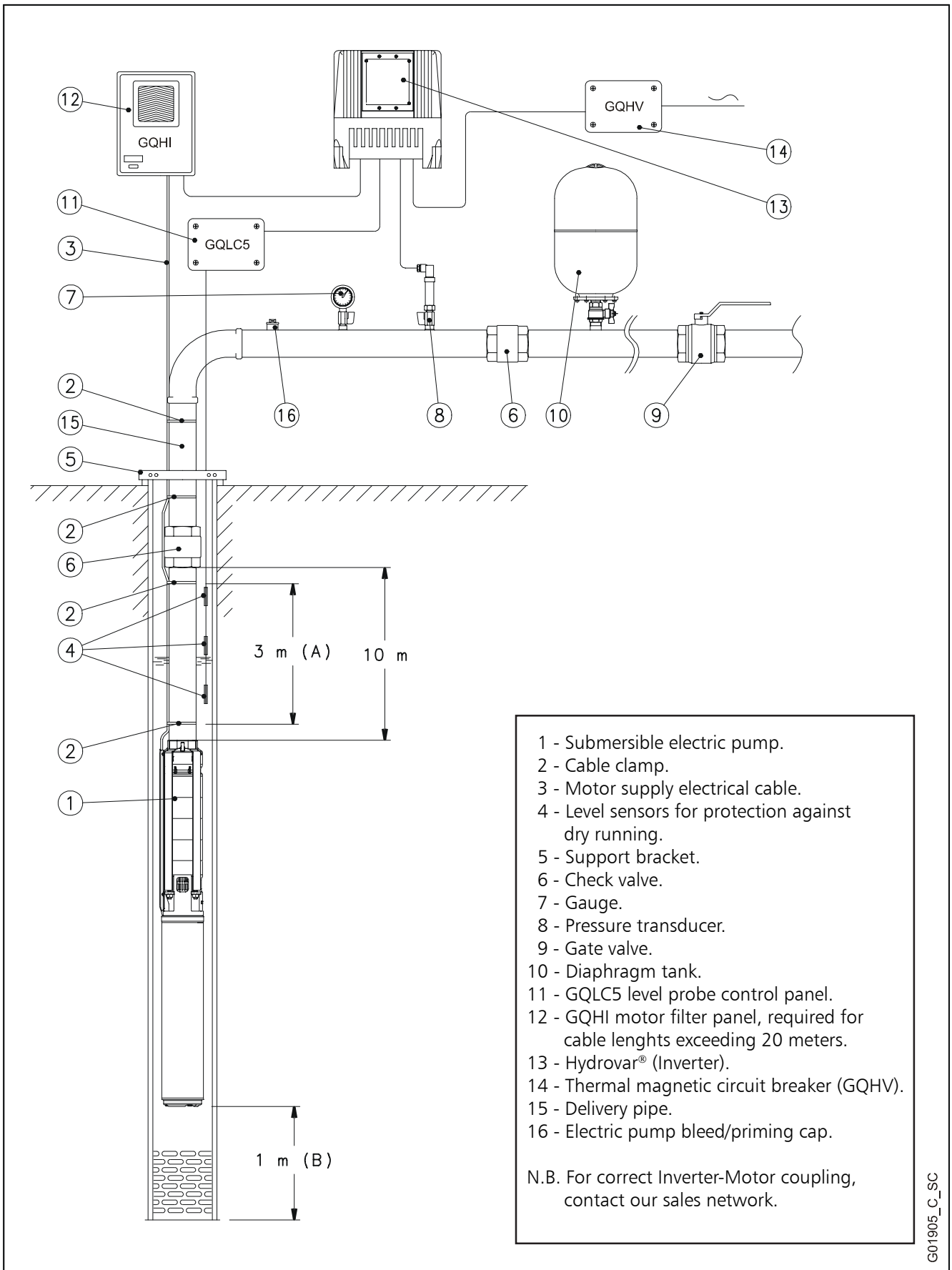

## CP6W - CP8W - CP10W MOTOR SERIES

TABLE OF POWER REDUCTION COEFFICIENTS WITH INCREASED WATER TEMPERATURE

MOTOR TYPE	RATED POWER kW	TEMPERATURE °C							
		25	30	35	40	45	50	55	60
STD	all models	1	1	0,75	-	-	-	-	-
HT	all models	1	1	1	1	1	0,85	0,75	0,65

(1) Standard winding for water temperature up to 35 °C.

Lw-derating-en\_a\_te

(2) Special winding for water temperature from 35 °C to 60 °C.

### EXAMPLE:

A 15 kW CP6W motor is to be used in 35°C water.

Motor power at 35 °C = 15 x 0,75 = 11,25 kW

## SELECTING CABLE CROSS-SECTIONS FOR SUBMERSIBLE MOTORS

To select the cross-section of power cables for submersible pumps, consult the tables shown below. In these tables, the maximum lengths of the power cable for each cross-section are shown for each motor and next to the various input voltage ratings.

Therefore, to find the required cable cross-section, simply read off the maximum permitted lengths for each cross-section next to the selected motor and required input voltage.

E.g.:

A 120 m long power cable must be matched with a 230V CP4C07M235 motor.

To determine the cross-section of the cable, simply move along the row of the 230V motor until you find the maximum length of 120 m or immediately above it and then read off the corresponding cross-section in that column.

In this case, the 4 mm<sup>2</sup> cable is selected.

N.B.: the tables include specific data (current and power factor) for each motor and voltage rating based on a maximum voltage drop of 4% (HD 384.5), a maximum cable temperature of 90°C, water installation similar to air installation at a temperature of 30°C.

## CABLE TYPES

SECTION mm <sup>2</sup>	THREE CORE FLAT					FOUR CORE FLAT					SINGLE CORE ROUND			FOUR CORE ROUND		
	Hmin mm	Lmin mm	Hmax mm	Lmax mm	Weight kg/km	Hmin mm	Lmin mm	Hmax mm	Lmax mm	Weight kg/km	Dmin mm	Dmax mm	Weight kg/km	Dmin mm	Dmax mm	Weight kg/km
4	8	19,2	9	20,8	250	8	25,2	9	26,8	395	6,5	7,5	92	14	16,1	360
6	8	19,2	9	20,8	325	8	25,2	9	26,8	470	7,4	8	118	15,7	18	475
10	8	19,2	9	20,8	535	8	25,2	9	26,8	710	8,6	10	183	20,9	23,9	836
16	-	-	-	-	-	-	-	-	-	-	9,6	11	251	23,8	27,1	1145
25	-	-	-	-	-	-	-	-	-	-	11	13	362	28,9	32,9	1716
35	-	-	-	-	-	-	-	-	-	-	12,5	14,5	497	-	-	-
50	-	-	-	-	-	-	-	-	-	-	15	17	669	-	-	-
70	-	-	-	-	-	-	-	-	-	-	17,5	19,5	901	-	-	-
95	-	-	-	-	-	-	-	-	-	-	20,5	22,5	1141	-	-	-
120	-	-	-	-	-	-	-	-	-	-	22	24,4	1435	-	-	-
150	-	-	-	-	-	-	-	-	-	-	25,2	28,3	1795	-	-	-
185	-	-	-	-	-	-	-	-	-	-	27,6	31	2156	-	-	-
240	-	-	-	-	-	-	-	-	-	-	30,6	34,5	2760	-	-	-

L-cavi-en\_a\_td

## CP6W, 50 Hz: SIZING OF ETHYLENE-PROPILENE (EPR) CABLES DIRECT START

MOTOR TYPE THREE-PHASE	RATED POWER Kw   HP		RATED VOLTAGE V	Cos φ	RATED CURRENT A	VOLTAGE DROP %	Cable cross section: 4G x ...mm <sup>2</sup>								
							mm2	4	6	10	16	25	35	50	70
							A max	42	54	75	100	127	158	192	246
							Maximum length in metres								
CP6W40T405	4	5,5	380	0,90	9,89	4		187	281	484					
			415	0,85	9,13										
CP6W55T405	5,5	7,5	380	0,88	12,7			148	222	384					
			415	0,82	12,5										
CP6W75T405	7,5	10	380	0,90	17,0			106	161	279	439				
			415	0,84	16,2										
CP6W93T405	9,3	12,5	380	0,89	20,5			87	133	233	366	561			
			415	0,83	19,9										
CP6W110T405	11	15	380	0,90	24,2			71	110	194	306	470			
			415	0,84	23,4										
CP6W130T405	13	17,5	380	0,90	28,1			60	93	165	262	403	561		
			415	0,85	27,0										
CP6W150T405	15	20	380	0,88	32,1			52	82	146	233	358	498		
			415	0,82	31,3										
CP6W185T405	18,5	25	380	0,89	38,5			-	65	118	190	294	410		
			415	0,83	37,5										
CP6W220T405	22	30	380	0,87	47,3			-	51	95,1	155	241	337	472	
			415	0,80	46,7										
CP6W260T405	26	35	380	0,85	56,5			-	-	78	129	202	284	398	
			415	0,79	55,7										
CP6W300T405	30	40	380	0,87	63,8		-	-	66	110	174	245	346	479	
			415	0,81	62,0										
CP6W370T405	37	50	380	0,86	81,8		-	-	-	82	132	188	267	372	
			415	0,80	79,4										

Exposed cable laid at a temperature of 30°C, maximum conductor temperature of 90°C

cp6w-cavi-50-en\_c\_te

## CP6W, 50 Hz: SIZING OF ETHYLENE-PROPILENE (EPR) CABLES STAR / DELTA START

MOTOR TYPE THREE-PHASE	RATED POWER Kw   HP		RATED VOLTAGE V	Cos φ	RATED CURRENT A	VOLTAGE DROP %	Cable cross section: 4G x ...mm <sup>2</sup> + 3 x ...mm <sup>2</sup>											
							mm <sup>2</sup>	4	6	10	16	25	35	50	70			
							A max*	73	94	130	173	220	274	333	426			
							Maximum length in metres											
CP6W40T405	4	5,5	380 415	0,90 0,85	9,89 9,13	4		327	490									
CP6W55T405	5,5	7,5	380 415	0,88 0,82	12,7 12,5			260	389									
CP6W75T405	7,5	10	380 415	0,90 0,84	17,0 16,2			189	283	488								
CP6W93T405	9,3	12,5	380 415	0,89 0,83	20,5 19,9			157	237	408								
CP6W110T405	11	15	380 415	0,90 0,84	24,2 23,4			131	197	341	535							
CP6W130T405	13	17,5	380 415	0,90 0,85	28,1 27,0			111	169	293	460							
CP6W150T405	15	20	380 415	0,88 0,82	32,1 31,3			99	150	261	410							
CP6W185T405	18,5	25	380 415	0,89 0,83	38,5 37,5			80	122	214	337	517						
CP6W220T405	22	30	380 415	0,87 0,80	47,3 46,7			64	99,5	176	278	426						
CP6W260T405	26	35	380 415	0,85 0,79	56,5 55,7			53	83	148	236	362	502					
CP6W300T405	30	40	380 415	0,87 0,81	63,8 62,0			44	70,2	127	203	313	436					
CP6W370T405	37	50	380 415	0,86 0,80	81,8 79,4			-	52	96	157	243	340	476				

Exposed cable laid at a temperature of 30°C, maximum conductor temperature of 90°C

cp6w-cavi-SD-50-en\_c\_te

\*A max is the maximum rated current of the motor

## CP8W, 50 Hz: SIZING OF ETHYLENE-PROPILENE (EPR) CABLES DIRECT START

MOTOR TYPE THREE-PHASE	RATED POWER Kw   HP		RATED VOLTAGE V	Cos φ	RATED CURRENT A	VOLTAGE DROP %	Cable cross section: 4G x ...mm <sup>2</sup>									
							mm <sup>2</sup>	10	16	25	35	50	70	95	120	
							A max	75	100	127	158	192	246	298	346	
Maximum length in metres																
CP8W300T405	30	40	380	0,85	65,0	4		65	110	173	244	344	475			
			415	0,84	59,0											
CP8W370T405	37	50	380	0,87	81,0			47	82	132	189	268	374	476		
			415	0,83	76,0											
CP8W450T405	45	60	380	0,87	92,0			-	69	113	163	233	327	417	516	
			415	0,83	88,5											
CP8W520T405	52	70	380	0,86	110			-	-	91	133	192	271	347	430	
			415	0,82	104											
CP8W550T405	55	75	380	0,87	118			-	-	82	121	176	250	321	399	
			415	0,83	110											
CP8W600T405	60	80	380	0,87	124			-	-	77	114	166	236	305	378	
			415	0,83	118											
CP8W670T405	67	90	380	0,88	138			-	-	-	98	145	208	270	337	
			415	0,83	132											
CP8W750T405	75	100	380	0,87	156			-	-	-	84	125	182	237	296	
			415	0,82	148											
CP8W830T405	83	110	380	0,87	172		-	-	-	-	111	162	212	266		
			415	0,82	163											
CP8W930T405	93	125	380	0,87	192		-	-	-	-	95	142	187	236		
			415	0,83	180											

Exposed cable laid at a temperature of 30°C, maximum conductor temperature of 90°C

cp8w-cavi-50-en\_b\_te

\*A max is the maximum rated current of the motor

## CP8W, 50 Hz: SIZING OF ETHYLENE-PROPILENE (EPR) CABLES STAR / DELTA START

MOTOR TYPE THREE-PHASE	RATED POWER Kw   HP		RATED VOLTAGE V	Cos φ	RATED CURRENT A	VOLTAGE DROP %	Cable cross section: 4G x ...mm <sup>2</sup> + 3 x ...mm <sup>2</sup>								
							mm <sup>2</sup>	6	10	16	25	35	50	70	95
							A max*	94	130	173	220	274	333	426	516
Maximum length in metres															
CP8W300T405	30	40	380	0,85	65,0	4		70	127	203	313	435			
			415	0,84	59,0										
CP8W370T405	37	50	380	0,87	81,0			52	96	157	244	341	478		
			415	0,83	76,0										
CP8W450T405	45	60	380	0,87	92,0			44	83	136	212	298	419		
			415	0,83	88,5										
CP8W520T405	52	70	380	0,86	110			-	67	112	176	248	350	484	
			415	0,82	104										
CP8W550T405	55	75	380	0,87	118			-	60	102	161	228	323	447	
			415	0,83	110										
CP8W600T405	60	80	380	0,87	124			-	56	96	152	216	306	425	541
			415	0,83	118										
CP8W670T405	67	90	380	0,88	138			-	-	83	133	191	271	378	483
			415	0,83	132										
CP8W750T405	75	100	380	0,87	156			-	-	71	116	167	239	334	427
			415	0,82	148										
CP8W830T405	83	110	380	0,87	172			-	-	62,2	103	149	214	301	385
			415	0,82	163										
CP8W930T405	93	125	380	0,87	192		-	-	53	89	131	189	267	343	
			415	0,83	180										

Exposed cable laid at a temperature of 30°C, maximum conductor temperature of 90°C

cp8w-cavi-SD-50-en\_b\_te

\*A max is the maximum rated current of the motor

## CP10W, 50 Hz: SIZING OF ETHYLENE-PROPILENE (EPR) CABLES DIRECT START

MOTOR TYPE THREE-PHASE	RATED POWER Kw   HP		RATED VOLTAGE V	Cos φ	RATED CURRENT A	VOLTAGE DROP %	Cable cross section: 4G x ...mm <sup>2</sup>								
							mm <sup>2</sup>	35	50	70	95	120	150	185	240
							A max	158	192	246	298	346	399	456	538
Maximum length in metres															
CP10W930T405	93	125	380	0,87	191	4		-	96	143	188	237	286	336	411
			415	0,84	180										
CP10W1100T405	110	150	380	0,86	235			-	-	110	147	187	228	268	329
			415	0,82	220										
CP10W1300T405	130	175	380	0,86	270			-	-	-	124	159	194	230	283
			415	0,83	255										
CP10W1500T405	150	200	380	0,86	308			-	-	-	-	135	166	198	245
			415	0,84	285										

Exposed cable laid at a temperature of 30°C, maximum conductor temperature of 90°C

cp10w-cavi-50-en\_b\_te

## CP10W, 50 Hz: SIZING OF ETHYLENE-PROPILENE (EPR) CABLES STAR / DELTA START

MOTOR TYPE THREE-PHASE	RATED POWER Kw   HP		RATED VOLTAGE V	Cos φ	RATED CURRENT A	VOLTAGE DROP %	Cable cross section: 4G x ...mm <sup>2</sup> + 3 x ...mm <sup>2</sup>								
							mm <sup>2</sup>	25	35	50	70	95	120	150	185
							A max*	220	274	333	426	516	599	691	790
Maximum length in metres															
CP10W930T405	93	125	380	0,87	191	4		90	132	191	269	345	428	511	
			415	0,84	180										
CP10W1100T405	110	150	380	0,86	235			-	102	150	215	278	345	412	480
			415	0,82	220										
CP10W1300T405	130	175	380	0,86	270			-	85	127	183	238	297	356	415
			415	0,83	255										
CP10W1500T405	150	200	380	0,86	308			-	-	107	157	205	257	310	362
			415	0,84	285										

Exposed cable laid at a temperature of 30°C, maximum conductor temperature of 90°C

cp10w-cavi-SD-50-en\_b\_te

\*A max is the maximum rated current of the motor

## CP12W, 50 Hz: SIZING OF ETHYLENE-PROPILENE (EPR) CABLES DIRECT START

MOTOR TYPE THREE-PHASE	RATED POWER Kw   HP		RATED VOLTAGE V	Cos φ	RATED CURRENT A	VOLTAGE DROP %	Cable cross section: 4G x ...mm <sup>2</sup>									
							mm <sup>2</sup>	50	70	95	120	150	185	240	300	
							A max	192	246	298	346	399	456	538	621	
Maximum length in metres																
CP12W1850T405	185	250	380	0,87	380	4		-	-	-	-	127	154	194	229	
			415	0,86	360											
CP12W2200T405	220	300	380	0,86	470			-	-	-	-	-	-	-	150	179
			415	0,83	435											
CP12W2600T405	260	350	380	0,87	525			-	-	-	-	-	-	-	131	158
			415	0,83	498											
CP12W3000T405	300	400	380	0,87	620			-	-	-	-	-	-	-	-	128
			415	0,84	570											

Exposed cable laid at a temperature of 30°C, maximum conductor temperature of 90°C

cp12w-cavi-50-en\_b\_te

## CP12W, 50 Hz: SIZING OF ETHYLENE-PROPILENE (EPR) CABLES STAR / DELTA START

MOTOR TYPE THREE-PHASE	RATED POWER Kw   HP		RATED VOLTAGE V	Cos φ	RATED CURRENT A	VOLTAGE DROP %	Cable cross section: 4G x ...mm <sup>2</sup> + 3 x ...mm <sup>2</sup>								
							mm <sup>2</sup>	50	70	95	120	150	185	240	300
							A max*	333	426	516	599	691	790	932	1076
Maximum length in metres															
CP12W1850T405	185	250	380	0,87	380	4		-	120	160	203	246	289	355	413
			415	0,86	360										
CP12W2200T405	220	300	380	0,86	470			-	-	123	158	193	229	282	329
			415	0,83	435										
CP12W2600T405	260	350	380	0,87	525			-	-	-	137	169	202	251	294
			415	0,83	498										
CP12W3000T405	300	400	380	0,87	620			-	-	-	-	138	166	208	245
			415	0,84	570										

Exposed cable laid at a temperature of 30°C, maximum conductor temperature of 90°C

cp12w-cavi-SD-50-en\_b\_te

\*A max is the maximum rated current of the motor



## SPLICE BETWEEN DROP CABLE AND MOTOR CABLE

MOTOR TYPE	POWER kW	TYPE OF SPLICE	FOUR-CORE DROP CABLE - SECTION (mm <sup>2</sup> )																
			1,5	2,5	4	6	10	16	25	35	50	70	95	120	150	185	240	300	
CP40 CP4C	0,37 - 7,5	Resin-filled method	GR1	GR1	GR1	GR2	GR2	GR6	GR6	GR6	GR4	GR5	GR5	-	-	-	-	-	
		Heat-shrink method	GT1	GT1	GT2	GT2	GT3	GT4	GT5	GT6	-	-	-	-	-	-	-	-	-
		Tape method	Self-vulcanizing tape + self-vulcanizing sealing putty and PVC tape (1)																
CP6C CP6W	4 - 37	Resin-filled method	-	-	GR1	GR2	GR2	GR6	GR6	GR6	GR4	GR5	GR5	-	-	-	-	-	
		Heat-shrink method	-	-	GT2	GT2	GT3	GT4	GT5	GT6	-	-	-	-	-	-	-	-	-
		Tape method	Self-vulcanizing tape + self-vulcanizing sealing putty and PVC tape (1)																

MOTOR TYPE	POWER kW	TYPE OF SPLICE	THREE-CORE DROP CABLE - SECTION (mm <sup>2</sup> )																
			1,5	2,5	4	6	10	16	25	35	50	70	95	120	150	185	240	300	
CP6C CP6W	4 - 37	Resin-filled method	-	-	GR1	GR1	GR2	GR2	GR6	GR6	GR6	GR4	GR5	-	-	-	-	-	
		Heat-shrink method	-	-	GT2	GT2	GT3	GT4	GT5	GT6	-	-	-	-	-	-	-	-	-
		Tape method	Self-vulcanizing tape + PVC tape																

MOTOR TYPE	POWER kW	TYPE OF SPLICE	SINGLE-CORE DROP CABLE - SECTION (mm <sup>2</sup> )																
			1,5	2,5	4	6	10	16	25	35	50	70	95	120	150	185	240	300	
CP8W CP10W CP12W	30 - 300	Resin-filled method	-	-	-	GR1	GR1	GR1	GR1	GR1	GR1	GR2	GR2	GR2	GR6	GR6	GR6	GR4	
		Heat-shrink method	-	-	-	-	-	-	-	-	-	-	-	-	-	-	-	-	-
		Tape method	Self-vulcanizing tape + PVC tape																

(1) Use self-vulcanizing sealing putty to fill in the gaps between the three-conductor cable and the ground cable in the area covered by the final layer of tape, to restore continuity to the protective sheath.

RESIN-FILLED SPLICES				HEAT-SHRINK SPLICES			
TYPE	L [mm]	TYPE	L [mm]	TYPE	L [mm]	TYPE	L [mm]
GR1	148 x 32	GR5	369 x 76	GT1	450	GT4	450
GR2	178 x 36	GR6	270 x 55	GT2	450	GT5	500
GR4	319 x 63			GT3	450	GT6	500

CP-giunzioni-en\_d\_te

## CALCULATING THE SPEED OF THE FLUID THAT FLOWS AROUND A SUBMERGED MOTOR AND SIZING OF THE COOLING SLEEVE

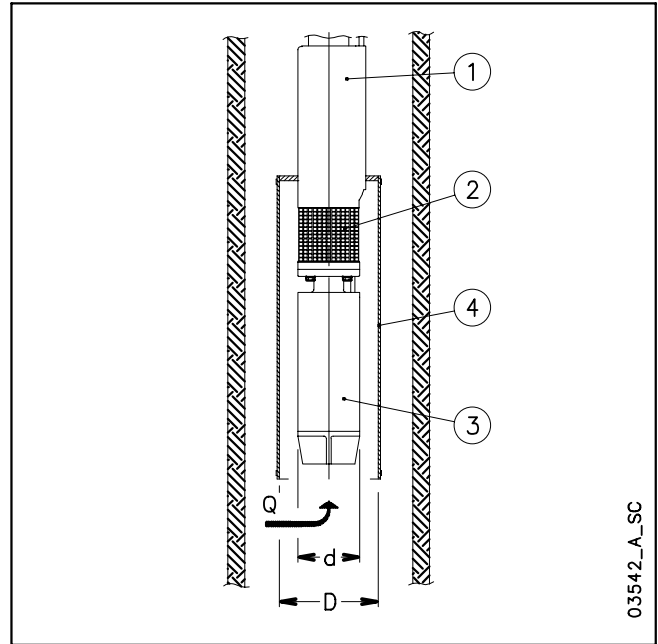
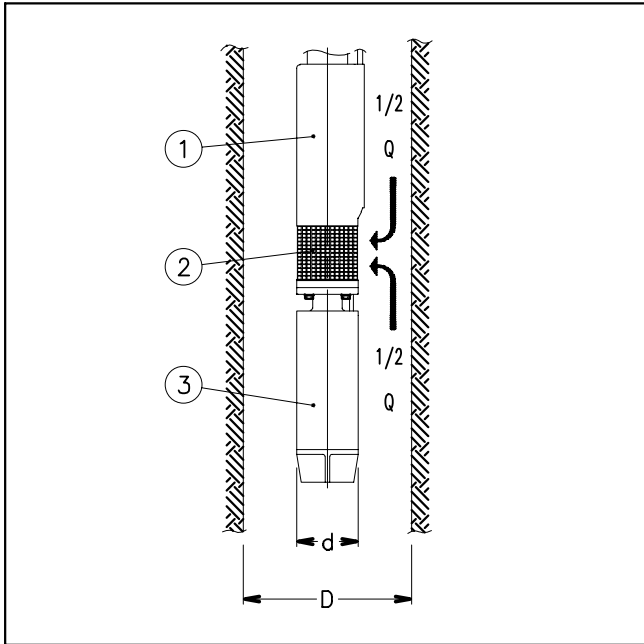

03542\_A\_SC

The following formula is used to verify whether the speed of the fluid that flows around the motor of a submersible pump is high enough to guarantee the proper cooling of the motor:

$$v = \frac{\frac{Q}{2}}{\pi \cdot \left( \frac{D^2}{4} - \frac{d^2}{4} \right)}$$

Where: Q in [m<sup>3</sup>/s] is the operating flow rate of the electric pump; only half of this flow is taken into account, because the fluid which is sucked into the area of the filter (2), comes from the motor side (3) as well as from the pump side (1);  
D in [m] corresponds to the diameter of the well;  
d in [m] corresponds to the diameter of the motor (3);  
v in [m/s] is the calculated speed of the fluid that flows around the motor.

Now, compare the speed thus calculated (v) with the minimum speed required for correct cooling of the motor (v<sub>m</sub>): if v ≥ v<sub>m</sub> it means that the motor is properly cooled, if v < v<sub>m</sub> will be necessary to mount a cooling sleeve (4).

### Example:

An electric pump OZ630/12 (motor diameter d = 0.144 m) operates in an 8" well (well diameter D = 0.203 m) with flow rate Q = 20 m<sup>3</sup>/h = 0.0055 m<sup>3</sup>/s.

Speed of fluid v = (0.0055/2) / {π·[(0.203)<sup>2</sup>/4 – (0.144)<sup>2</sup>/4]} = 0.17 m/s.

The minimum speed required for proper motor cooling is v<sub>m</sub> = 0.20 m/s.

Because v < v<sub>m</sub>, it will be necessary to mount a cooling sleeve.

The following formula is used to determine the maximum diameter of a cooling sleeve to be mounted on a submersible motor:

$$D = \sqrt{4 \cdot \left( \frac{Q}{v \cdot \pi} + \frac{d^2}{4} \right)}$$

Where: Q in [m<sup>3</sup>/s] is the operating flow rate of the electric pump; the entire flow is taken into account because the fluid comes from the motor side (3) only;  
D in [m] corresponds to the diameter of the cooling sleeve (4);  
d in [m] corresponds to the diameter of the motors(3);  
v<sub>m</sub> in [m/s] is the minimum speed of the fluid that flows around the motor.

If the electric pump operates at different flow rate, the minimum flow rate must be taken into account for calculating the diameter of the cooling sleeve.

### Example:

A motor coupled to the electric pump OZ615/24 (motor diameter d = 0.144 m), which operates with flow rate Q = 15 m<sup>3</sup>/h = 0.0042 m<sup>3</sup>/s, requires a minimum speed of the fluid of v<sub>m</sub> = 0.20 m/s.

Cooling sleeve diameter D = {4·[(0.0042/(0.2·π)+(0.144)<sup>2</sup>/4]}<sup>0.5</sup> = 0.217 m.

## ASYNCHRONOUS MOTOR STARTING SYSTEMS

### Direct

Suitable for low-power motors.

The starting current ( $I_s$ ) is much higher than the rated current ( $I_n$ ).

Starting current  $I_s = I_n \times 4 \div 8$

Starting torque  $T_s = T_n \times 2 \div 3$

### Indirect

#### • Star/Delta

The starting current ( $I_s$ ) is three times less than the direct starting current.

Starting current  $I_s = I_n \times 1.3 \div 2.7$

Starting torque  $T_s = T_n \times 0.7 \div 1$

In the star to delta changeover phase (approx. 70 ms) the motor is not supplied and tends to reduce its rotation speed.

In the case of submersible electric pumps with power above 10 HP, the modest mass of the rotor causes a slowdown at changeover, so that the initial Star supply phase is rendered partially useless.

In such cases we recommend using impedance panels or an autotransformer.

#### • Impedances

The motor is started with a voltage which is lower than the rated one, and which is obtained by means of impedances.

The Goulds panels use impedances which cut down to 70% the starting voltage.

The switch to the rated voltage takes place without any interruptions of the power supply.

Rated voltage  $U_n = 400 \text{ V}$

Starting voltage  $U_s = U_n \times 0,7 = 280 \text{ V}$

Starting current

$$I_s = I_n \times 4 \div 8 \times \left( \frac{U_s}{U_n} \right) = I_n \times 3 \div 6$$

Starting torque

$$T_s = T_n \times 2 \div 3 \times \left( \frac{U_s}{U_n} \right)^2 = T_n \times 1 \div 1,5$$

### Autotransformer

The pump is started with a voltage which is lower than the rated one.

The Goulds panels use an autotransformer with a voltage that is 70% the value of the line voltage.

The switch to the rated voltage occurs without any interruptions of the power supply.

Rated voltage  $U_n = 400 \text{ V}$

Starting current

$$I_s = I_n \times 4 \div 8 \times \left( \frac{U_s}{U_n} \right) = I_n \times 3 \div 6$$

Starting torque

$$T_s = T_n \times 2 \div 3 \times \left( \frac{U_s}{U_n} \right)^2 = T_n \times 1 \div 1,5$$

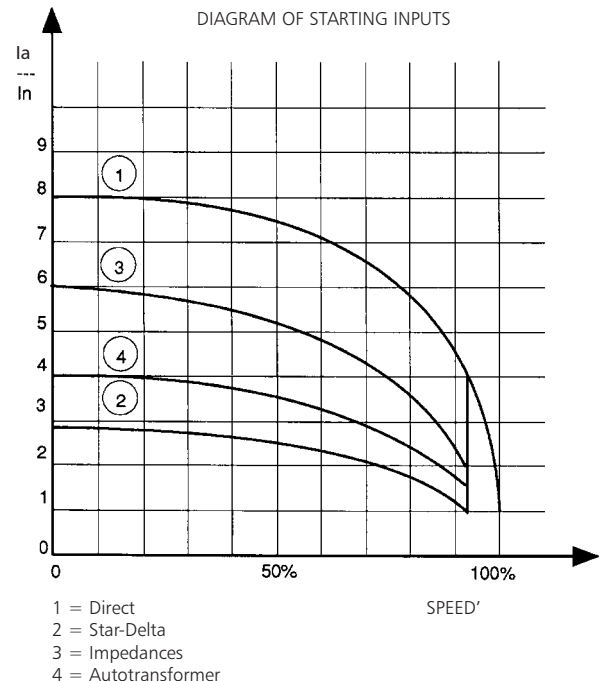

## WATER REQUIREMENTS IN CIVIL USERS

Determination of the water requirement depends on the type of users and contemporaneity factor. The calculation may be subject to regulations, standards or customs that may vary from country to country. The calculation method shown below is an example based on practical experience, designed to provide a reference value and not a substitute for detailed analytical calculation.

### Water requirements in condominiums

The **consumption table** shows the maximum values for each delivery point, depending on the plumbing amenities.

### MAXIMUM CONSUMPTION FOR EACH DELIVERY POINT

TYPE	CONSUMPTION (l/min)
Sink	9
Dishwasher	10
Washing machine	12
Shower	12
Bathtub	15
Washbasin	6
Bidet	6
Flush tank WC	6
Controlled flushing system WC	90

G-at-cm\_a\_th

The **sum of the water consumption values** of each delivery point determines the maximum theoretical requirement, which must be reduced according to the **contemporaneity coefficient**, because in actual fact the delivery points are never used all together.

$f = \frac{1}{\sqrt{(0,857 \times Nr \times Na)}}$	Coefficient for apartments with one bathroom and flush tank WC
$f = \frac{1}{\sqrt{(0,857 \times Nr \times Na)}}$	Coefficient for apartments with one bathroom and controlled flushing system WC
$f = \frac{1,03}{\sqrt{(0,545 \times Nr \times Na)}}$	Coefficient for apartments with two bathrooms and flush tank WC
$f = \frac{0,8}{\sqrt{(0,727 \times Nr \times Na)}}$	Coefficient for apartments with two bathrooms and controlled flushing system WC
f= coefficient; Nr= number of delivery points; Na= number of apartments	

The **table of water requirements in civil users** shows the maximum contemporaneity flow-rate values based on the **number of apartments** and the type of WC for apartments with one bathroom and two bathrooms. As regards apartments with one bathroom, 7 drawing points have been taken into consideration, while 11 points have been considered for apartments with two bathrooms. If the number of drawing points or apartments is different, use the formulas to **calculate** the requirement.

## TABLE OF WATER REQUIREMENTS IN CIVIL USERS

NUMBER OF APARTMENTS	WITH FLUSH TANK WC		WITH CONTROLLED FLUSHING SYSTEM WC	
	1	2	1	2
	FLOW RATE (l/min)			
1	32	40	60	79
2	45	56	85	111
3	55	68	105	136
4	63	79	121	157
5	71	88	135	176
6	78	97	148	193
7	84	105	160	208
8	90	112	171	223
9	95	119	181	236
10	100	125	191	249
11	105	131	200	261
12	110	137	209	273
13	114	143	218	284
14	119	148	226	295
15	123	153	234	305
16	127	158	242	315
17	131	163	249	325
18	134	168	256	334
19	138	172	263	343
20	142	177	270	352
21	145	181	277	361
22	149	185	283	369
23	152	190	290	378
24	155	194	296	386
25	158	198	302	394
26	162	202	308	401
27	165	205	314	409
28	168	209	320	417
29	171	213	325	424
30	174	217	331	431
35	187	234	357	466
40	200	250	382	498
45	213	265	405	528
50	224	280	427	557
55	235	293	448	584
60	245	306	468	610
65	255	319	487	635
70	265	331	506	659
75	274	342	523	682
80	283	354	540	704
85	292	364	557	726
90	301	375	573	747
95	309	385	589	767
100	317	395	604	787
120	347	433	662	863
140	375	468	715	932
160	401	500	764	996
180	425	530	811	1056
200	448	559	854	1114

For seaside resorts, a flow rate increased by at least 20% must be considered.

G-at-fi\_a\_th

## WATER REQUIREMENTS FOR COMMUNITY BUILDINGS

The requirements of buildings intended for specific uses, such as **offices, residential units, hotels, department stores, nursing homes** and so on, are different from those of condominiums, and both their global daily water consumption and the maximum contemporaneity flow rate are usually greater. The **diagram of water requirements for community buildings** shows the maximum contemporaneity flow rate of some types of communities, for guidance.

These requirements must be determined case by case with the utmost accuracy, using analytical calculation methods, according to particular needs and local provisions.

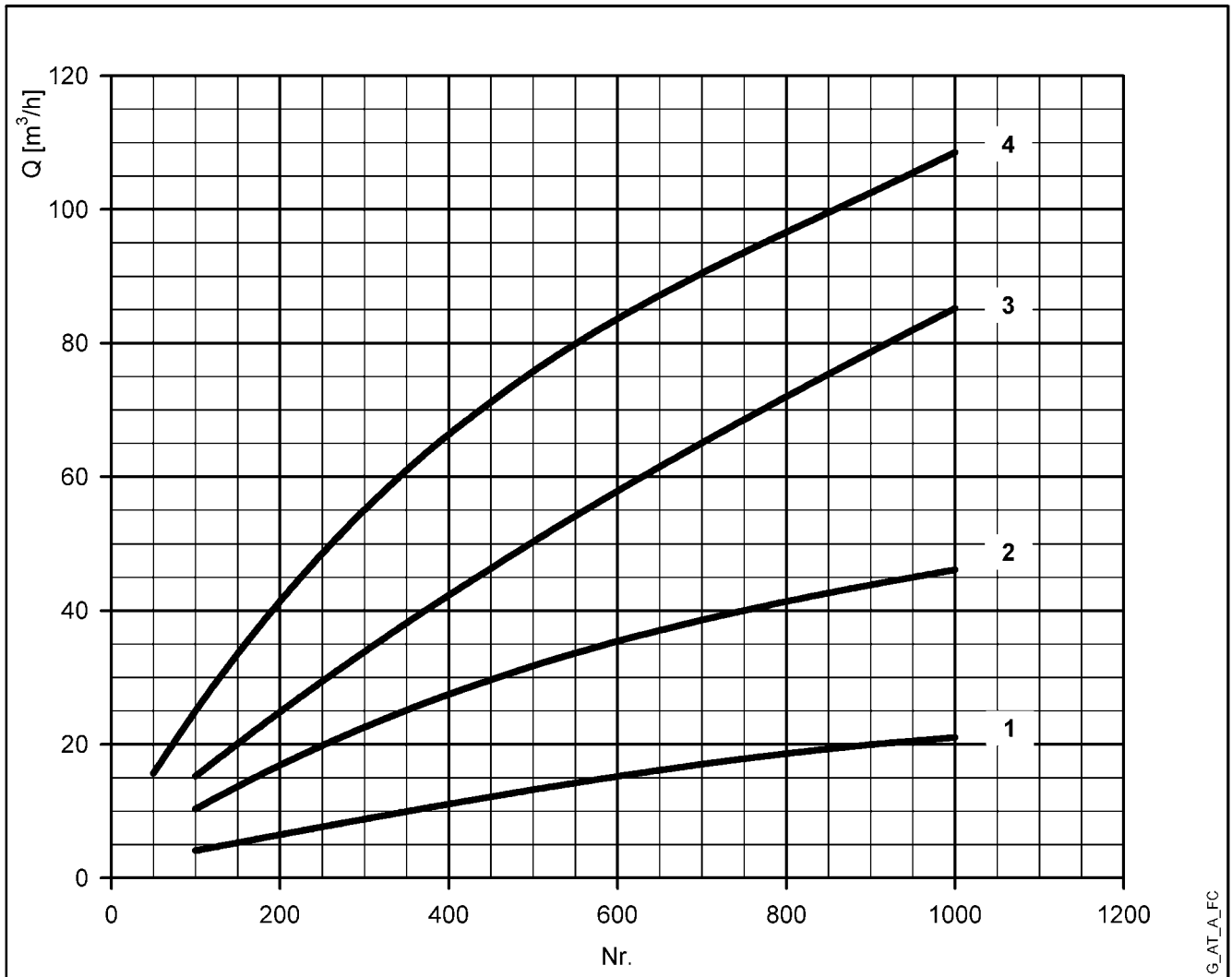

For seaside resorts, the flow rate must be increased by at least 20%.

- 1 = Offices (N. of people)
- 2 = Department stores (N. of people)
- 3 = Nursing homes (N. of beds)
- 4 = Hotels, residences (N. of beds)

## NPSH

The minimum operating values that can be reached at the pump suction end are limited by the onset of cavitation.

Cavitation is the formation of vapour-filled cavities within liquids where the pressure is locally reduced to a critical value, or where the local pressure is equal to, or just below the vapour pressure of the liquid.

The vapour-filled cavities flow with the current and when they reach a higher pressure area the vapour contained in the cavities condenses. The cavities collide, generating pressure waves that are transmitted to the walls. These, being subjected to stress cycles, gradually become deformed and yield due to fatigue. This phenomenon, characterized by a metallic noise produced by the hammering on the pipe walls, is called incipient cavitation.

The damage caused by cavitation may be magnified by electrochemical corrosion and a local rise in temperature due to the plastic deformation of the walls. The materials that offer the highest resistance to heat and corrosion are alloy steels, especially austenitic steel. The conditions that trigger cavitation may be assessed by calculating the total net suction head, referred to in technical literature with the acronym NPSH (Net Positive Suction Head).

The NPSH represents the total energy (expressed in m.) of the liquid measured at suction under conditions of incipient cavitation, excluding the vapour pressure (expressed in m.) that the liquid has at the pump inlet.

To find the static height  $h_z$  at which to install the machine under safe conditions, the following formula must be verified:

$$h_p + h_z \geq (\text{NPSH}_r + 0.5) + h_f + h_{pv} \quad \textcircled{1}$$

where:

- h<sub>p</sub>** is the absolute pressure applied to the free liquid surface in the suction tank, expressed in m. of liquid;  $h_p$  is the quotient between the barometric pressure and the specific weight of the liquid.
- h<sub>z</sub>** is the suction lift between the pump axis and the free liquid surface in the suction tank, expressed in m.;  $h_z$  is negative when the liquid level is lower than the pump axis.
- h<sub>f</sub>** is the flow resistance in the suction line and its accessories, such as: fittings, foot valve, gate valve, elbows, etc.
- h<sub>pv</sub>** is the vapour pressure of the liquid at the operating temperature, expressed in m. of liquid.  $h_{pv}$  is the quotient between the Pv vapour pressure and the liquid's specific weight.
- 0,5** is the safety factor.

The maximum possible suction head for installation depends on the value of the atmospheric pressure (i.e. the elevation above sea level at which the pump is installed) and the temperature of the liquid.

To help the user, with reference to water temperature (4° C) and to the elevation above sea level, the following tables show the drop in hydraulic pressure head in relation to the elevation above sea level, and the suction loss in relation to temperature.

Water temperature (°C)	20	40	60	80	90	110	120
Suction loss (m)	0,2	0,7	2,0	5,0	7,4	15,4	21,5

Elevation above sea level (m)	500	1000	1500	2000	2500	3000
Suction loss (m)	0,55	1,1	1,65	2,2	2,75	3,3

Friction loss is shown in the tables at pages 113-114 of this catalogue. To reduce it to a minimum, especially in cases of high suction head (over 4-5 m.) or within the operating limits with high flow rates, we recommend using a suction line having a larger diameter than that of the pump's suction port. It is always a good idea to position the pump as close as possible to the liquid to be pumped.

Make the following calculation:

Liquid: water at ~15°C  $\gamma = 1 \text{ kg/dm}^3$

Flow rate required: 30 m<sup>3</sup>/h

Head for required delivery: 43 m.

Suction lift: 3,5 m.

The selection is an GFHE 40-200/75 pump whose NPSH required value is, at 30 m<sup>3</sup>/h, di 2,5 m.

For water at 15 °C

$$h_p = P_a / \gamma = 10,33\text{m}, h_{pv} = P_v / \gamma = 0,174\text{m} (0,01701 \text{ bar})$$

The H<sub>f</sub> flow resistance in the suction line with foot valves is ~ 1,2 m.

By substituting the parameters in formula  $\textcircled{1}$  with the numeric values above, we have:

$$10,33 + (-3,5) \geq (2,5 + 0,5) + 1,2 + 0,17$$

from which we have: 6,8 > 4,4

The relation is therefore verified.

## TECHNICAL APPENDIX VAPOUR PRESSURE PS VAPOUR PRESSURE AND $\rho$ DENSITY OF WATER TABLE

t °C	T K	ps bar	$\rho$ kg/dm <sup>3</sup>	t °C	T K	ps bar	$\rho$ kg/dm <sup>3</sup>	t °C	T K	ps bar	$\rho$ kg/dm <sup>3</sup>
0	273,15	0,00611	0,9998	55	328,15	0,15741	0,9857	120	393,15	1,9854	0,9429
1	274,15	0,00657	0,9999	56	329,15	0,16511	0,9852	122	395,15	2,1145	0,9412
2	275,15	0,00706	0,9999	57	330,15	0,17313	0,9846	124	397,15	2,2504	0,9396
3	276,15	0,00758	0,9999	58	331,15	0,18147	0,9842	126	399,15	2,3933	0,9379
4	277,15	0,00813	1,0000	59	332,15	0,19016	0,9837	128	401,15	2,5435	0,9362
5	278,15	0,00872	1,0000	60	333,15	0,1992	0,9832	130	403,15	2,7013	0,9346
6	279,15	0,00935	1,0000	61	334,15	0,2086	0,9826	132	405,15	2,867	0,9328
7	280,15	0,01001	0,9999	62	335,15	0,2184	0,9821	134	407,15	3,041	0,9311
8	281,15	0,01072	0,9999	63	336,15	0,2286	0,9816	136	409,15	3,223	0,9294
9	282,15	0,01147	0,9998	64	337,15	0,2391	0,9811	138	411,15	3,414	0,9276
10	283,15	0,01227	0,9997	65	338,15	0,2501	0,9805	140	413,15	3,614	0,9258
11	284,15	0,01312	0,9997	66	339,15	0,2615	0,9799	145	418,15	4,155	0,9214
12	285,15	0,01401	0,9996	67	340,15	0,2733	0,9793	155	428,15	5,433	0,9121
13	286,15	0,01497	0,9994	68	341,15	0,2856	0,9788	160	433,15	6,181	0,9073
14	287,15	0,01597	0,9993	69	342,15	0,2984	0,9782	165	438,15	7,008	0,9024
15	288,15	0,01704	0,9992	70	343,15	0,3116	0,9777	170	443,15	7,920	0,8973
16	289,15	0,01817	0,9990	71	344,15	0,3253	0,9770	175	448,15	8,924	0,8921
17	290,15	0,01936	0,9988	72	345,15	0,3396	0,9765	180	453,15	10,027	0,8869
18	291,15	0,02062	0,9987	73	346,15	0,3543	0,9760	185	458,15	11,233	0,8815
19	292,15	0,02196	0,9985	74	347,15	0,3696	0,9753	190	463,15	12,551	0,8760
20	293,15	0,02337	0,9983	75	348,15	0,3855	0,9748	195	468,15	13,987	0,8704
21	294,15	0,24850	0,9981	76	349,15	0,4019	0,9741	200	473,15	15,550	0,8647
22	295,15	0,02642	0,9978	77	350,15	0,4189	0,9735	205	478,15	17,243	0,8588
23	296,15	0,02808	0,9976	78	351,15	0,4365	0,9729	210	483,15	19,077	0,8528
24	297,15	0,02982	0,9974	79	352,15	0,4547	0,9723	215	488,15	21,060	0,8467
25	298,15	0,03166	0,9971	80	353,15	0,4736	0,9716	220	493,15	23,198	0,8403
26	299,15	0,03360	0,9968	81	354,15	0,4931	0,9710	225	498,15	25,501	0,8339
27	300,15	0,03564	0,9966	82	355,15	0,5133	0,9704	230	503,15	27,976	0,8273
28	301,15	0,03778	0,9963	83	356,15	0,5342	0,9697	235	508,15	30,632	0,8205
29	302,15	0,04004	0,9960	84	357,15	0,5557	0,9691	240	513,15	33,478	0,8136
30	303,15	0,04241	0,9957	85	358,15	0,5780	0,9684	245	518,15	36,523	0,8065
31	304,15	0,04491	0,9954	86	359,15	0,6011	0,9678	250	523,15	39,776	0,7992
32	305,15	0,04753	0,9951	87	360,15	0,6249	0,9671	255	528,15	43,246	0,7916
33	306,15	0,05029	0,9947	88	361,15	0,6495	0,9665	260	533,15	46,943	0,7839
34	307,15	0,05318	0,9944	89	362,15	0,6749	0,9658	265	538,15	50,877	0,7759
35	308,15	0,05622	0,9940	90	363,15	0,7011	0,9652	270	543,15	55,058	0,7678
36	309,15	0,05940	0,9937	91	364,15	0,7281	0,9644	275	548,15	59,496	0,7593
37	310,15	0,06274	0,9933	92	365,15	0,7561	0,9638	280	553,15	64,202	0,7505
38	311,15	0,06624	0,9930	93	366,15	0,7849	0,9630	285	558,15	69,186	0,7415
39	312,15	0,06991	0,9927	94	367,15	0,8146	0,9624	290	563,15	74,461	0,7321
40	313,15	0,07375	0,9923	95	368,15	0,8453	0,9616	295	568,15	80,037	0,7223
41	314,15	0,07777	0,9919	96	369,15	0,8769	0,9610	300	573,15	85,927	0,7122
42	315,15	0,08198	0,9915	97	370,15	0,9094	0,9602	305	578,15	92,144	0,7017
43	316,15	0,09639	0,9911	98	371,15	0,9430	0,9596	310	583,15	98,70	0,6906
44	317,15	0,09100	0,9907	99	372,15	0,9776	0,9586	315	588,15	105,61	0,6791
45	318,15	0,09582	0,9902	100	373,15	1,0133	0,9581	320	593,15	112,89	0,6669
46	319,15	0,10086	0,9898	102	375,15	1,0878	0,9567	325	598,15	120,56	0,6541
47	320,15	0,10612	0,9894	104	377,15	1,1668	0,9552	330	603,15	128,63	0,6404
48	321,15	0,11162	0,9889	106	379,15	1,2504	0,9537	340	613,15	146,05	0,6102
49	322,15	0,11736	0,9884	108	381,15	1,3390	0,9522	350	623,15	165,35	0,5743
50	323,15	0,12335	0,9880	110	383,15	1,4327	0,9507	360	633,15	186,75	0,5275
51	324,15	0,12961	0,9876	112	385,15	1,5316	0,9491	370	643,15	210,54	0,4518
52	325,15	0,13613	0,9871	114	387,15	1,6362	0,9476	374,15	647,30	221,20	0,3154
53	326,15	0,14293	0,9862	116	389,15	1,7465	0,9460				
54	327,15	0,15002	0,9862	118	391,15	1,8628	0,9445				

G-at\_nps\_h\_a\_sc



## TABLE OF FLOW RESISTANCE IN 100 m OF STRAIGHT CAST IRON PIPELINE (HAZEN-WILLIAMS FORMULA C=100)

FLOW RATE		NOMINAL DIAMETER in mm and INCHES																	
m <sup>3</sup> /h	l/min	15	20	25	32	40	50	65	80	100	125	150	175	200	250	300	350	400	
		1/2"	3/4"	1"	1 1/4"	1 1/2"	2	2 1/2"	3"	4"	5"	6"	7"	8"	10"	12"	14"	16"	
0,6	10	v 0,94	v 0,53	v 0,34	v 0,21	v 0,13													
		hr 16	hr 3,94	hr 1,33	hr 0,40	hr 0,13													
0,9	15	v 1,42	v 0,80	v 0,51	v 0,31	v 0,20													
		hr 33,9	hr 8,35	hr 2,82	hr 0,85	hr 0,29													
1,2	20	v 1,89	v 1,06	v 0,68	v 0,41	v 0,27	v 0,17												
		hr 57,7	hr 14,21	hr 4,79	hr 1,44	hr 0,49	hr 0,16												
1,5	25	v 2,36	v 1,33	v 0,85	v 0,52	v 0,33	v 0,21												
		hr 87,2	hr 21,5	hr 7,24	hr 2,18	hr 0,73	hr 0,25												
1,8	30	v 2,83	v 1,59	v 1,02	v 0,62	v 0,40	v 0,25												
		hr 122	hr 30,1	hr 10,1	hr 3,05	hr 1,03	hr 0,35												
2,1	35	v 3,30	v 1,86	v 1,19	v 0,73	v 0,46	v 0,30												
		hr 162	hr 40,0	hr 13,5	hr 4,06	hr 1,37	hr 0,46												
2,4	40	v 2,12	v 1,36	v 0,83	v 0,53	v 0,34	v 0,20												
		hr 51,2	hr 17,3	hr 5,19	hr 1,75	hr 0,59	hr 0,16												
3	50	v 2,65	v 1,70	v 1,04	v 0,66	v 0,42	v 0,25												
		hr 77,4	hr 26,1	hr 7,85	hr 2,65	hr 0,89	hr 0,25												
3,6	60	v 3,18	v 2,04	v 1,24	v 0,80	v 0,51	v 0,30												
		hr 108	hr 36,6	hr 11,0	hr 3,71	hr 1,25	hr 0,35												
4,2	70	v 3,72	v 2,38	v 1,45	v 0,93	v 0,59	v 0,35												
		hr 144	hr 48,7	hr 14,6	hr 4,93	hr 1,66	hr 0,46												
4,8	80	v 4,25	v 2,72	v 1,66	v 1,06	v 0,68	v 0,40												
		hr 185	hr 62,3	hr 18,7	hr 6,32	hr 2,13	hr 0,59												
5,4	90	v 3,06	v 1,87	v 1,19	v 0,76	v 0,45	v 0,30												
		hr 77,5	hr 23,3	hr 7,85	hr 2,65	hr 0,74	hr 0,27												
6	100	v 3,40	v 2,07	v 1,33	v 0,85	v 0,50	v 0,33												
		hr 94,1	hr 28,3	hr 9,54	hr 3,22	hr 0,90	hr 0,33												
7,5	125	v 4,25	v 2,59	v 1,66	v 1,06	v 0,63	v 0,41												
		hr 142	hr 42,8	hr 14,4	hr 4,86	hr 1,36	hr 0,49												
9	150	v 3,11	v 1,99	v 1,27	v 0,75	v 0,50	v 0,32												
		hr 59,9	hr 20,2	hr 6,82	hr 1,90	hr 0,69	hr 0,23												
10,5	175	v 3,63	v 2,32	v 1,49	v 0,88	v 0,58	v 0,37												
		hr 79,7	hr 26,9	hr 9,07	hr 2,53	hr 0,92	hr 0,31												
12	200	v 4,15	v 2,65	v 1,70	v 1,01	v 0,66	v 0,42												
		hr 102	hr 34,4	hr 11,6	hr 3,23	hr 1,18	hr 0,40												
15	250	v 5,18	v 3,32	v 2,12	v 1,26	v 0,83	v 0,53	v 0,34											
		hr 154	hr 52,0	hr 17,5	hr 4,89	hr 1,78	hr 0,60	hr 0,20											
18	300	v 3,98	v 2,55	v 1,51	v 1,00	v 0,64	v 0,41												
		hr 72,8	hr 24,6	hr 6,85	hr 2,49	hr 0,84	hr 0,28												
24	400	v 5,31	v 3,40	v 2,01	v 1,33	v 0,85	v 0,54	v 0,38											
		hr 124	hr 41,8	hr 11,66	hr 4,24	hr 1,43	hr 0,48	hr 0,20											
30	500	v 6,63	v 4,25	v 2,51	v 1,66	v 1,06	v 0,68	v 0,47											
		hr 187	hr 63,2	hr 17,6	hr 6,41	hr 2,16	hr 0,73	hr 0,30											
36	600	v 5,10	v 3,02	v 1,99	v 1,27	v 0,82	v 0,57	v 0,42											
		hr 88,6	hr 24,7	hr 8,98	hr 3,03	hr 1,02	hr 0,42	hr 0,20											
42	700	v 5,94	v 3,52	v 2,32	v 1,49	v 0,95	v 0,66	v 0,49											
		hr 118	hr 32,8	hr 11,9	hr 4,03	hr 1,36	hr 0,56	hr 0,26											
48	800	v 6,79	v 4,02	v 2,65	v 1,70	v 1,09	v 0,75	v 0,55											
		hr 151	hr 42,0	hr 15,3	hr 5,16	hr 1,74	hr 0,72	hr 0,34											
54	900	v 7,64	v 4,52	v 2,99	v 1,91	v 1,22	v 0,85	v 0,62											
		hr 188	hr 52,3	hr 19,0	hr 6,41	hr 2,16	hr 0,89	hr 0,42											
60	1000	v 5,03	v 3,32	v 2,12	v 1,36	v 0,94	v 0,69	v 0,53											
		hr 63,5	hr 23,1	hr 7,79	hr 2,63	hr 1,08	hr 0,51	hr 0,27											
75	1250	v 6,28	v 4,15	v 2,65	v 1,70	v 1,18	v 0,87	v 0,66											
		hr 96,0	hr 34,9	hr 11,8	hr 3,97	hr 1,63	hr 0,77	hr 0,40											
90	1500	v 7,54	v 4,98	v 3,18	v 2,04	v 1,42	v 1,04	v 0,80											
		hr 134	hr 48,9	hr 16,5	hr 5,57	hr 2,29	hr 1,08	hr 0,56											
105	1750	v 8,79	v 5,81	v 3,72	v 2,38	v 1,65	v 1,21	v 0,93											
		hr 179	hr 65,1	hr 21,9	hr 7,40	hr 3,05	hr 1,44	hr 0,75											
120	2000	v 6,63	v 4,25	v 2,72	v 1,89	v 1,39	v 1,06	v 0,68											
		hr 83,3	hr 28,1	hr 9,48	hr 3,90	hr 1,84	hr 0,96	hr 0,32											
150	2500	v 8,29	v 5,31	v 3,40	v 2,36	v 1,73	v 1,33	v 0,85											
		hr 126	hr 42,5	hr 14,3	hr 5,89	hr 2,78	hr 1,45	hr 0,49											
180	3000	v 6,37	v 4,08	v 2,83	v 2,08	v 1,59	v 1,02	v 0,71											
		hr 59,5	hr 20,1	hr 8,26	hr 3,90	hr 2,03	hr 0,69	hr 0,28											
210	3500	v 7,43	v 4,76	v 3,30	v 2,43	v 1,86	v 1,19	v 0,83											
		hr 79,1	hr 26,7	hr 11,0	hr 5,18	hr 2,71	hr 0,91	hr 0,38											
240	4000	v 8,49	v 5,44	v 3,77	v 2,77	v 2,12	v 1,36	v 0,94											
		hr 101	hr 34,2	hr 14,1	hr 6,64	hr 3,46	hr 1,17	hr 0,48											
300	5000	v 6,79	v 4,72	v 3,47	v 2,65	v 2,05	v 1,48	v 1,18											
		hr 51,6	hr 21,2	hr 10,0	hr 5,23	hr 1,77	hr 0,73	hr 0,27											
360	6000	v 8,15	v 5,66	v 4,16	v 3,18	v 2,47	v 1,82	v 1,42											
		hr 72,3	hr 29,8	hr 14,1	hr 7,33	hr 2,47	hr 1,02	hr 0,36											
420	7000	v 6,61	v 4,85	v 3,72	v 2,83	v 2,18	v 1,65	v 1,21											
		hr 39,6	hr 18,7	hr 9,75	hr 3,29	hr 1,35	hr 0,85	hr 0,31											
480	8000	v 7,55	v 5,55	v 4,2															

## FLOW RESISTANCE

### TABLE OF FLOW RESISTANCE IN BENDS, VALVES AND GATES

The flow resistance is calculated using the equivalent pipeline length method according to the table below:

ACCESSORY TYPE	DN											
	25	32	40	50	65	80	100	125	150	200	250	300
	Equivalent pipeline length (m)											
45° bend	0,2	0,2	0,4	0,4	0,6	0,6	0,9	1,1	1,5	1,9	2,4	2,8
90° bend	0,4	0,6	0,9	1,1	1,3	1,5	2,1	2,6	3,0	3,9	4,7	5,8
90° smooth bend	0,4	0,4	0,4	0,6	0,9	1,1	1,3	1,7	1,9	2,8	3,4	3,9
Union tee or cross	1,1	1,3	1,7	2,1	2,6	3,2	4,3	5,3	6,4	7,5	10,7	12,8
Gate	-	-	-	0,2	0,2	0,2	0,4	0,4	0,6	0,9	1,1	1,3
Non return valve	1,1	1,5	1,9	2,4	3,0	3,4	4,7	5,9	7,4	9,6	11,8	13,9

G-a-pcv\_a\_th

The table is valid for the Hazen Williams coefficient  $C = 100$  (cast iron pipework). For steel pipework, multiply the values by 1.41. For stainless steel, copper and coated cast iron pipework, multiply the values by 1.85.

When the **equivalent pipeline length** has been determined, the flow resistance is obtained from the table of flow resistance.

The values given are guideline values which are bound to vary slightly according to the model, especially for gate valves and non-return valves, for which it is a good idea to check the values supplied by the manufacturers.

## VOLUMETRIC CAPACITY

Litres per minute l/min	Cubic metres per hour m <sup>3</sup> /h	Cubic feet per hour ft <sup>3</sup> /h	Cubic feet per minute ft <sup>3</sup> /min	Imp. gal. per minute Imp. gal./min	US gal. per minute Us gal./min
<b>1,000</b>	0,0600	2,1189	0,0353	0,2200	0,2642
16,6667	<b>1,0000</b>	35,3147	0,5886	3,6662	4,4029
0,4719	0,0283	<b>1,0000</b>	0,0167	0,1038	0,1247
28,3168	1,6990	60,0000	<b>1,0000</b>	6,2288	7,4805
4,5461	0,2728	9,6326	0,1605	<b>1,0000</b>	1,2009
3,7854	0,2271	8,0208	0,1337	0,8327	<b>1,0000</b>

## PRESSURE AND HEAD

Newton per square metre N/m <sup>2</sup>	kilo Pascal kPa	bar bar	Pound force per square inch psi	metre of water m H <sub>2</sub> O	millimetre of mercury mm Hg
<b>1,0000</b>	0,0010	1 x 10 <sup>-5</sup>	1.45 x 10 <sup>-4</sup>	1.02 x 10 <sup>-4</sup>	0,0075
1000,0000	<b>1,0000</b>	0,0100	0,1450	0,1020	7,5006
1 x 10 <sup>5</sup>	100,0000	<b>1,0000</b>	14,5038	10,1972	750,0638
6894,7570	6,8948	0,0689	<b>1,0000</b>	0,7031	51,7151
9806,6500	9,8067	0,0981	1,4223	<b>1,0000</b>	73,5561
133,3220	0,1333	0,0013	0,0193	0,0136	<b>1,0000</b>

## LENGTH

millimetre mm	centimetre cm	metre m	inch in	foot ft	yard yd
<b>1,0000</b>	0,1000	0,0010	0,0394	0,0033	0,0011
10,0000	<b>1,0000</b>	0,0100	0,3937	0,0328	0,0109
1000,0000	100,0000	<b>1,0000</b>	39,3701	3,2808	1,0936
25,4000	2,5400	0,0254	<b>1,0000</b>	0,0833	0,0278
304,8000	30,4800	0,3048	12,0000	<b>1,0000</b>	0,3333
914,4000	91,4400	0,9144	36,0000	3,0000	<b>1,0000</b>

## VOLUME

cubic metre m <sup>3</sup>	litre litro	millilitre ml	imp. Gallon imp. gal.	US gallon US gal.	cubic foot ft <sup>3</sup>
<b>1,0000</b>	1000,0000	1 x 10 <sup>6</sup>	219,9694	264,1720	35,3147
0,0010	<b>1,0000</b>	1000,0000	0,2200	0,2642	0,0353
1 x 10 <sup>-6</sup>	0,0010	<b>1,0000</b>	2.2 x 10 <sup>-4</sup>	2.642 x 10 <sup>-4</sup>	3.53 x 10 <sup>-5</sup>
0,0045	4,5461	4546,0870	<b>1,0000</b>	1,2009	0,1605
0,0038	3,7854	3785,4120	0,8327	<b>1,0000</b>	0,1337
0,0283	28,3168	28316,8466	6,2288	7,4805	<b>1,0000</b>

G-at\_pp-en\_a\_sc

# Xylem |'zīləm|

- 1) The tissue in plants that brings water upward from the roots;
- 2) a leading global water technology company.

We're 12,000 people unified in a common purpose: creating innovative solutions to meet our world's water needs. Developing new technologies that will improve the way water is used, conserved, and re-used in the future is central to our work. We move, treat, analyze, and return water to the environment, and we help people use water efficiently, in their homes, buildings, factories and farms. In more than 150 countries, we have strong, long-standing relationships with customers who know us for our powerful combination of leading product brands and applications expertise, backed by a legacy of innovation.

**For more information on how Xylem can help you, go to [xylem.com](http://xylem.com).**



Headquarters

XYLEM WATER SYSTEMS USA LLC

1 Goulds Drive

Auburn, NY 13021 - U.S.A.

Phone: +1 (800) 453-6777

Fax: +1 (888) 322-5877

Goulds is a registered trademark of Goulds Pumps, Inc and is used under license.  
© 2012 Xylem Inc.