



Pompe da drenaggio per liquidi carichi con girante arretrata di tipo Vortex per applicazioni civili e industriali; sono state particolarmente progettate per uso estremamente gravoso; disponibili sia per applicazioni mobili e fissa con piede di accoppiamento.

Drainage pump for charged liquids with set-back Vortex type impeller for civil and industrial applications; specifically designed for very heavy use; available in the mobile or permanent versions with coupling feet.

Bombas de drenaje para líquidos cargados con turbina retráida de tipo Vortex para aplicaciones civiles e industriales; se han proyectado especialmente para un uso gravoso; disponibles para aplicaciones móviles y fija con pie de acoplamiento.

Pompes de drainage pour liquides chargés avec roue décalée de type Vortex, pour applications civiles et industrielles; elles ont été spécialement conçues pour un service très intense; disponibles pour applications aussi bien mobiles que fixes, avec pied d'accouplement.

TYPE	TRUCK		CONTAINER	
	PALLET (cm)	N° pumps	PALLET (cm)	N° pumps
DV 160-310	85X110X145	18	85X110X190	27
DVT 400-550	85X110X170	12	85X110X170	12
DVT 750-1000	100X120190	12	100X120190	12

**CARATTERISTICHE COSTRUTTIVE / CONSTRUCTION FEATURES  
CARACTERÍSTICAS CONSTRUCTIVAS / CARACTÉRISTIQUES D'EXÉCUTION**

<b>Corpo pompa</b> <b>Pump body</b> <b>Cuerpo bomba</b> <b>Corps de pompe</b>	ghisa cast iron fundición fonte
<b>Girante</b> <b>Impeller</b> <b>Rodete</b> <b>Turbine</b>	ghisa cast iron fundición fonte
<b>Tenuta meccanica</b>	doppia tenuta con barriera d'olio:carburo di silicio lato pompa, ceramica-grafite lato motore
<b>Mechanical seal</b>	double seal with oil barrier: silicon carbide on pump side, ceramic-graphite on motor side
<b>Sello mecánico</b>	doble sello con cámara interpuesta:carburo de silicio lado bomba, cerámica-grafito lado motor
<b>Garniture mécanique</b>	double garniture avec film lubrifiant:carbure de silice côté pompe, céramique-graphite côté moteur
<b>Albero motore</b> <b>Motor shaft</b> <b>Eje motor</b> <b>Arbre moteur</b>	acciaio AISI 304 stainless steel AISI 304 acero AISI 304 acier AISI 304
<b>Passaggio corpi solidi</b> <b>Passage of solids</b> <b>Paso de solidos</b> <b>Passage corps solides</b>	50 mm (DV160-310; 750-1000) 45 mm (DV400-550)
<b>Profondità di immersione</b> <b>Depth of immersion</b> <b>Profundidad inmersión</b> <b>Profondeur immersion</b>	max 20 m
<b>Temperatura del liquido</b> <b>Liquid temperature</b> <b>Temperatura del liquido</b> <b>Température du liquide</b>	0 - 40 °C
<b>Cavo</b> <b>Cable</b> <b>Cable</b> <b>Câble</b>	H07 RNF, 10 m
<b>Viteria</b> <b>Bolts</b> <b>Tornillos</b> <b>Vis</b>	acciaio inossidabile A2 A2 stainless steel acero A2 acier A2
<b>Base appoggio</b> <b>Foot support</b> <b>Placa base</b> <b>Plaque de base</b>	ferro zincato galvanized iron hierro galvanizado fer galvanisé
<b>Guarnizioni</b> <b>Gaskets</b> <b>Anillos</b> <b>Joints</b>	gomma NBR NBR rubber goma NBR caoutchouc NBR
<b>MOTORE / MOTOR / MOTOR / MOTEUR</b>	
<b>Motore 2 poli a induzione in bagno d'olio</b> <b>2 pole induction motor in oil bath</b>	3~ 220/380V - 60Hz 1~ 220V - 60Hz necessario condensatore d'avviamento (35µF per modello da 1,5HP, 50µF per modello da 2HP) required starter capacitor (35µF for 1,5HP model, 50µF for 2HP model)
<b>Motor de 2 polos a inducción en baño de caeite</b>	necesario condensador de arranque (35µF para modelo 1,5HP, 50µF para modelo 2HP)
<b>Moteur à induction à 2 pôles en bain d'huile</b>	nécessaires condensateur de démarrage (35µF pour modèle 1,5HP, 50µF pour modèle 2HP)
<b>Classe di isolamento</b> <b>Insulation class</b> <b>Clase de aislamiento</b> <b>Classe d'isolation</b>	F
<b>Grado di protezione</b> <b>Protection degree</b> <b>Grado de protección</b> <b>Protection</b>	IP68

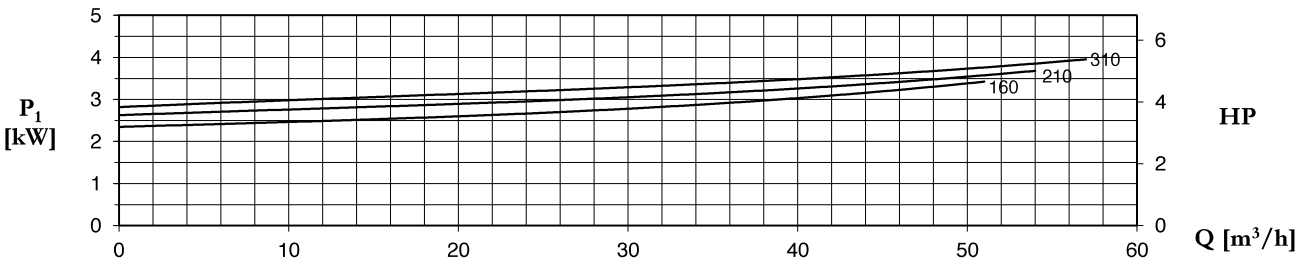
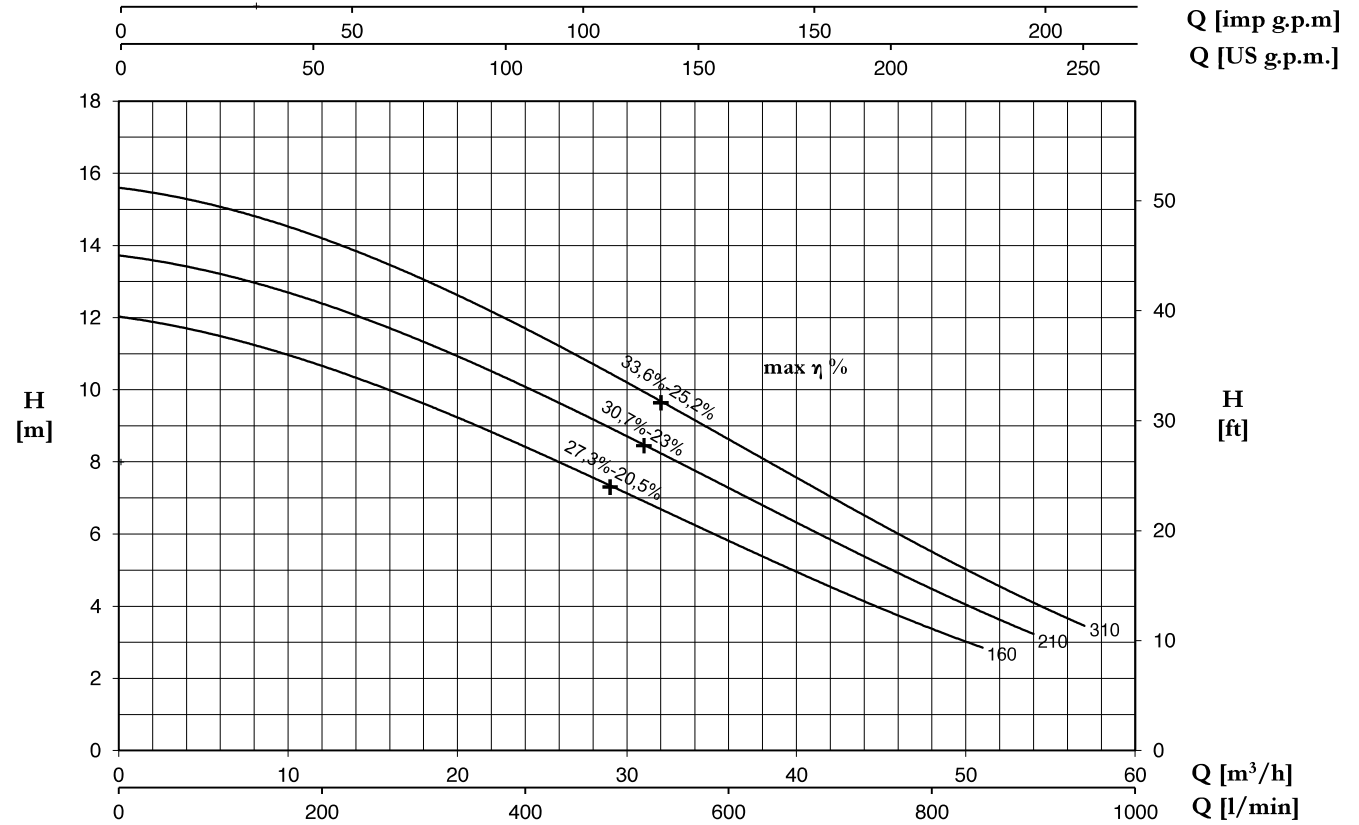

TYPE		AMPERE			
1~	3~	220 V 60 Hz	3x220 V 60 Hz	3x380 V 60 Hz (*)	220/380 V 60 Hz Λ / Δ
DV 160	DVT 160	15,7	9,1	5,3	-
DV 210	DVT 210	17,2	11,0	6,4	-
-	DVT 310	-	12,3	7,1	-

+ max  $\eta$  %

max rendimento idraulico e rispettivo rendimento totale  
max hydraulic efficiency and respective total efficiency  
máx rendimiento hidráulico y correspondiente rendimiento total  
max rendement hydraulique et rendement total

(\*) no standard execution

TYPE		P2		P1 (kW)		Q (m <sup>3</sup> /h - l/min)							
1~	3~	(HP)	(kW)	1~	3~	0	12	24	36	48	51	54	57
						0	200	400	600	800	850	900	950
						H (m)							
DV 160	DVT 160	1,5	1,1	3,4	3	12,0	10,7	8,3	5,9	3,4	2,8	-	-
DV 210	DVT 210	2	1,5	3,7	3,6	13,7	12,5	9,9	7,3	4,5	3,8	3,2	-
-	DVT 310	3	2,2	-	3,9	15,6	14,2	11,6	8,7	5,5	4,8	4,1	3,5

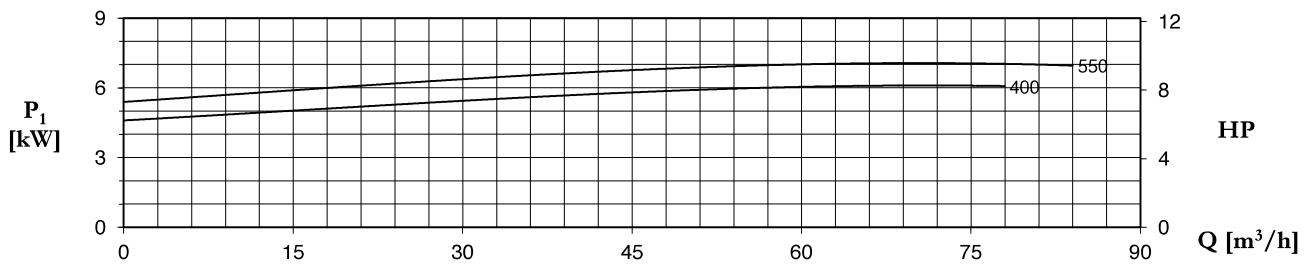
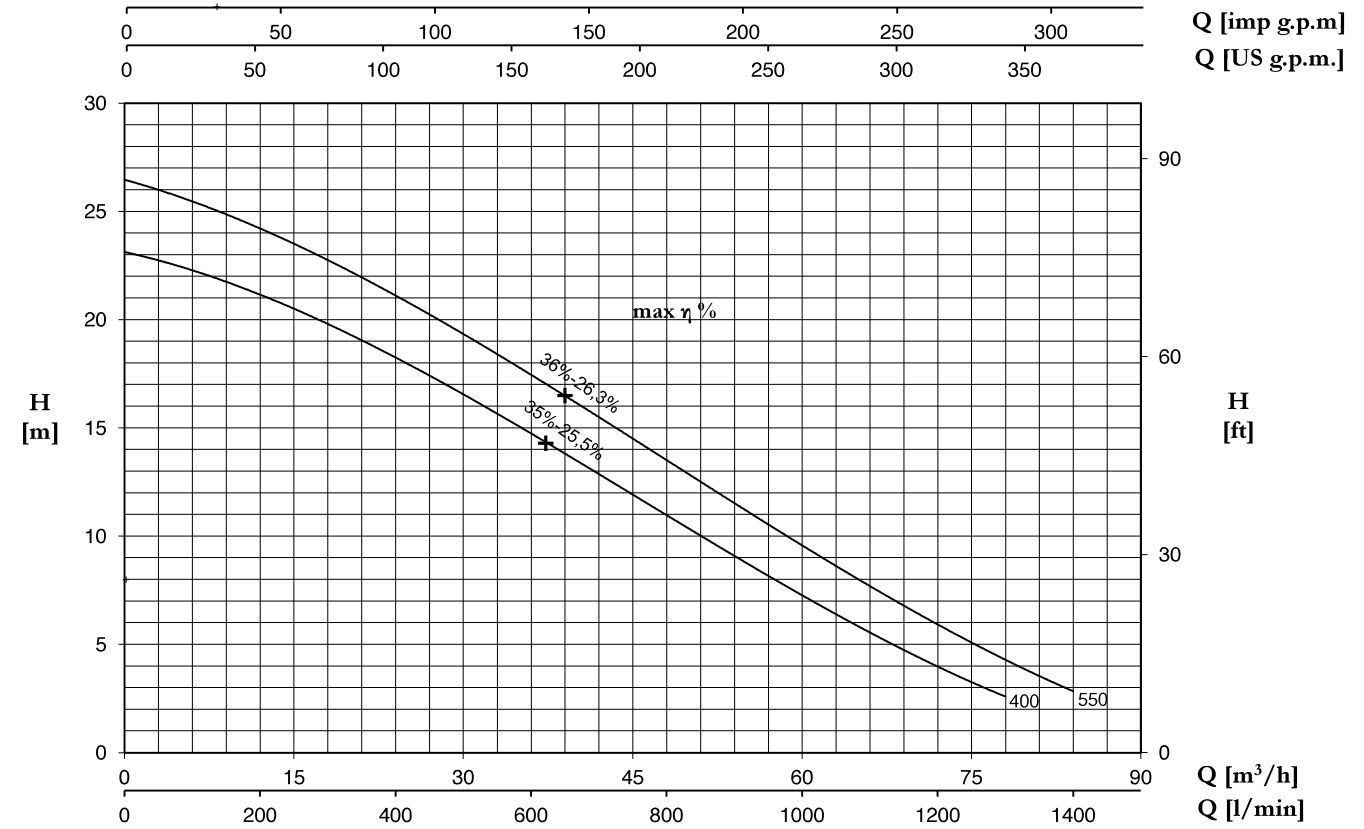

TYPE	AMPERE		
	3x220 V 60 Hz	3x380 V 60 Hz (*)	220/380 V 60 Hz $\lambda / \Delta$
DVT 400	18,40	10,6	-
DVT 550	22,00	12,7	-

+ max  $\eta$  %

max rendimento idraulico e rispettivo rendimento totale  
max hydraulic efficiency and respective total efficiency  
máx rendimiento hidráulico y correspondiente rendimiento total  
max rendement hydraulique et rendement total

TYPE	P2		P1 (kW)	Q (m³/h - l/min)									
				0	12	24	36	48	60	72	78	84	
	(HP)	(kW)	3~	0	200	400	600	800	1000	1200	1300	1400	
DVT 400	4	3	6,2	23,1	21,2	18,3	14,7	10,9	7,3	4,1	2,5	-	
DVT 550	5,5	4	7,2	26,4	24,4	21,0	17,4	13,6	9,5	6,0	4,3	2,8	

Q [imp g.p.m.]  
Q [US g.p.m.]

Q [m³/h]  
Q [l/min]

HP  
Q [m³/h]

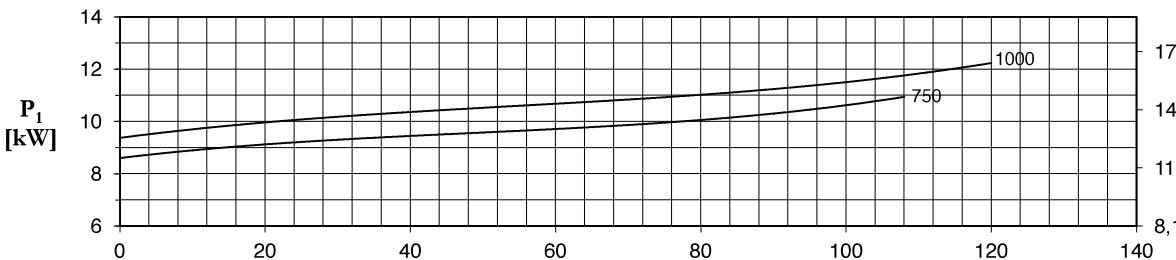
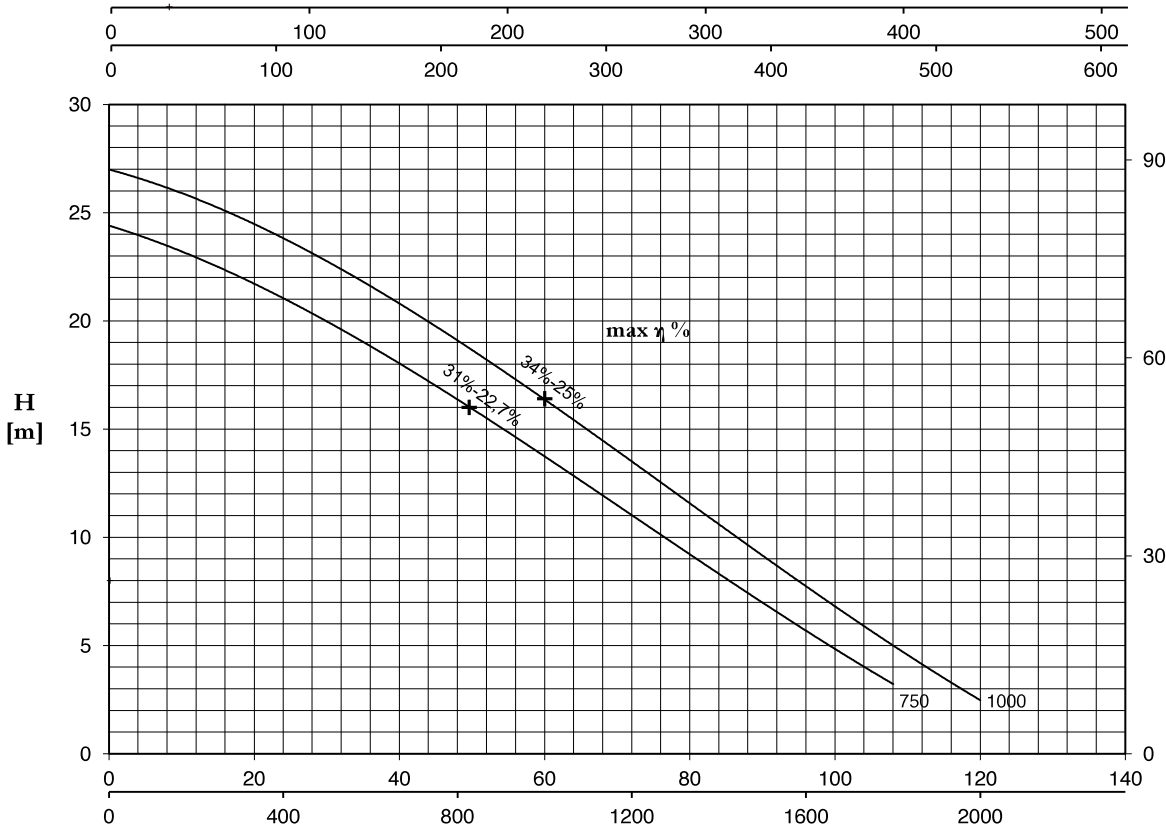

TYPE	AMPERE		
	3x220 V 60 Hz	3x380 V 60 Hz (*)	220/380 V 60 Hz Λ / Δ
DVT 750	-	19,7	34,1
DVT 1000	-	21,4	37,0

+ max η %

max rendimento idraulico e rispettivo rendimento totale  
max hydraulic efficiency and respective total efficiency  
máx rendimiento hidráulico y correspondiente rendimiento total  
max rendement hydraulique et rendement total

(\*) no standard execution

TYPE	P2		P1 (kW)	Q (m³/h - l/min)											
				0	12	24	36	48	60	72	84	96	108	114	120
				0	200	400	600	800	1000	1200	1400	1600	1800	1900	2000
3~	(HP)	(kW)	3~	H (m)											
DVT 750	7,5	5,5	11,0	24,4	23,0	21,0	18,7	16,4	13,9	11,1	8,2	5,6	3,3	2,2	-
DVT 1000	10	7,5	12,3	27,1	25,5	23,8	21,6	19,1	16,4	13,7	10,6	7,6	4,9	3,7	2,6

**DV**

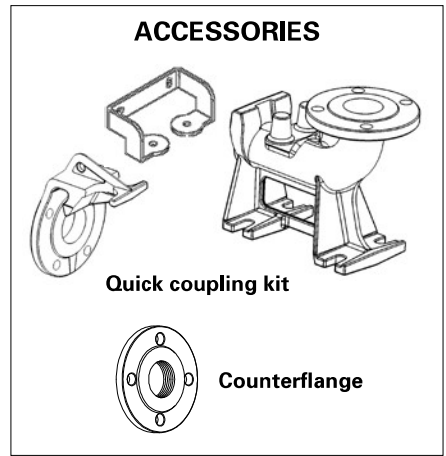
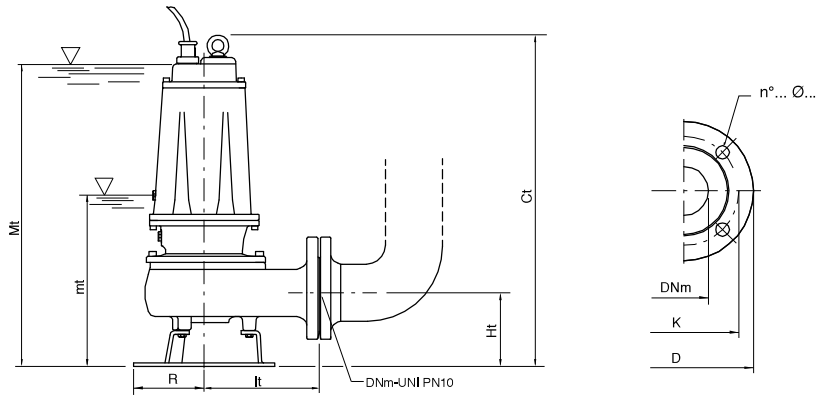

TYPE	DIMENSIONS (mm)							Kg
	Ct	Ht	R	lt	mt	Mt	DNm	
DVT 160	551	123	117	191	243	513	65	39
DV 160-DVT 210	551	123	117	191	243	513	65	40
DV 210-DVT 310	551	123	117	191	243	513	65	42,5
DVT 400	645	148	160	210	285	600	80	69,2
DVT 550	645	148	160	210	285	600	80	72,5
DVT 750	725	178	180	232	358	670	80	91,5
DVT 1000	725	178	180	232	358	670	80	93,2

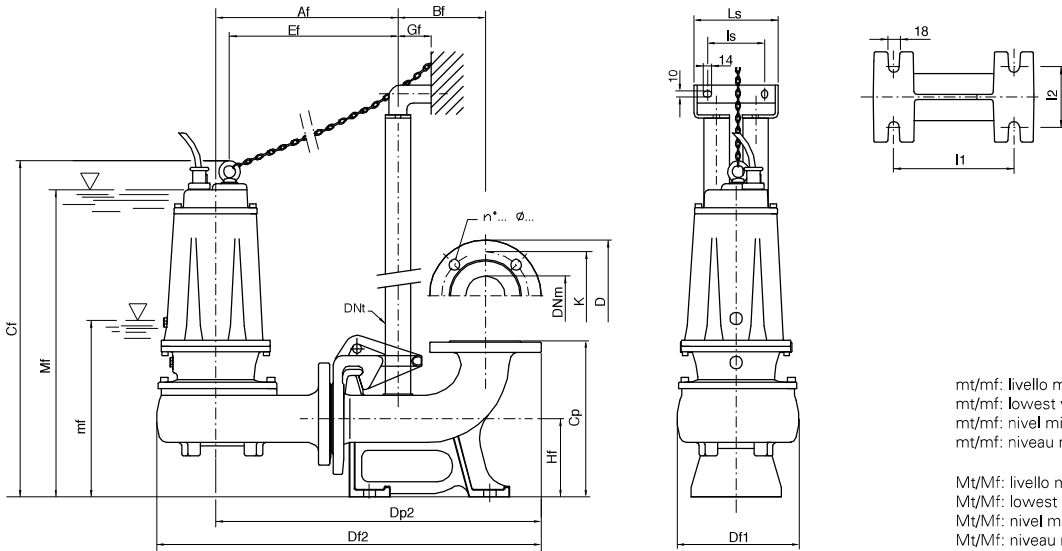

mt/mf: livello minimo di funzionamento  
 mt/mf: lowest working level  
 mt/mf: nivel minimo de funcionamiento  
 mt/mf: niveau minimum de fonctionnement

Mt/Mf: livello minimo di funzionamento continuo  
 Mt/Mf: lowest level for continuous duty  
 Mt/Mf: nivel minimo de funcionamiento continuo  
 Mt/Mf: niveau minimum de fonctionnement continuu

TYPE	DIMENSIONS (mm)																	
	Af	Bf	Cf	Cp	Df1	Df2	Dp2	DNt	Ef	Gf	Hf	l1	l2	l3	Ls	mf	Mf	DNm
DVT 160 /P	303	145	559	260	200	639	541	1" 1/4	280	55	130	200	100	95	140	251	521	65
DV 160-DVT 210/P	303	145	559	260	200	639	541	1" 1/4	280	55	130	200	100	95	140	251	521	65
DV 210-DVT 310/P	303	145	559	260	200	639	541	1" 1/4	280	55	130	200	100	95	140	251	521	65
DVT 400/P	350	165	690	340	220	720	615	2"	319	85	190	250	140	130	180	327	642	80
DVT 550/P	350	165	690	340	220	720	615	2"	319	85	190	250	140	130	180	327	642	80
DVT 750/P	370	165	745	340	235	750	638	2"	338	85	190	250	140	130	180	380	690	80
DVT 1000/P	370	165	745	340	235	750	638	2"	338	85	190	250	140	130	180	380	690	80

Flange UNI PN 10 (mm)			
DNm	K	D	n°... Ø...
65	145	185	4... 18...
80	160	200	8... 18...