

VX 40 - VX 50 - VX 65

VORTEX

Submersible pumps

 Sewage water

 Civil use

 Industrial use



PERFORMANCE RANGE

- Flow rate up to **1400 l/min** (84 m³/h)
- Head up to **27.5 m**

APPLICATION LIMITS

- **10 m** maximum immersion depth (with a sufficiently long power cable)
- Maximum liquid temperature **+40 °C**
- Passage of solids:
 - up to **Ø 40 mm** for VX 40
 - up to **Ø 50 mm** for VX 50
 - up to **Ø 65 mm** for VX 65
- Minimum immersion depth for continuous service **500 mm**

CONSTRUCTION AND SAFETY STANDARDS

- **10 m** long power cable

EN 60335-1
IEC 60335-1
CEI 61-150

EN 60034-1
IEC 60034-1
CEI 2-3



CERTIFICATIONS

Company with management system certified DNV
ISO 9001: QUALITY

INSTALLATION AND USE

The **VX 40, VX 50 and VX 65** series of pumps, manufactured from stainless steel and heavy gauge robust cast iron, resistant to abrasion and long-lasting, are fitted with a VORTEX impeller and are therefore suitable for draining **dirty, sewage and reflux water, and water mixed with putrid mud**. They are suitable for installation in sewers, tunnels, excavations, canals, underground car parks, etc.

PATENTS - TRADE MARKS - MODELS

- Registered EU Design n. 003863158-0002

OPTIONS AVAILABLE ON REQUEST

- Pump body with NPT ANSI B 1.20.1 threaded ports
- Other voltages

GUARANTEE

2 years subject to terms and conditions

CHARACTERISTIC CURVES AND PERFORMANCE DATA

60 Hz n= 3450 min⁻¹

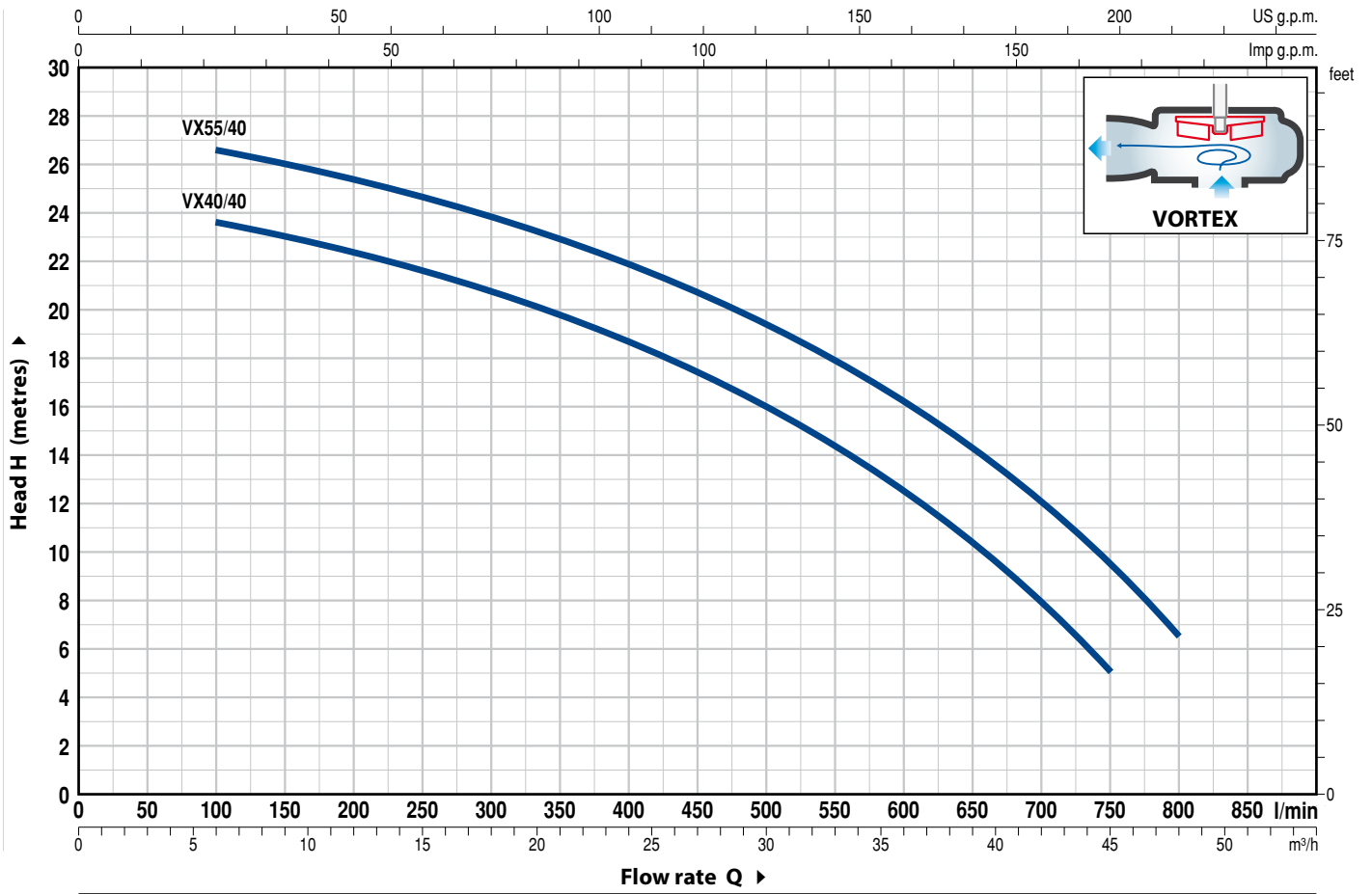

MODEL	POWER (P ₂)		Q	Flow rate											
	kW	HP		m ³ /h	0	6	12	18	24	30	36	42	45	48	
Three-phase				0	100	200	300	400	500	600	700	750	800		
VX40/40	3	4	H metres	24.5	23.5	22.3	20.8	18.7	16	12.4	7.7	5			
VX 55/40	4	5.5	H metres	27.5	26.5	25.3	23.8	21.9	19.4	16.1	11.8	9.3	6.5		

Q = Flow rate H = Total manometric head

Tolerance of characteristic curves in compliance with EN ISO 9906 Grade 3B.

VX 50

CHARACTERISTIC CURVES AND PERFORMANCE DATA

60 Hz n= 3450 min⁻¹

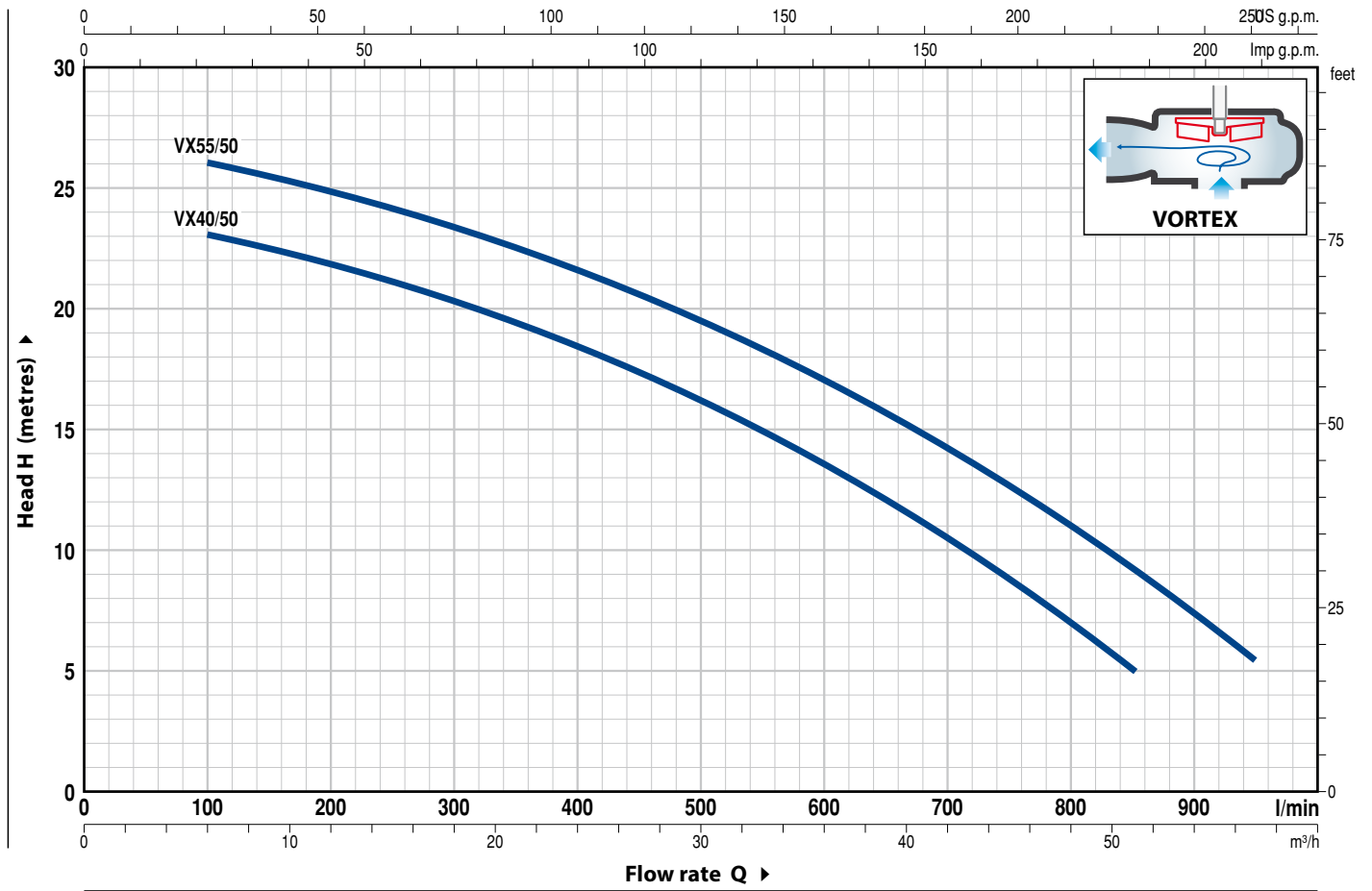

MODEL Three-phase	POWER (P ₂)		Q	0	6	12	18	24	30	36	42	48	51	57
	kW	HP		0	100	200	300	400	500	600	700	800	850	950
VX 40/50	3	4	H metres	24	23	21.8	20.3	18.4	16.1	13.4	10.3	6.9	5	
VX 55/50	4	5.5	H metres	27	26	25	23.4	21.6	19.4	16.9	14	10.9	9.2	5.5

Q = Flow rate H = Total manometric head

Tolerance of characteristic curves in compliance with EN ISO 9906 Grade 3B.

CHARACTERISTIC CURVES AND PERFORMANCE DATA

60 Hz n= 3450 min⁻¹

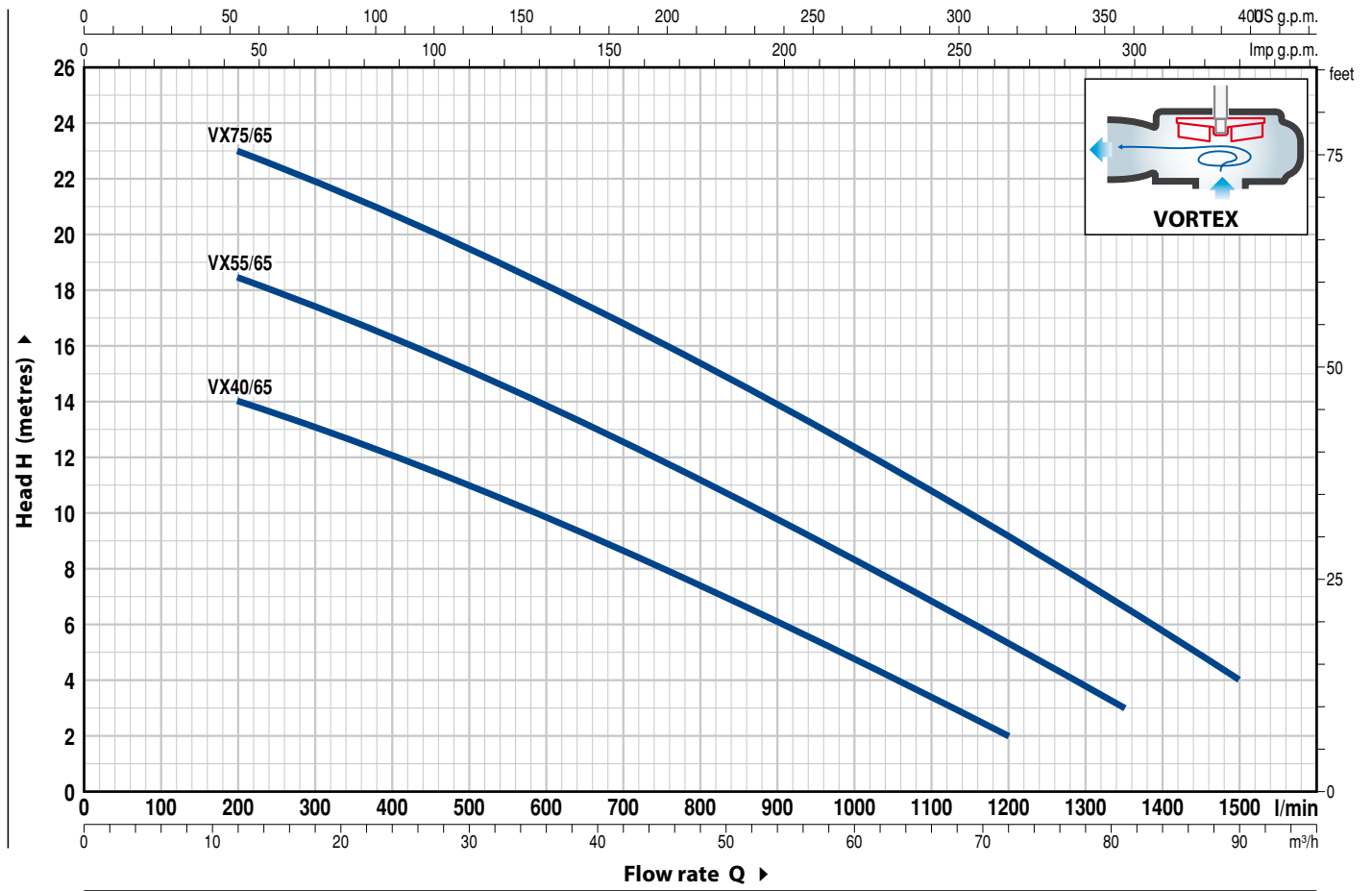

MODEL Three-phase	POWER (P ₂)		Q	Flow rate													
	kW	HP		0	12	18	27	36	45	54	63	72	81	90			
VX 40/65	3	4	H metres	0	200	300	450	600	750	900	1050	1200	1350	1500			
VX 55/65	4	5.5		15.7	14	13.1	11.6	9.9	8.1	6.2	4.2	2					
VX 75/65	5.5	7.5		20.3	18.5	17.5	15.7	13.8	11.8	9.7	7.5	5.3	3				
				25.0	23.0	21.9	20.1	18.2	16.0	13.8	11.5	9.1	6.6	4.0			

Q = Flow rate H = Total manometric head

Tolerance of characteristic curves in compliance with EN ISO 9906 Grade 3B.

POS. COMPONENT CONSTRUCTION CHARACTERISTICS

1 PUMP BODY	Cast iron with an Epoxy Electro Coating treatment, with threaded port in compliance with ISO 228/1				
2 IMPELLER	VORTEX type in cast iron with an Epoxy Electro Coating treatment				
3 MOTOR CASING	Stainless steel AISI 304				
4 MOTOR CASING PLATE	Cast iron with an Epoxy Electro Coating treatment				
5 MOTOR SHAFT	Stainless steel AISI 431				
6 TWO MECHANICAL SEALS SEPARATED BY AN OIL CHAMBER					
<i>Seal Model</i>	<i>Shaft Diameter</i>	<i>Position</i>	<i>Stationary ring</i>	<i>Rotational ring</i>	<i>Elastomer</i>
ED560-25	Ø 25 mm	Motor side Pump side	Silicon carbide Silicon carbide	Graphite Silicon carbide	NBR NBR
7 BEARINGS	6306 ZZ C3 / 6304 ZZ C3				
8 ELECTRIC MOTOR	Three-phase 380 V - 60 Hz <u>with thermal overload protector incorporated into the winding</u> – Insulation: class F – Protection: IP X8				
9 POWER CABLE	Type "H07 RN-F" Standard length 10 metres				

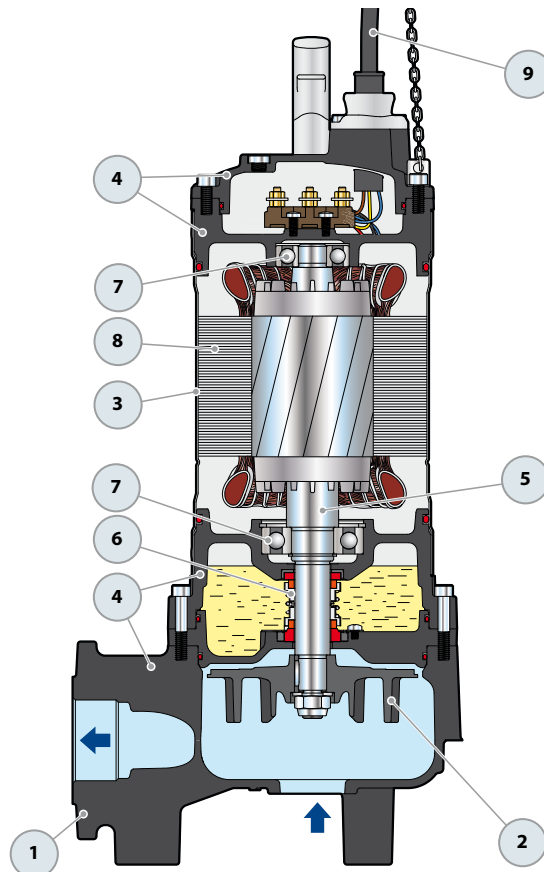

DIMENSIONS AND WEIGHT

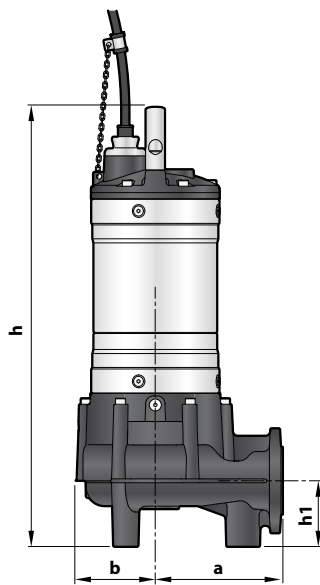

Standard installation

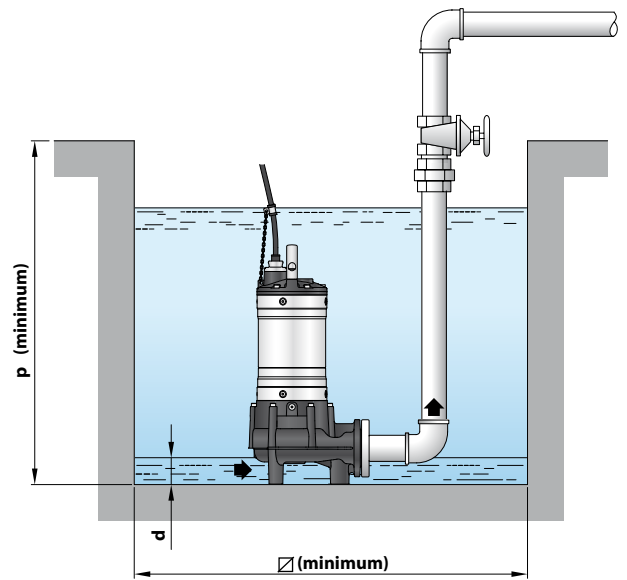

MODEL	Passage of solids	DIMENSIONS mm								kg
		a	b	c	h	h1	d	p	Ø	
Three-phase										3~
VX 40/40	Ø 40 mm	170	107	192	587	88	55	700	500	48.3
VX 55/40					627					54.3

FLANGED PORT

MODEL	FLANGE DN	F	K mm	D mm	HOLES	
					N.	Ø (mm)
VX 40/40	50 (PN6)	2"	110	140	4	14
VX 55/40						

ABSORPTION

MODEL	VOLTAGE		
	220 V	380 V	440 V
Three-phase			
VX 40/40	12.9 A	6.9 A	6.0 A
VX 55/40	12.5 A	8.2 A	7.1 A

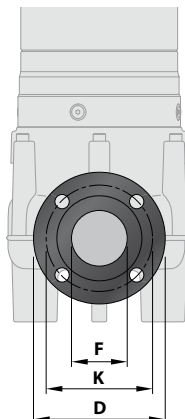

PALLETIZATION

MODEL	GROUPAGE
Three-phase	n. pumps
VX 40/40	10
VX 55/40	10

POS. COMPONENT CONSTRUCTION CHARACTERISTICS

1 PUMP BODY	Cast iron with an Epoxy Electro Coating treatment, with threaded port in compliance with ISO 228/1				
2 IMPELLER	VORTEX type in cast iron with an Epoxy Electro Coating treatment				
3 MOTOR CASING	Stainless steel AISI 304				
4 MOTOR CASING PLATE	Cast iron with an Epoxy Electro Coating treatment				
5 MOTOR SHAFT	Stainless steel AISI 431				
6 TWO MECHANICAL SEALS SEPARATED BY AN OIL CHAMBER					
<i>Seal Model</i>	<i>Shaft Diameter</i>	<i>Position</i>	<i>Stationary ring</i>	<i>Rotational ring</i>	<i>Elastomer</i>
ED560-25	Ø 25 mm	Motor side Pump side	Silicon carbide Silicon carbide	Graphite Silicon carbide	NBR NBR
7 BEARINGS	6306 ZZ C3 / 6304 ZZ C3				
8 ELECTRIC MOTOR	Three-phase 380 V - 60 Hz <u>with thermal overload protector incorporated into the winding</u> – Insulation: class F – Protection: IP X8				
9 POWER CABLE	H07 RN-F" type Standard length 10 metres				

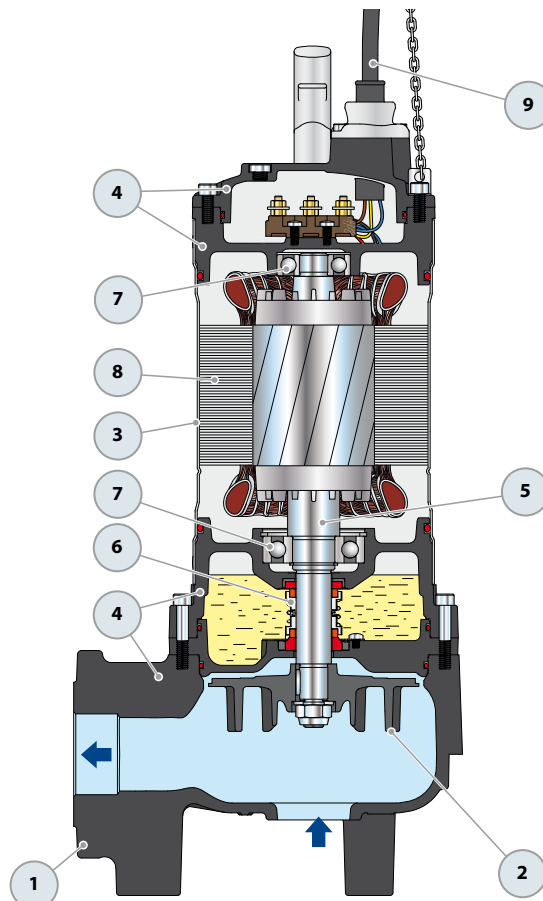

DIMENSIONS AND WEIGHT

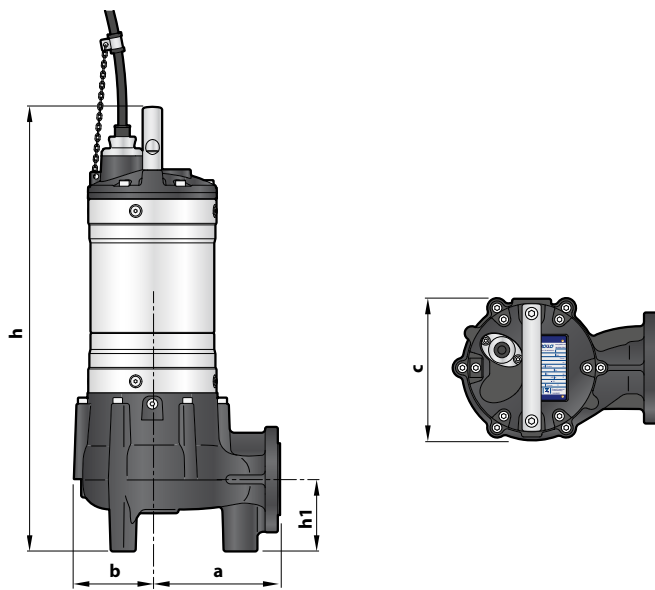

Standard installation

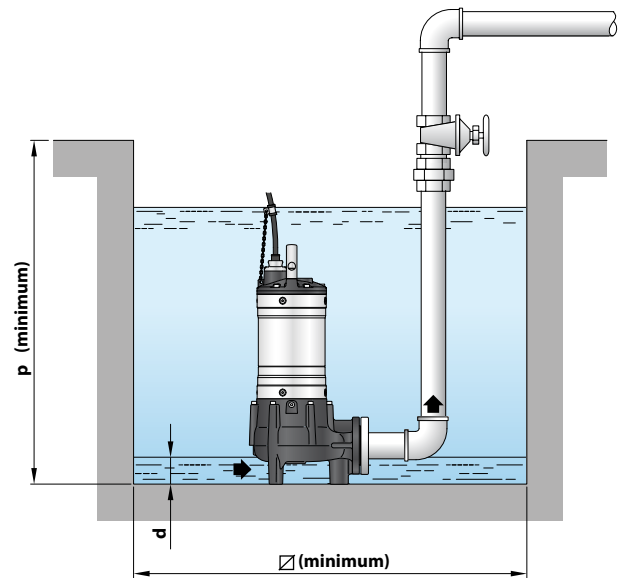

MODEL	Passage of solids	DIMENSIONS mm								kg
		a	b	c	h	h1	d	p	\varnothing	
Three-phase										3~
VX 40/50	\varnothing 50 mm	170	106	193	602	100	55	700	500	50.0
VX 55/50					642					58.2

FLANGED PORT

MODEL	FLANGE DN	F	K mm	D mm	HOLES	
					N.	\varnothing (mm)
VX 40/50	50 (PN10)	2"	125	150	4	18
VX 55/50						

ABSORPTION

MODEL	VOLTAGE		
	220 V	380 V	440 V
Three-phase			
VX 40/50	12.0 A	6.9 A	6.0 A
VX 55/50	14.2 A	8.2 A	7.1 A

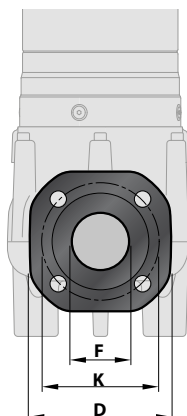

PALLETIZATION

MODEL	GROUPAGE
Three-phase	n. pumps
VX 40/50	10
VX 55/50	12

POS. COMPONENT CONSTRUCTION CHARACTERISTICS

1	PUMP BODY	Cast iron with an Epoxy Electro Coating treatment, with threaded port in compliance with ISO 228/1				
2	IMPELLER	VORTEX type in cast iron with an Epoxy Electro Coating treatment				
3	MOTOR CASING	Stainless steel AISI 304				
4	MOTOR CASING PLATE	Cast iron with an Epoxy Electro Coating treatment				
5	MOTOR SHAFT	Stainless steel AISI 431				
6	TWO MECHANICAL SEALS SEPARATED BY AN OIL CHAMBER					
	<i>Seal</i>	<i>Shaft</i>	<i>Position</i>	<i>Materials</i>		
	<i>Model</i>	<i>Diameter</i>		<i>Stationary ring</i>	<i>Rotational ring</i>	<i>Elastomer</i>
	AR-27	Ø 27 mm	Motor side	Silicon carbide	Graphite	NBR
	AR-25	Ø 25 mm	Pump side	Silicon carbide	Silicon carbide	NBR
7	BEARINGS	6306 ZZ C3 / 6304 ZZ C3				
8	ELECTRIC MOTOR	Three-phase 380 V - 60 Hz <u>with thermal overload protector incorporated into the winding</u> – Insulation: class F – Protection: IP X8				
9	POWER CABLE	"H07 RN-F" type Standard length 10 metres				

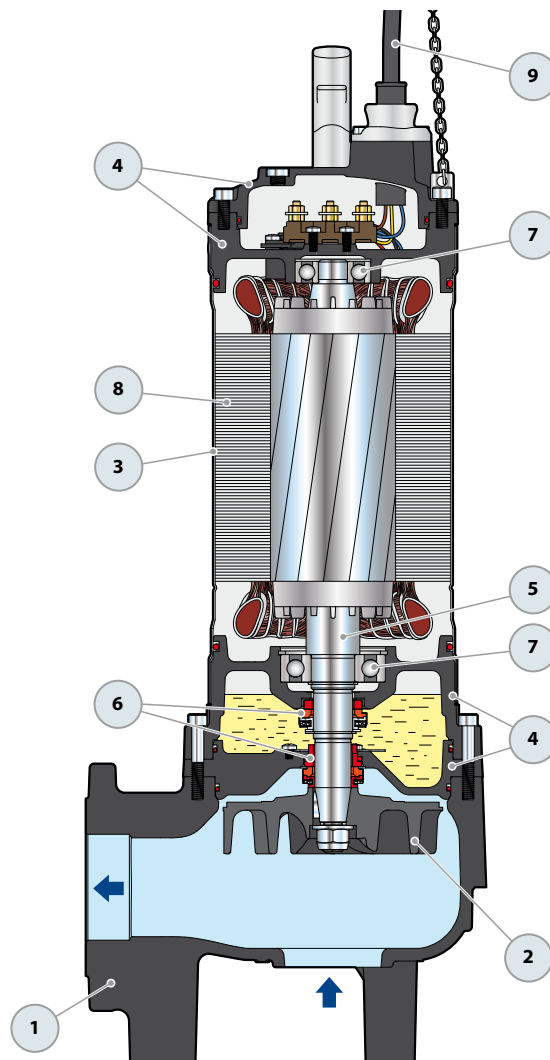

DIMENSIONS AND WEIGHT

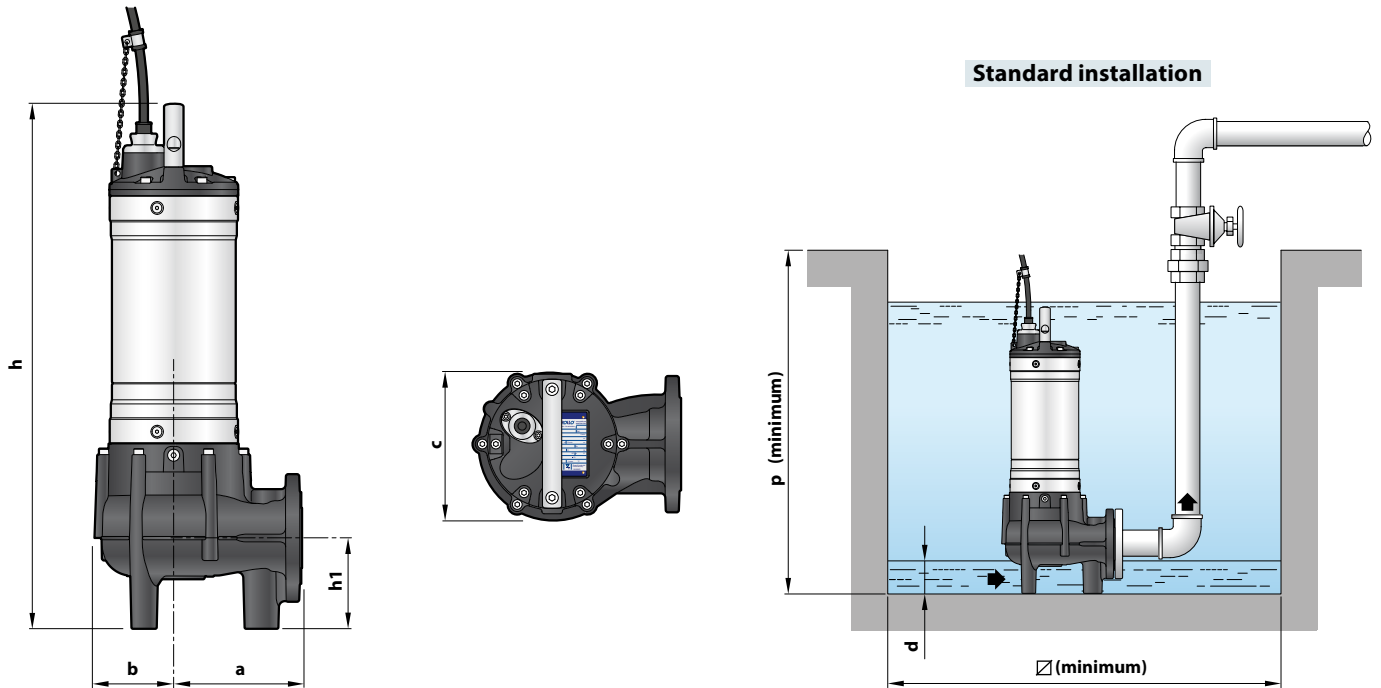

MODEL	Passage of solids	DIMENSIONS mm								3~
		a	b	c	h	h1	d	p	∅	
Three-phase										
VX 40/65	Ø 65 mm	170	107	196	630	121	70	800	500	53.3
VX 55/65					670					60.0
VX 75/65					700					65.0

FLANGED PORT

MODEL	FLANGE DN	F	K mm	D mm	HOLES	
					N.	∅ (mm)
Three-phase						
VX 40/65	65 (PN10)	2½"	145	185	8	18
VX 55/65						
VX 75/65						

ABSORPTION

MODEL	VOLTAGE		
	220 V	380 V	440 V
Three-phase			
VX 40/65	12.0 A	6.9 A	6.0 A
VX 55/65	16.3 A	9.4 A	8.2 A
VX 75/65	23.9 A	13.8 A	12.0 A

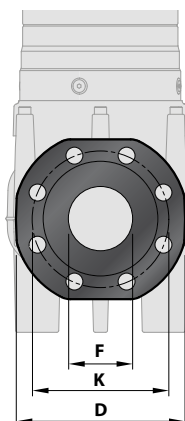

PALLETIZATION

MODEL	GROUPAGE
Three-phase	n. pumps
VX 40/65	12
VX 55/65	12
VX 75/65	12

SEWAGE LIFTING SYSTEM VX40 – VX50 – VX65 – BC35

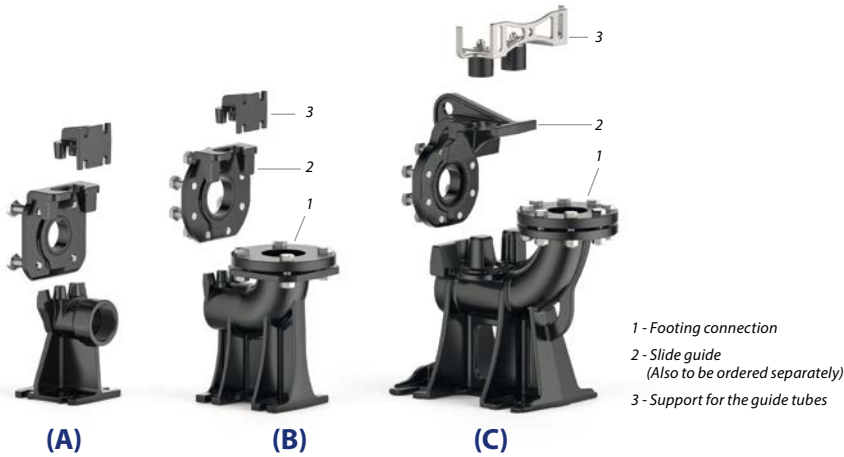

1 - Footing connection
2 - Slide guide
(Also to be ordered separately)
3 - Support for the guide tubes



A) HORIZONTAL DELIVERY VERSION WITH 3/4" GUIDE TUBES

For VX /40	Cod. ASSPVX40	DN 2"
For VX /50	Cod. ASSPVX50	DN 2"

Kit consisting of:

- footing connection
- slide guide with screws and seals
- support for the guide tubes

B) VERTICAL DELIVERY VERSION WITH 3/4" GUIDE TUBES

For VX /40	Cod. ASSPVX40V	DN 2 1/2"
For VX /50	Cod. ASSPVX503V	DN 2 1/2"
For VX /65, BC /35	Cod. ASSPVX653V	DN 3"

Kit consisting of:

- footing connection complete with counterflange
- slide guide with screws and seals
- support for the guide tubes

C) VERTICAL DELIVERY VERSION WITH 2" GUIDE TUBES

For VX /50	Cod. ASSPVX50V	DN 3"
For VX /50, VX /65, BC /35	Cod. ASSPVX65V	DN 3"

Kit consisting of:

- footing connection complete with counterflange
- slide guide with screws and seals
- support for the guide tubes

SLIDE GUIDE (Also to be ordered separately)

For VX /40 with guide tubes \varnothing 3/4"	Cod. ASSFL011
For VX /50 with guide tubes \varnothing 3/4"	Cod. ASSFL009
For VX /50 with guide tubes \varnothing 2"	Cod. ASSFL050
For VX /65, BC /35 with guide tubes \varnothing 3/4"	Cod. ASSFL010
For VX /65, BC /35 with guide tubes \varnothing 2"	Cod. ASSFL065

Complete with screws and seals

● INTERMEDIATE SUPPORT (To be ordered separately)

For guide tubes \varnothing 3/4"	Cod. 859SV340INTFA
For guide tubes \varnothing 2"	Cod. 859SV349INTFA



In order to ensure stability, insert the intermediate support:

- every 2 metres with 3/4" guide tubes (compulsory)
- every 3 metres with 2" guide tubes (recommended)

GUIDE TUBES (AISI 304 stainless steel)

Guide tube \varnothing 3/4"	Cod. 54SARTG005
Guide tube \varnothing 2"	Cod. 54SARTG006

Maximum length of the tube plank: 6 metres

STANDARD INSTALLATION

1. Pump
2. Footing connection
3. Guide tubes
4. Support for the guide tubes
5. Lifting chain
6. Control box
7. Alarm float switch
8. Starting float switch
9. Stop float switch
10. Non-return valve

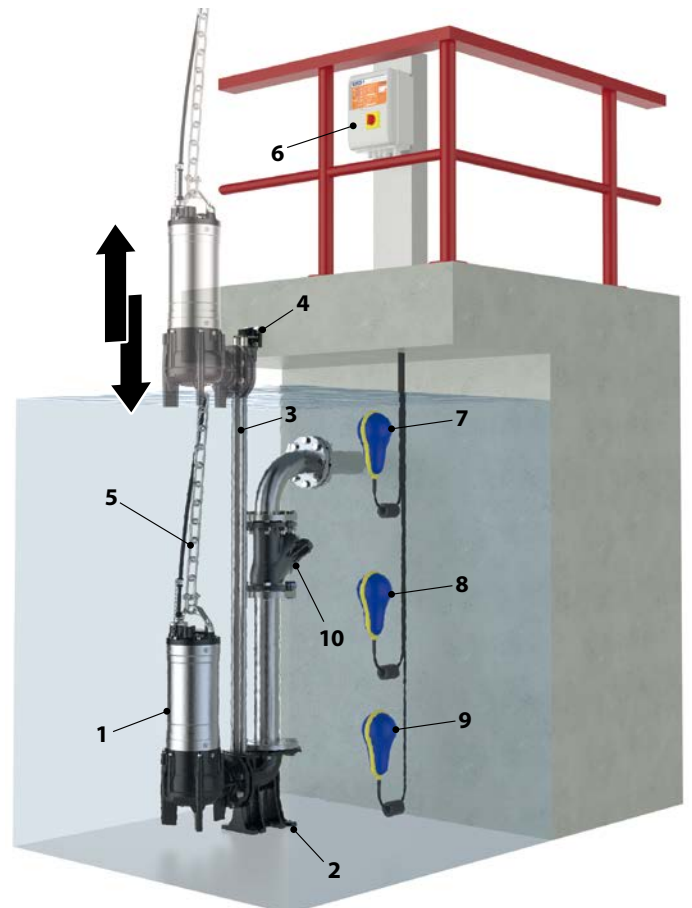

DIMENSIONS (Horizontal delivery version)

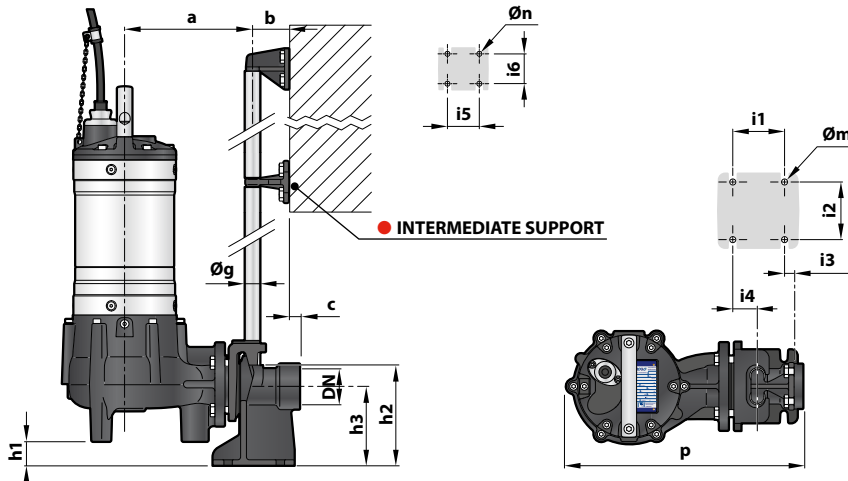

MODEL	Passage of solids mm	PORT DN	DIMENSIONS mm																
			a	b	c	p	h1	h2	h3	i1	i2	i3	i4	i5	i6	Øg	Øm	Øn	
VX /40	Ø 40	2"	214	61	17	400	42	165	130	85	94	16	40	50	48	¾"	12	11	
VX /50	Ø 50						30												

DIMENSIONS (Vertical delivery version)

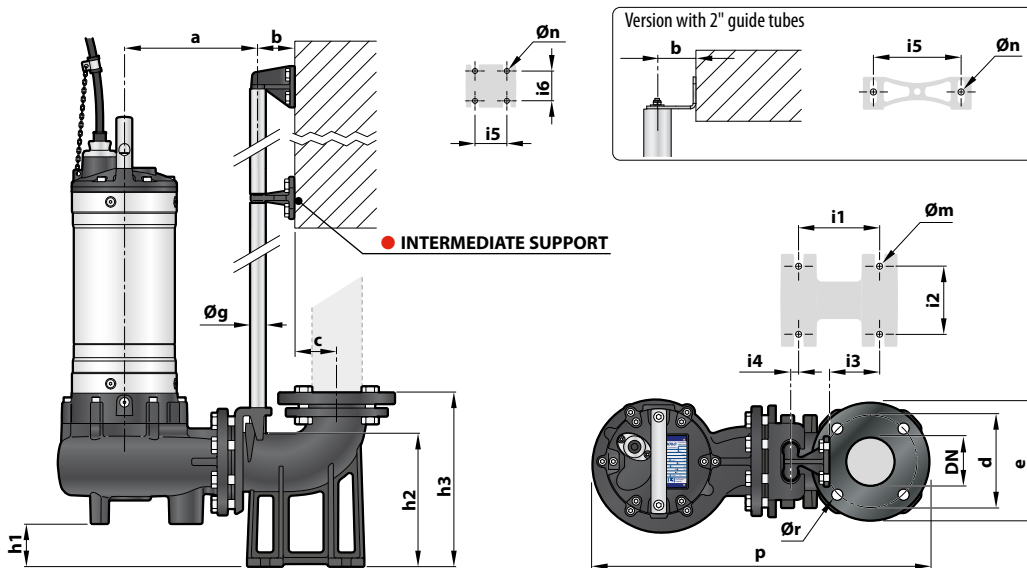

● Version with ¾" guide tubes

MODEL	Passage of solids mm	PORT DN	DIMENSIONS mm																		
			a	b	c	d	e	p	h1	h2	h3	i1	i2	i3	i4	i5	i6	Øg	Øm	Øn	Ør
VX /40	Ø 40	2½"	211	61	52	125	165	506	40	164	216	120	72	62	3	50	48	¾"	14	11	18
VX /50	Ø 50				69	150	190	537	48												
VX /65	Ø 65	3"	213	69	150	190	537	48	216	280	130	112	84	15	50	48	¾"	14	11	18	
BC /35	Ø 35							231													550

● Version with 2" guide tubes

MODEL	Passage of solids mm	PORT DN	DIMENSIONS mm																		
			a	b	c	d	e	p	h1	h2	h3	i1	i2	i3	i4	i5	i6	Øg	Øm	Øn	Ør
VX /50	Ø 50	3"	319	86	95	160	200	706	107	264	392	250	150	34	-	186	-	2"	22	13.5	18
VX /65	Ø 65							697	86												
BC /35	Ø 35							710	107												