

50 Hz

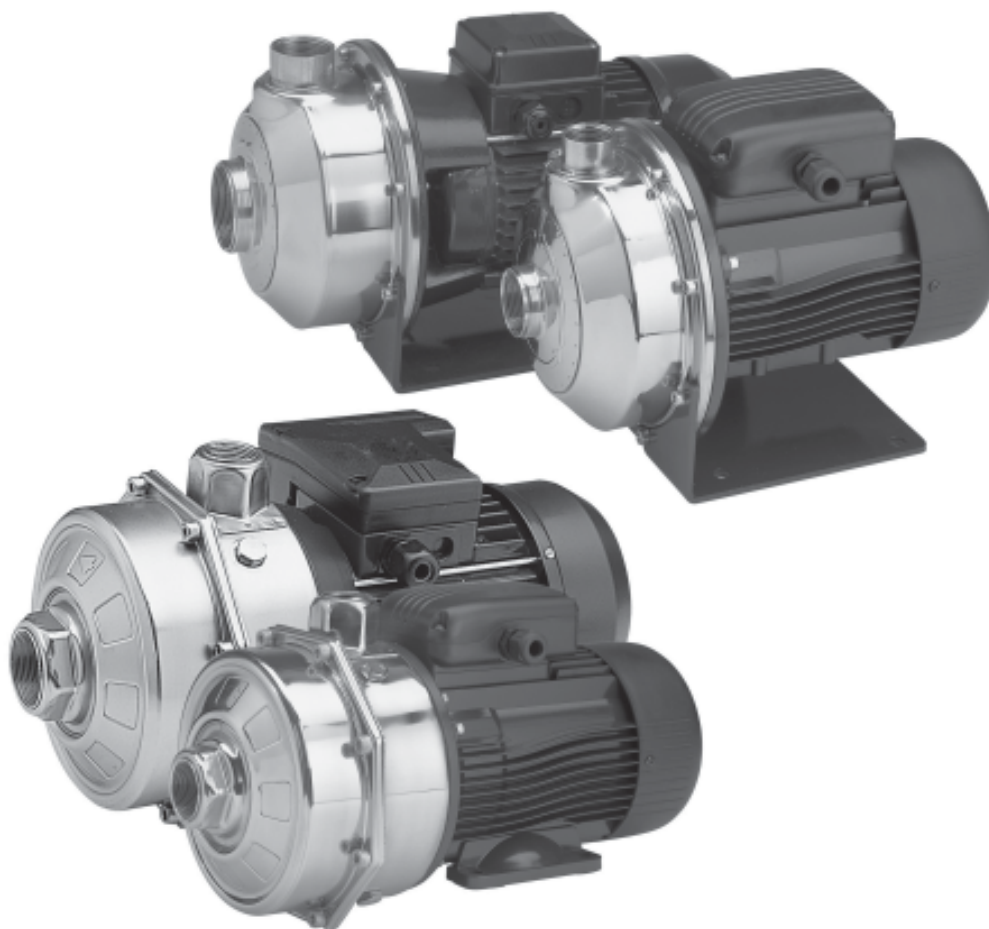

GCEA-GCA Series

GCEA(N)-GCA(N) made of AISI 316

SINGLE AND TWIN-IMPELLER CENTRIFUGAL ELECTRIC PUMPS
EQUIPPED WITH IE2/IE3 MOTORS COMPLYING WITH REGULATION (EC) n. 640/2009

Cod. G91003881 Rev.C Ed.10/2012

 **GOULDS**
WATER TECHNOLOGY
a xylem brand

**GCEA-GCA - GCEA(N)-GCA(N) SERIES
 HYDRAULIC PERFORMANCE RANGE AT 50 Hz**

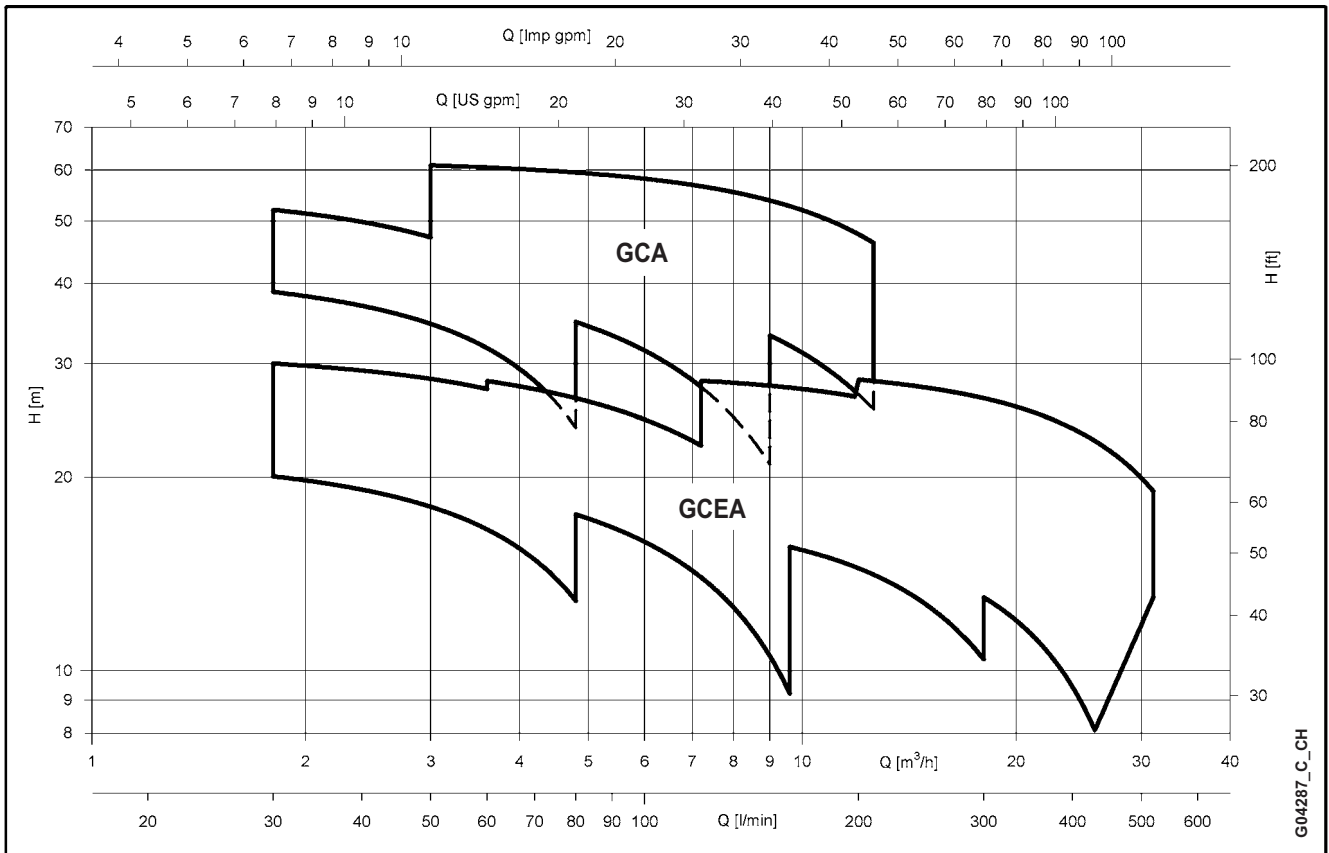

CONTENTS

GCEA-GCEA(N) Series Specifications	5
List of Models and Table of Materials GCEA-GCEA(N) Series	7
Mechanical Seal GCEA-GCEA(N) Series	8
Hydraulic Performance Table and Electrical Data GCEA-GCEA(N) Series	9
Hydraulic Performance Range GCEA-GCEA(N) Series at 50 Hz	12
Dimensions and Weights GCEA-GCEA(N) Series	17
GCA-GCA(N) Series Specifications	19
List of Models and Table of Materials GCA-GCA(N) Series	21
Mechanical Seal GCA-GCA(N) Series	22
Hydraulic Performance Table and Electrical Data GCA-GCA(N) Series	23
Hydraulic Performance Range GCA-GCA(N) Series at 50 Hz	26
Dimensions and Weights GCA-GCA(N) Series	30
Technical Appendix	31

Single-Impeller Centrifugal Electric Pumps

GCEA-GCEA(N) Series

MARKET SECTORS

CIVIL, AGRICULTURAL, INDUSTRIAL.

APPLICATIONS

Version made of AISI 304

- Handling of chemically and mechanically non-aggressive water and liquids (*).
- Water supply.
- Irrigation.
- Water circulation (cold, hot, refrigerated).

* For moderately aggressive liquids, a version with FPM elastomers is available (GCEA../...-V). For aggressive liquids, please contact our sales network.

"N" version made of AISI 316 (for aggressive liquids)

- Reverse osmosis (where demineralized water is used).
- Industrial washing.
- Thermal waters.
- Chlorine dispensing in swimming pools.
- Jewellery industry.
- Wine production.

the overload protection must be provided and installed by the user in the control panel.

- **Three-phase** versions: 220-240/380-415 V 50 Hz, 2 poles, the overload protection must be provided and installed by the user in the control panel.

- Condensate drain plugs in the standard version.

CONSTRUCTION CHARACTERISTICS

- Close-coupled, single-impeller centrifugal pump featuring axial suction and radial discharge.
 - Compact construction, with pump coupled directly to motor; special motor shaft extension in common with the pump and supported by ball bearings.
 - Rotating assembly with back pull-out design, eliminating the need to disconnect the pump body from the pipe line.
 - Threaded suction and discharge ports (Rp ISO 7).
 - High performance enclosed **Impeller** made of **AISI 304** stainless steel (**AISI 316** for N version).
 - **Mechanical seal** with Ceramic/Carbon rings, NBR elastomers, (EPDM for N version) other parts are made of AISI 304 stainless steel (AISI 316 for N version). Mounting dimensions according to EN 12756 (ex DIN 24960) and ISO 3069.
 - **O-rings** made of NBR (EPDM for N version).
 - Mounting pedestal on pump body.
- #### OPTIONAL FEATURES
- Different voltages and frequencies.
 - Different material for the mechanical seal and O-rings.

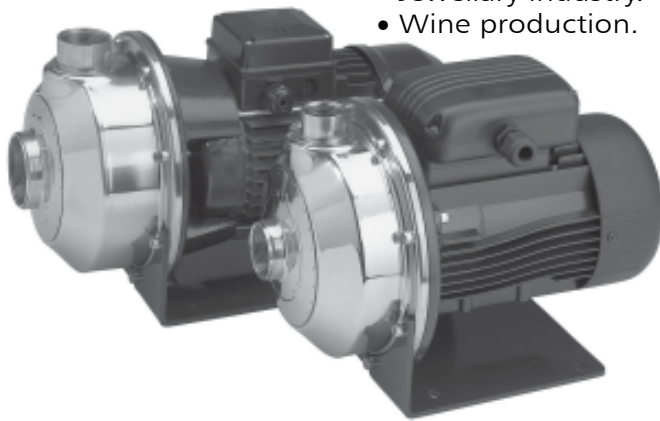

SPECIFICATIONS PUMP

- **Delivery** up to 520 l/min (31 m³/h)
- **Head** up to 32 m.
- **Temperature** of pumped liquid: -10°C to +85°C standard version. -10°C to +110°C (N and V versions).
- Maximum operating **pressure** : 8 bar (PN 8).
- Counter-clockwise rotation facing the pump from the suction port.

MOTOR

- Asynchronous, squirrel cage rotor, close construction, external ventilation.
- **Protection class**: IP55.
- Class 155 (F) **Insulation**.
- Performances to EN 60034-1 specifications.
- **Standard voltage**:
- **Single-phase** versions: 220-240 V 50 Hz, 2 poles, with automatic reset overload protection up to 1,5 kW. For higher powers,

□ **Standard supplied IE2/IE3 motors are compliant with Regulation (EC) no. 640/2009.**

GCEA-GCEA(N) SERIES IDENTIFICATION CODE

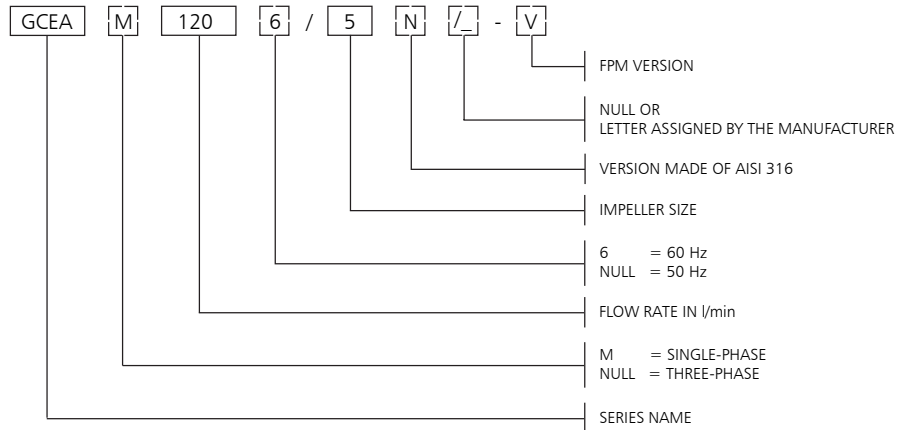

EXAMPLE : GCEAM 120/5-V
GCEA series electric pump, single-phase, flow rate 120 l/min
50 Hz, Impeller size 5, FPM version.

RATING PLATE

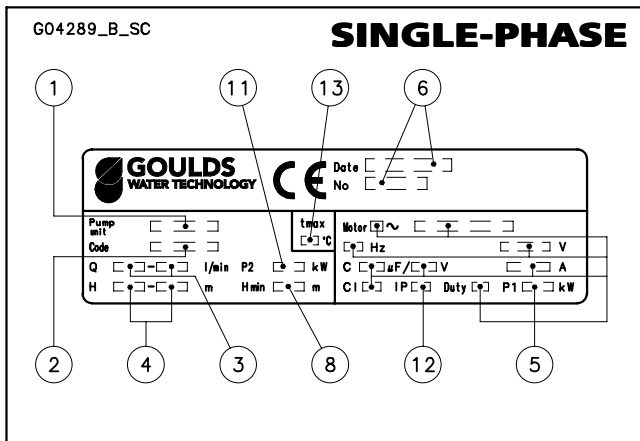

LEGEND

- 1 - Electric pump type
- 2 - Code
- 3 - Delivery range
- 4 - Head range
- 5 - Electrical data
- 6 - Serial number (date + sequential number)
- 8 - Minimum head
- 11 - Rated power
- 12 - Electric pump protection class
- 13 - Maximum temperature of pumped liquid

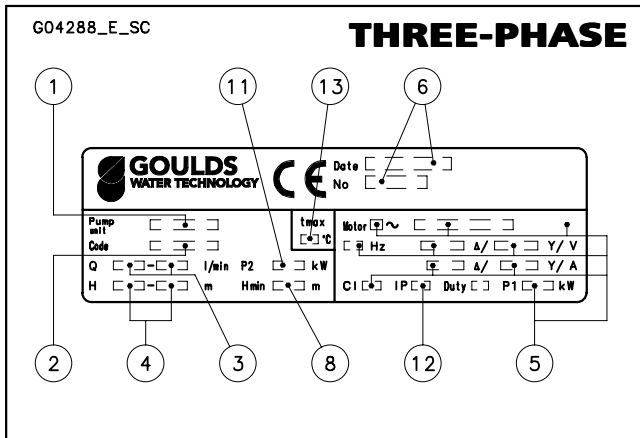

**GCEA - GCEA(N) SERIES
LIST OF MODELS AND TABLE OF MATERIALS**

04304_C_DS

VERSIONS	
GCEA70/3	
GCEA70/5	
GCEA80/5	
GCEA120/3	
GCEA120/5	
GCEA210/2	
GCEA210/3	
GCEA210/4	
GCEA210/5	
GCEA370/1	
GCEA370/2	
GCEA370/3	
GCEA370/5	

gcea-gceaN-en_a_mo

GCEA SERIES TABLE OF MATERIALS

REF. N.	PART	MATERIAL	REFERENCE STANDARDS	
			EUROPE	USA
1	Pump body	Stainless steel	EN 10088-1-X5CrNi18-10 (1.4301)	AISI 304
2	Impeller	Stainless steel	EN 10088-1-X5CrNi18-10 (1.4301)	AISI 304
3	Diffuser	Stainless steel	EN 10088-1-X5CrNi18-10 (1.4301)	AISI 304
4	Seal housing	Stainless steel	EN 10088-1-X5CrNi18-10 (1.4301)	AISI 304
5	Adapter	Aluminium	EN 1706-AC-AISI11Cu2 (Fe) (AC46100)	-
12	Mechanical seal	Ceramic / Carbon / NBR (standard version)		
13	Elastomers	NBR (standard version)		
16	Fill/drain plugs	Stainless steel	EN 10088-1-X5CrNiMo17-12-2 (1.4401)	AISI 316
26	Impeller lock nut	Stainless steel	EN 10088-1-X5CrNiMo17-12-2 (1.4401)	AISI 316
27	Mounting pedestal	Painted steel		
28	Pump body fastening nuts and bolts	Zinc-plated steel		
29	Shaft extension	Stainless steel	EN 10088-1-X5CrNiMo17-12-2 (1.4401)	AISI 316

GCEA(N) SERIES TABLE OF MATERIALS

cea-cea-en_b_tm

REF. N.	PART	MATERIAL	REFERENCE STANDARDS	
			EUROPE	USA
1	Pump body	Stainless steel	EN 10088-1-X2CrNiMo17-12-2 (1.4404)	AISI 316L
2	Impeller	Stainless steel	EN 10088-1-X2CrNiMo17-12-2 (1.4404)	AISI 316L
3	Diffuser	Stainless steel	EN 10088-1-X2CrNiMo17-12-2 (1.4404)	AISI 316L
4	Seal housing	Stainless steel	EN 10088-1-X2CrNiMo17-12-2 (1.4404)	AISI 316L
5	Adapter	Aluminium	EN 1706-AC-AISI11Cu2 (Fe) (AC46100)	-
12	Mechanical seal	Ceramic / Carbon /EPDM		
13	Elastomers	EPDM		
16	Fill/drain plugs	Stainless steel	EN 10088-1-X5CrNiMo17-12-2 (1.4401)	AISI 316
26	Impeller lock nut	Stainless steel	EN 10088-1-X5CrNiMo17-12-2 (1.4401)	AISI 316
27	Mounting pedestal	Painted steel		
28	Pump body fastening nuts and bolts	Zinc-plated		
29	Shaft extension	Stainless steel	EN 10088-1-X5CrNiMo17-12-2 (1.4401)	AISI 316

cea-ceaN-en_a_tm

GCEA-GCEA(N) MECHANICAL SEAL, ACCORDING TO EN 12756

Mechanical seal with mounting dimensions according to EN12756 (ex DIN 24960) and ISO 3069.

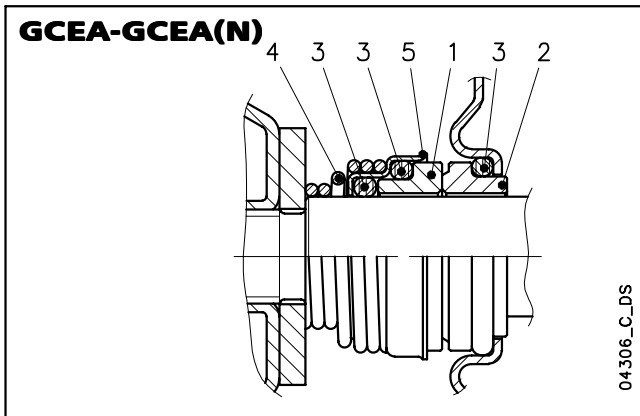

GCEA-GCEA(N) LIST OF MATERIALS

POSITION 1 - 2	POSITION 3	POSITION 4 - 5
B : Resin impregnated carbon	P : NBR	F : AISI 304
C : Special resin impregnated carbon	E : EPDM	G : AISI 316
Q ₁ : Silicon carbide	V : FPM	
U ₃ : Tungsten carbide		
V : Ceramic		

cea-ca_ten-mec-en_b_tm

GCEA MECHANICAL SEALS

TYPE	POSITION					TEMPERATURE (°C)
	1 ROTATING ASSEMBLY	2 FIXED ASSEMBLY	3 ELASTOMERS	4 SPRINGS	5 OTHER COMPONENTS	
STANDARD MECHANICAL SEAL						
VBPGF	V	B	P	G	F	-10 +85
OTHER TYPES OF MECHANICAL SEAL						
VBEGG	V	B	E	G	G	-10 +110
VCEGG	V	C	E	G	G	-10 +110
Q ₁ Q ₁ EGG	Q ₁	Q ₁	E	G	G	-10 +110
U ₃ CEGG	U ₃	C	E	G	G	-10 +110
U ₃ U ₃ EGG	U ₃	U ₃	E	G	G	-10 +110
VBVGG	V	B	V	G	G	-10 +110
VCVGG	V	C	V	G	G	-10 +110
Q ₁ Q ₁ VGG	Q ₁	Q ₁	V	G	G	-10 +110
U ₃ CVGG	U ₃	C	V	G	G	-10 +110
U ₃ U ₃ VGG	U ₃	U ₃	V	G	G	-10 +110

cea_tipi-ten-mec_b_tc

GCEA(N) MECHANICAL SEALS

TYPE	POSITION					TEMPERATURE (°C)
	1 ROTATING ASSEMBLY	2 FIXED ASSEMBLY	3 ELASTOMERS	4 SPRINGS	5 OTHER COMPONENTS	
STANDARD MECHANICAL SEAL						
VBEGG	V	B	E	G	G	-10 +110
OTHER TYPES OF MECHANICAL SEAL						
VCEGG	V	C	E	G	G	-10 +110
Q ₁ Q ₁ EGG	Q ₁	Q ₁	E	G	G	-10 +110
VCVGG	V	C	V	G	G	-10 +110
Q ₁ Q ₁ VGG	Q ₁	Q ₁	V	G	G	-10 +110

cean-can_tipi-ten-mec-en_b_tc

GCEA-GCEA(N) SERIES HYDRAULIC PERFORMANCE TABLE AT 50 Hz, 2 POLES

PUMP TYPE	RATED POWER		Q = DELIVERY																		
			l/min	30	40	60	80	100	120	140	160	180	200	250	300	350	400	430	480	520	
	kW	HP	m ³ /h	0	1,8	2,4	3,6	4,8	6	7,2	8,4	9,6	10,8	12	15	18	21	24	26	29	31
H = TOTAL HEAD METRES COLUMN OF WATER																					
GCEA(M) 70/3	0,37	0,5	22	20,1	19,1	16,6	12,8														
GCEA(M) 70/5	0,55	0,75	31,1	28,8	27,7	24,7	20,2														
GCEA(M) 80/5	0,75	1	32	30	29,3	27,4	24,7	21													
GCEA(M) 120/3	0,55	0,75	22,4			18,9	17,5	15,9	14	11,8	9,2										
GCEA(M) 120/5	0,9	1,2	31,8			28,2	26,5	24,6	22,4	20	17,3										
GCEA(M) 210/2	0,75	1	17,7						16,5	16,1	15,6	15	14,4	12,6	10,4						
GCEA(M) 210/3	1,1	1,5	20,8						19,7	19,3	19	18,5	18	16,5	14,4						
GCEA(M) 210/4	1,5	2	25,5						24,8	24,5	24	23,6	23	21,3	19						
GCEA(M) 210/5	1,85	2,5	29						28,2	27,9	27,5	27,1	26,6	25,1	23,1						
GCEA(M) 370/1	1,1	1,5	16,3									15,5	15,2	14,3	13	11,4	9,4	8,1			
GCEA(M) 370/2	1,5	2	20,4										19,1	18,3	17,2	15,8	14,1	13	10,8		
GCEA(M) 370/3	1,85	2,5	24,4										22,9	22,1	21,1	19,8	18,2	17,1	15	13	
GCEA370/5	3	4	30,3										28,3	27,5	26,5	25,3	23,8	22,8	21	19,0	

gcea-2p50-en_d_th

GCEA-GCEA(N) SERIES ELECTRICAL DATA AT 50 Hz, 2 POLES

PUMP TYPE 1 ~	MOTOR TYPE	INPUT POWER*	INPUT CURRENT*	CAPACIT.	PUMP TYPE 3 ~	MOTOR TYPE	INPUT POWER*	INPUT CURRENT*	INPUT CURRENT*
		kW	220-240 V A	μF / 450 V			kW	220-240 V A	380-415 V A
GCEAM70/3	SM63BG/1045	0,60	2,72	14	GCEA70/3	SM63BG/304	0,61	2,51	1,45
GCEAM70/5	SM71BG/1055	0,97	4,55	16	GCEA70/5	SM71BG/305	0,88	2,86	1,65
GCEAM80/5	SM71BG/1075	1,07	4,87	20	GCEA80/5	SM80BG/307PE	0,98	3,08	1,78
GCEAM120/3	SM71BG/1055	0,91	4,33	16	GCEA120/3	SM71BG/305	0,82	2,74	1,58
GCEAM120/5	SM71BG/1095	1,39	6,24	25	GCEA120/5	SM80BG/311PE	1,28	4,10	2,37
GCEAM210/2	SM71BG/1075	1,13	5,10	20	GCEA210/2	SM80BG/307PE	1,04	3,22	1,86
GCEAM210/3	SM80BG/1115	1,48	6,68	30	GCEA210/3	SM80BG/311PE	1,35	4,24	2,45
GCEAM210/4	SM80BG/1155	1,91	8,60	40	GCEA210/4	SM80BG/315PE	1,73	5,46	3,15
GCEAM210/5	PLM90BG/1225	2,24	10,2	70	GCEA210/5	PLM90BG/322	2,20	7,35	4,24
GCEAM370/1	SM80BG/1115	1,49	6,75	30	GCEA370/1	SM80BG/311PE	1,40	4,35	2,51
GCEAM370/2	SM80BG/1155	2,05	9,26	40	GCEA370/2	SM80BG/315PE	1,95	5,94	3,43
GCEAM370/3	PLM90BG/1225	2,45	11,1	70	GCEA370/3	PLM90BG/322	2,45	7,84	4,53
					GCEA370/5	PLM90BG/330	3,26	10,1	5,86

*Maximum value in specified range.

gcea-2p50-en_f_te

MOTORS FOR GCEA-GCEA(N) SERIES

Standard supplied IE2/IE3 three-phase surface motors $\geq 0,75$ kW are compliant with Regulation (EC) no. 640/2009 and IEC 60034-30.

Electrical performances according to EN 60034-1.

Insulation class 155 (F). IP55 protection. Condensate drain plugs on standard version.

Cooling by fan according to EN 60034-6.

Cable gland metric size according to EN 50262. Standard voltage:

- **Single-phase version:** 220-240 V 50 Hz (incorporated automatic-reset overload protection).
- **Three-phase version:** 220-240/380-415 V 50 Hz (overload protection to be provided by the user).

SINGLE-PHASE MOTORS AT 50 Hz, 2 POLES

P _N kW	MOTOR TYPE	IEC SIZE	Construction Design	INPUT CURRENT I _n (A)		CAPACITOR		DATA FOR 230 V 50 Hz VOLTAGE					
				220-240 V	μF	V	min ⁻¹	I _s / I _n	η %	cosφ	T _n Nm	T _s /T _n	T _m /T _n
0,4	SM63BG/1045	63	SPECIAL	2,79-2,85	14	450	2745	2,64	65,1	0,96	1,39	0,68	1,63
0,55	SM71BG/1055	71		3,76-3,99	16	450	2820	3,72	68,9	0,91	1,86	0,61	2,00
0,75	SM71BG/1075	71		4,90-4,85	20	450	2765	3,42	70,1	0,96	2,59	0,58	1,75
0,95	SM71BG/1095	71		6,25-5,89	25	450	2740	3,39	71,1	0,98	3,31	0,58	1,66
1,1	SM80BG/1115	80		6,88-6,65	30	450	2800	3,89	74,7	0,96	3,75	0,46	1,72
1,5	SM80BG/1155	80		9,21-8,58	40	450	2810	4,00	76,1	0,98	5,09	0,39	1,74
1,85	PLM80BG/1225	90		12,5-11,6	70	450	2825	4,47	82,4	0,97	7,43	0,53	1,87

THREE-PHASE MOTORS AT 50 Hz, 2 POLES

cea-motm-2p50-en_a_te

P _N kW	Efficiency η _N %																		IE	Year of manufacture			
	Δ 220 V Y 380 V			Δ 230 V Y 400 V			Δ 240 V Y 415 V			Δ 380 V Y 660 V			Δ 400 V Y 690 V			Δ 415 V							
	4/4	3/4	2/4	4/4	3/4	2/4	4/4	3/4	2/4	4/4	3/4	2/4	4/4	3/4	2/4	4/4	3/4	2/4					
0,4	-	-	-	-	-	-	-	-	-	-	-	-	-	-	-	-	-	-	-	-	-	By June 2011	
0,55	-	-	-	-	-	-	-	-	-	-	-	-	-	-	-	-	-	-	-	-	-		
0,75	82,5	83,1	81,3	82,8	82,7	80,1	82,6	82,0	78,9	82,5	82,0	78,9	82,5	82,0	78,9	82,5	82,0	78,9	82,5	82,0	78,9		3
0,9	84,0	84,7	83,4	84,4	84,5	82,5	84,3	84,0	81,4	84,0	84,0	81,4	84,0	84,0	81,4	84,0	84,0	81,4	84,0	84,0	81,4		3
1,1	84,0	84,7	83,4	84,4	84,5	82,5	84,3	84,0	81,4	84,0	84,0	81,4	84,0	84,0	81,4	84,0	84,0	81,4	84,0	84,0	81,4		3
1,5	85,6	86,5	85,8	85,9	86,4	84,9	86,0	86,0	84,0	85,6	86,0	84,0	85,6	86,0	84,0	85,6	86,0	84,0	85,6	86,0	84,0		3
1,85	83,7	83,7	83,7	83,7	83,7	83,7	83,7	83,7	83,7	83,7	83,7	83,7	83,7	83,7	83,7	83,7	83,7	83,7	83,7	83,7	83,7		2
2,2	83,7	83,7	83,7	83,7	83,7	83,7	83,7	83,7	83,7	83,7	83,7	83,7	83,7	83,7	83,7	83,7	83,7	83,7	83,7	83,7	83,7		2
3	85,5	86,8	85,6	86,1	86,8	85,6	86,3	86,8	85,6	85,5	86,8	85,6	85,5	86,8	85,6	85,5	86,8	85,6	85,5	86,8	85,6	2	

P _N kW	Manufacturer		IEC SIZE	Construction Design	N. of Poles	f _n Hz	Data for 400 V / 50 Hz Voltage				
	XYLEM WATER SYSTEMS USA LLC 1 Goulds Drive - Auburn NY 13021 - U.S.A.						cosφ	I _s / I _N	T _N Nm	T _s /T _N	T _m /T _N
	Model										
0,4	SM63BG/304		63	SPECIAL	2	50	0,66	4,32	1,38	4,14	3,13
0,55	SM71BG/305		71				0,74	5,97	1,85	3,74	3,56
0,75	SM80BG/307PE		80				0,78	7,38	2,48	3,57	3,75
0,9	SM80BG/311PE		80				0,79	8,31	3,63	3,95	3,95
1,1	SM80BG/311PE		80				0,79	8,31	3,63	3,95	3,95
1,5	SM80BG/315PE		80				0,80	8,80	4,96	4,31	4,10
1,85	PLM90BG/322		90				0,80	8,63	7,25	3,74	3,71
2,2	PLM90BG/322		90				0,80	8,63	7,25	3,74	3,71
3	PLM90BG/330		90	0,82	8,39	9,96	3,50	3,32			

P _N kW	Voltage U _N V											n _N min ⁻¹	Operating conditions **			
	Δ			Y			Δ			Y			Altitude Above Sea Level (m)	T. amb min/max °C	ATEX	
	220 V	230 V	240 V	380 V	400 V	415 V	380 V	400 V	415 V	660 V	690 V					
0,4	2,20	2,34	2,51	1,27	1,35	1,45	-	-	-	-	-	2740 ÷ 2790	See note:	≤ 1000	-15 / 40	No
0,55	2,56	2,56	2,62	1,48	1,48	1,51	-	-	-	-	-	2825 ÷ 2850				
0,75	2,96	2,94	2,96	1,71	1,70	1,71	1,70	1,69	1,70	0,98	0,98	2875 ÷ 2895				
0,9	4,19	4,14	4,16	2,42	2,39	2,40	2,41	2,38	2,38	1,39	1,37	2870 ÷ 2900				
1,1	4,19	4,14	4,16	2,42	2,39	2,40	2,41	2,38	2,38	1,39	1,37	2870 ÷ 2900				
1,5	5,56	5,49	5,51	3,21	3,17	3,18	3,21	3,18	3,19	1,85	1,84	2870 ÷ 2895				
1,85	8,05	8,04	8,09	4,65	4,64	4,67	4,62	4,61	4,63	2,67	2,66	2885 ÷ 2900				
2,2	8,05	8,04	8,09	4,65	4,64	4,67	4,62	4,61	4,63	2,67	2,66	2885 ÷ 2900				
3	10,8	10,6	10,6	6,23	6,14	6,12	6,18	6,10	6,06	3,57	3,52	2850 ÷ 2885				

Note: Observe the regulations and codes locally in force regarding sorted waste disposal.

gcea-ie2-mott-2p50-en_b_te

** Operating conditions to be referred to motor only. About electric pump, refer to limits in user's manual.

AVAILABLE VOLTAGES MOTORS FOR GCEA-GCEA(N) SERIES

P _N kW	IEC SIZE	SINGLE-PHASE							
		50 Hz				60 Hz			
		1 x 220-240				1 x 110-120			
		1 x 100				1 x 220-230			
		1 x 110-120				1 x 100			
		1 x 220-230				1 x 110-115			
		1 x 100				1 x 120-127			
		1 x 200-210							
0,4	63	s	o	o	s	-	o	-	-
0,55	71	s	o	o	s	o	o	o	o
0,75	71	s	o	o	s	o	o	o	o
0,95	71	s	o	o	s	o	o	o	o
1,1	80	s	-	o	s	-	o	-	o
1,5	80	s	-	-	s	-	o	-	o
2,2	90	s	-	-	s	-	-	-	-

s = Standard voltage o = Optional voltage

P _N kW	THREE-PHASE - 2 POLES														
	50 Hz					60 Hz					50/60 Hz				
	3 x 220-230-240/380-400-415					3 x 255-265-277/440-460-480					3 x 230/400 50 Hz				
	3 x 380-400-415/660-690					3 x 380-400/660-690					3 x 265/460 60 Hz				
	3 x 200-208/346-360					3 x 440-460-480/-					3 x 400/690 50 Hz				
	3 x 255-265/440-460					3 x 110-115/190-200					3 x 460/- 60 Hz				
	3 x 290-300/500-525					3 x 200-208/346-360					3 x 400/690 50 Hz				
	3 x 440-460/-					3 x 330-346/575-600					3 x 460/- 60 Hz				
	3 x 500-525/-					3 x 575/-									
	3 x 220-230/380-400														
	3 x 255-265-277/440-460-480														
	3 x 380-400/660-690														
	3 x 440-460-480/-														
	3 x 110-115/190-200														
	3 x 200-208/346-360														
	3 x 330-346/575-600														
	3 x 575/-														
0,4	s	o	o	o	o	s	o	o	o	o	o	o	o	o	o
0,55	s	o	o	o	o	s	o	o	o	o	o	o	o	o	o
0,75	s	o	o	o	o	s	o	o	o	o	o	o	o	o	o
0,95	s	o	o	o	o	s	o	o	o	o	o	o	o	o	o
1,1	s	o	o	o	o	s	o	o	o	o	o	o	o	o	o
1,5	s	o	o	o	o	s	o	o	o	o	o	o	o	o	o
2,2	s	o	o	o	o	s	o	o	o	o	o	o	o	o	o
3	s	o	o	o	o	s	o	o	o	o	o	o	o	o	o

- = Not available

cea-volt-low-a-en_a_te

**GCEA-GCEA(N) SERIES
 HYDRAULIC PERFORMANCE RANGE AT 50 Hz, 2 POLES**

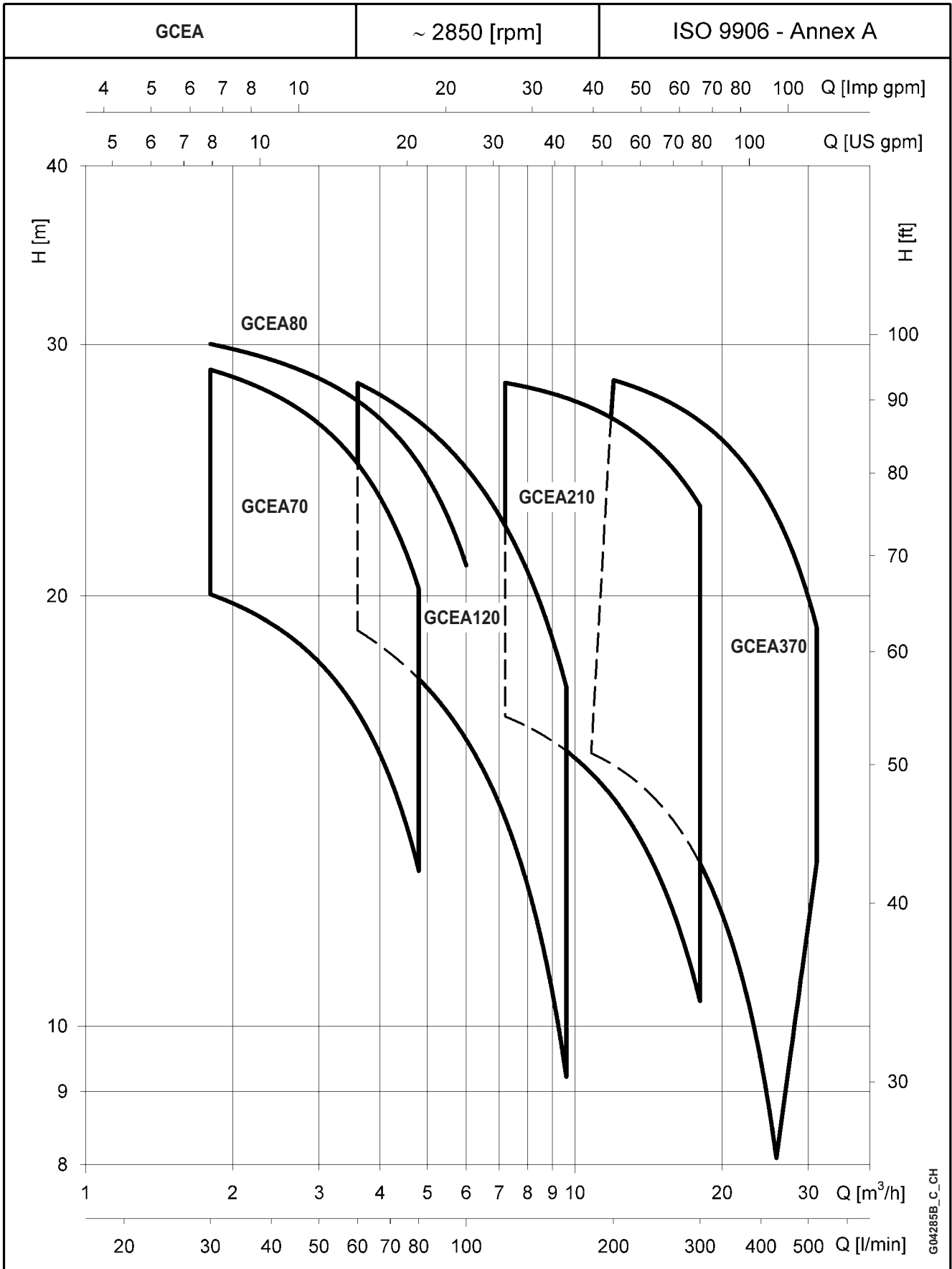

G04285B_C_CH

**GCEA70-GCEA80 SERIES
OPERATING CHARACTERISTICS AT 50 Hz, 2 POLES**

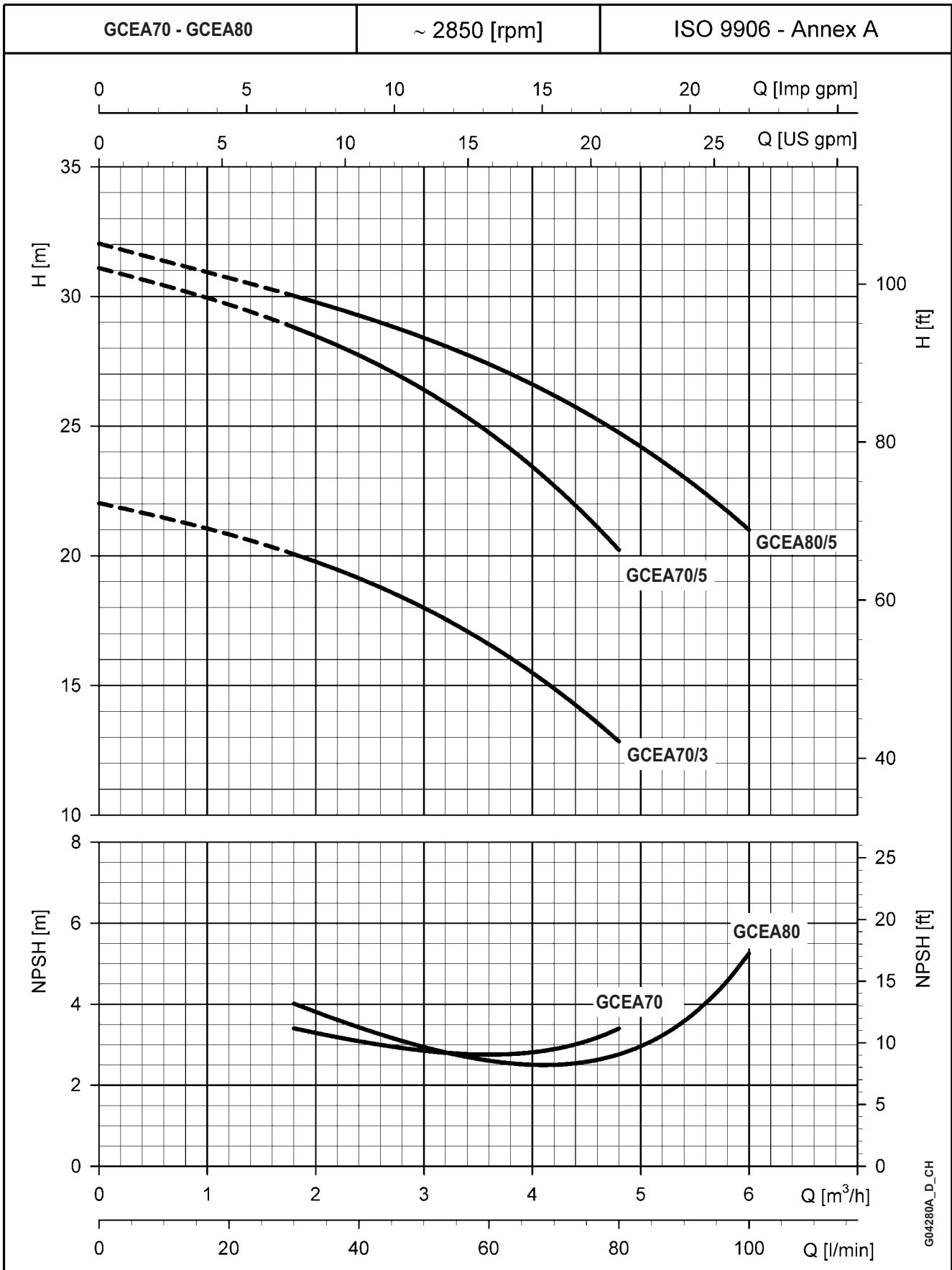

These performances are valid for liquids with density $\rho = 1.0 \text{ Kg/dm}^3$ and kinematic viscosity $\nu = 1 \text{ mm}^2/\text{sec}$.

**GCEA120 SERIES
 OPERATING CHARACTERISTICS AT 50 Hz, 2 POLES**

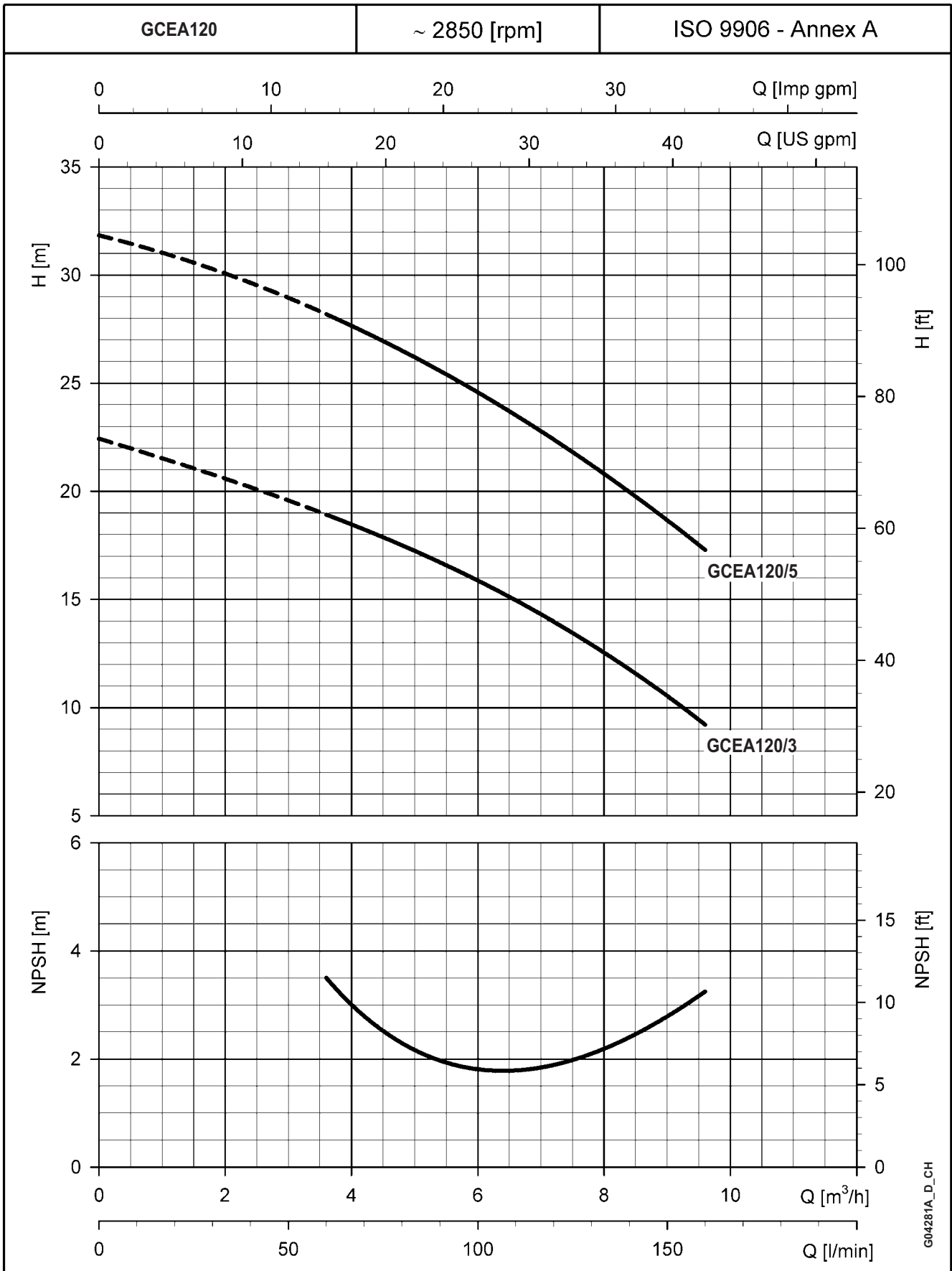

These performances are valid for liquids with density $\rho = 1.0 \text{ Kg/dm}^3$ and kinematic viscosity $\nu = 1 \text{ mm}^2/\text{sec}$.

**GCEA210 SERIES
 OPERATING CHARACTERISTICS AT 50 Hz, 2 POLES**

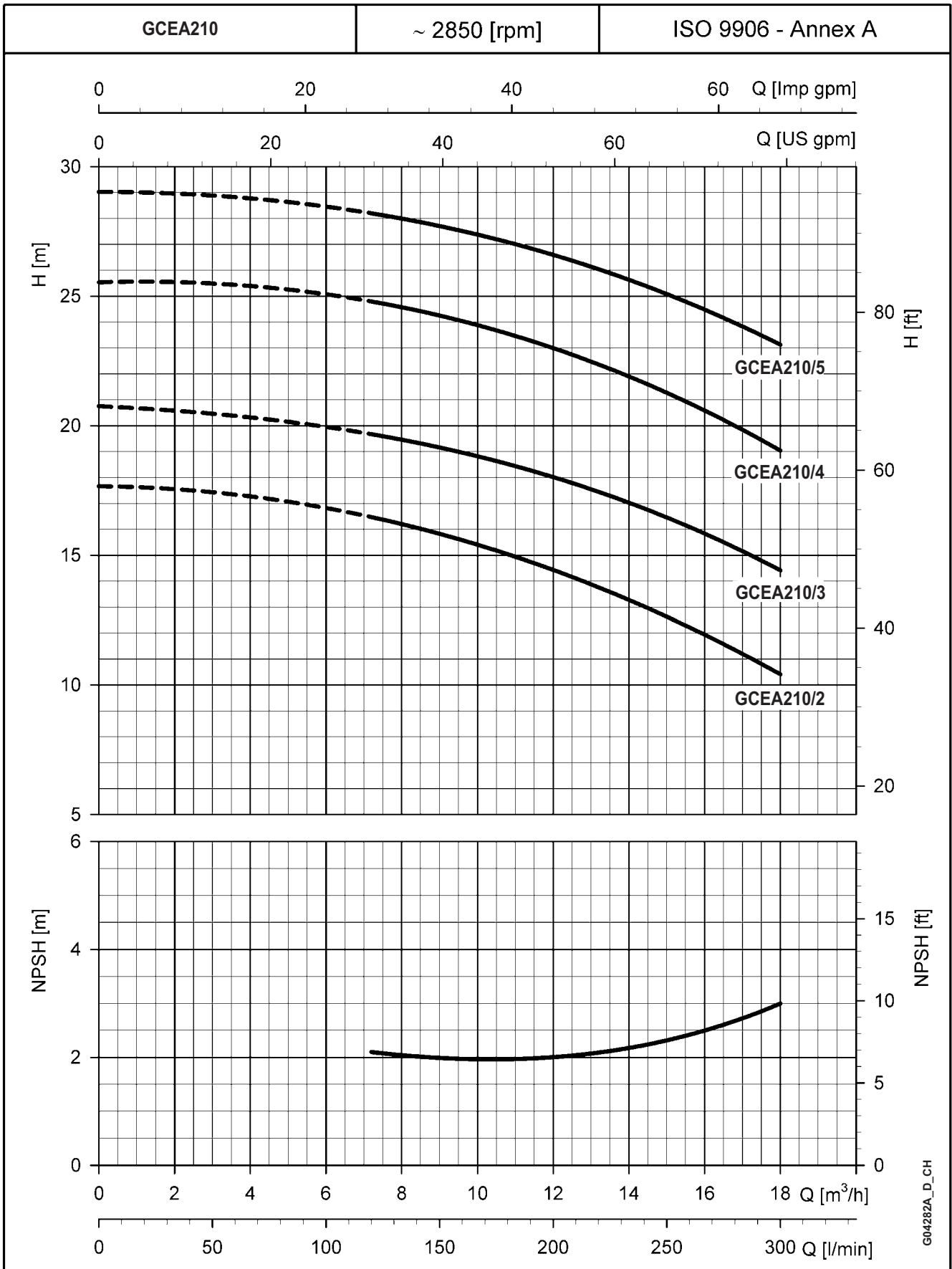

These performances are valid for liquids with density $\rho = 1.0 \text{ Kg/dm}^3$ and kinematic viscosity $\nu = 1 \text{ mm}^2/\text{sec}$.

**GCEA370 SERIES
OPERATING CHARACTERISTICS AT 50 Hz, 2 POLES**

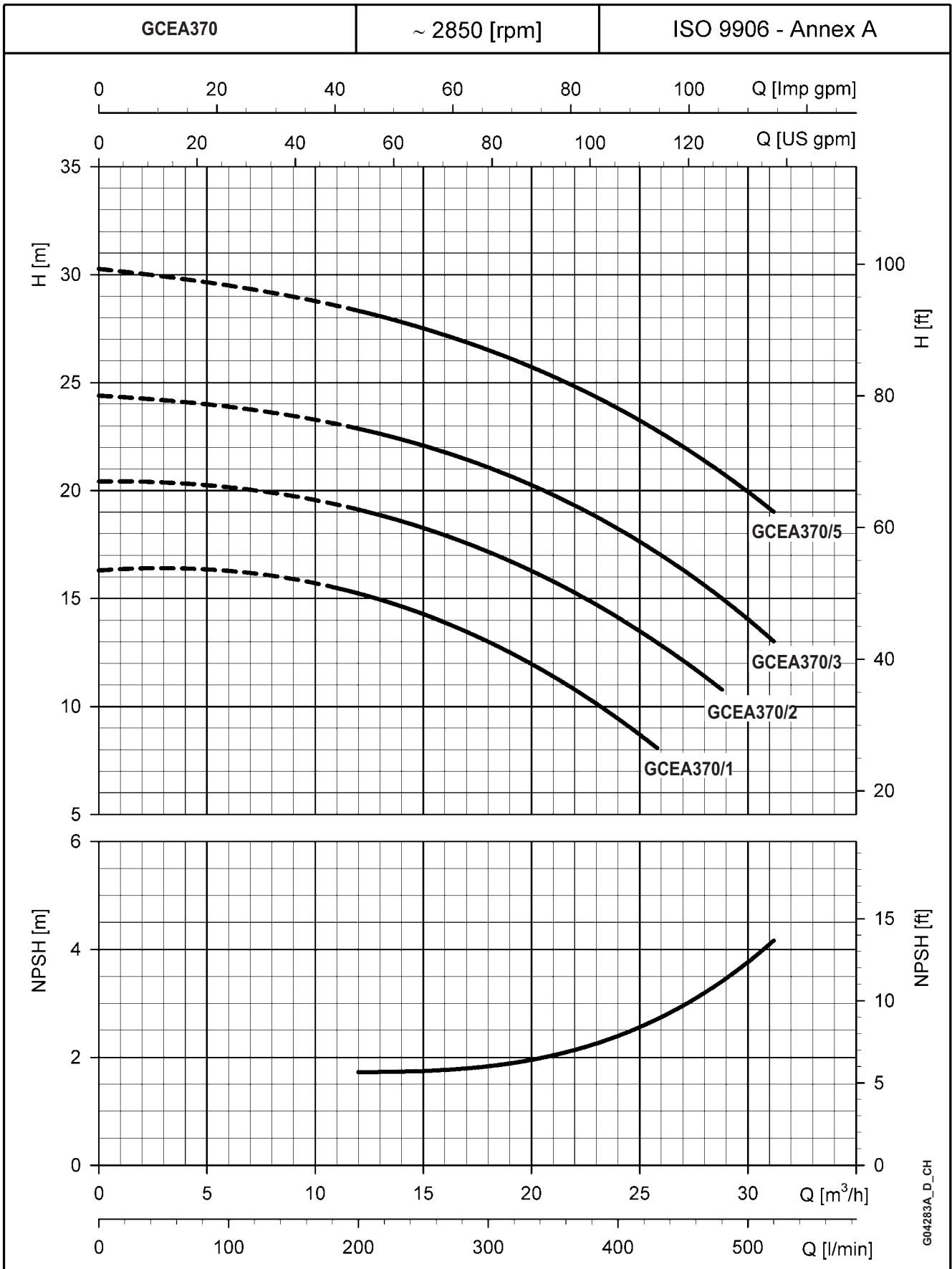

These performances are valid for liquids with density $\rho = 1.0 \text{ Kg/dm}^3$ and kinematic viscosity $\nu = 1 \text{ mm}^2/\text{sec}$.

**GCEA-GCEA(N) SERIES
DIMENSIONS AND WEIGHTS AT 50 Hz, 2 POLES**

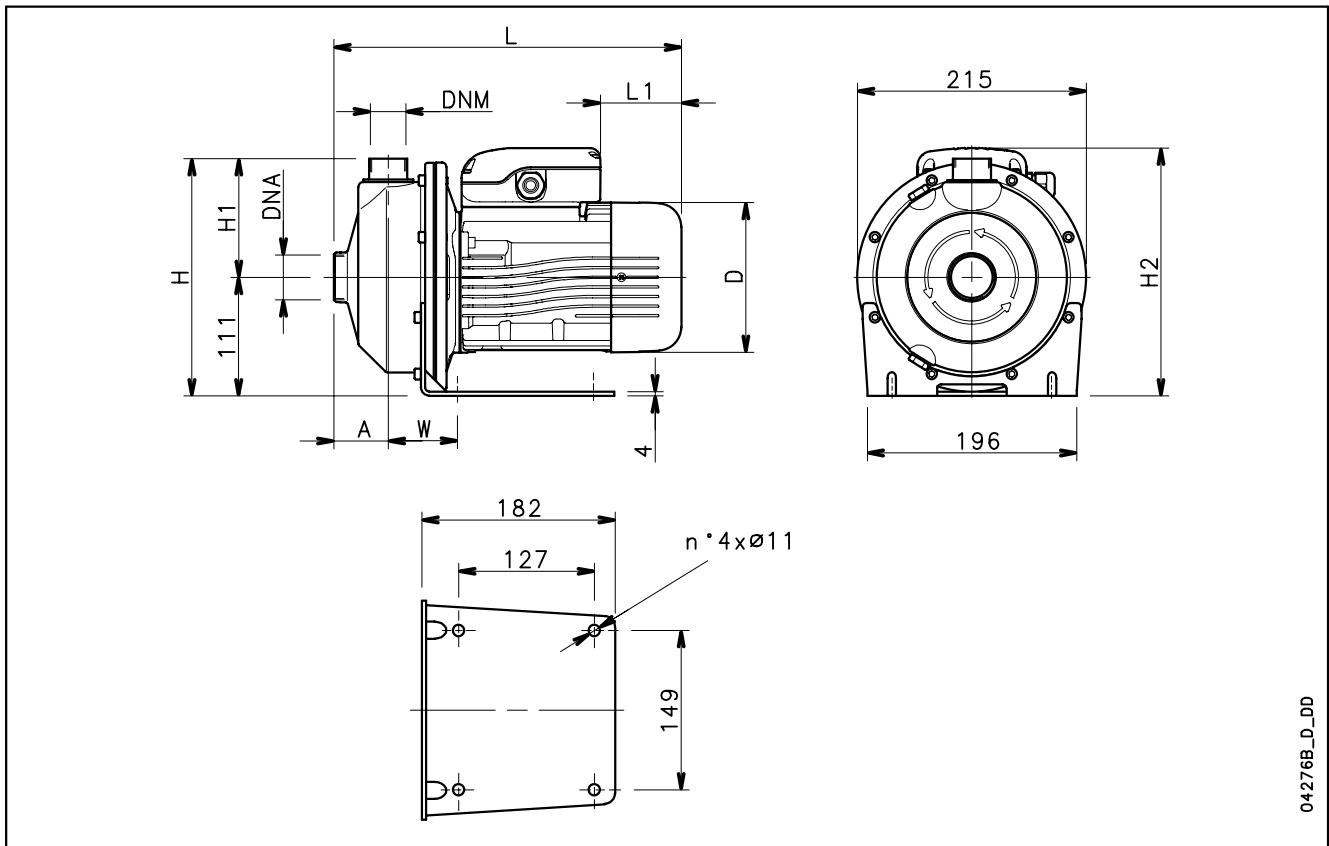

04276B_D_DD

PUMP TYPE	DIMENSIONS (mm)								DNA	DNM	WEIGHT kg
	A	D	H	H1	H2	L	L1	W			
GCEAM 70/3/A	51	120	222	111	222	311	62	65	Rp 1¼	Rp 1	9,7
GCEAM 70/5/A	51	140	222	111	232	325	76	65	Rp 1¼	Rp 1	11,6
GCEAM 80/5/A	51	140	222	111	232	325	76	65	Rp 1¼	Rp 1	12,5
GCEAM 120/3/A	51	140	222	111	232	325	76	65	Rp 1¼	Rp 1	11,5
GCEAM 120/5/A	51	140	222	111	241	325	31	65	Rp 1¼	Rp 1	13
GCEAM 210/2/A	54	140	224	113	232	339	76	76	Rp 1½	Rp 1¼	13
GCEAM 210/3/A	54	156	224	113	248	385	69	76	Rp 1½	Rp 1¼	14,5
GCEAM 210/4/A	54	156	224	113	248	385	69	76	Rp 1½	Rp 1¼	16,1
GCEAM 210/5/P	54	174	224	113	262	429	84	76	Rp 1½	Rp 1¼	17
GCEAM 370/1/A	54	156	224	113	248	385	69	76	Rp 2	Rp 1¼	14
GCEAM 370/2/A	54	156	224	113	248	385	69	76	Rp 2	Rp 1¼	16,1
GCEAM 370/3/P	54	174	224	113	262	429	84	76	Rp 2	Rp 1¼	20
GCEA 70/3/A	51	120	222	111	222	311	62	65	Rp 1¼	Rp 1	9,7
GCEA 70/5/A	51	140	222	111	232	325	76	65	Rp 1¼	Rp 1	11,6
GCEA 80/5/D	51	155	222	111	240	371	114	65	Rp 1¼	Rp 1	14,4
GCEA 120/3/A	51	140	222	111	232	325	76	65	Rp 1¼	Rp 1	11,5
GCEA 120/5/D	51	155	222	111	240	371	114	65	Rp 1¼	Rp 1	14,6
GCEA 210/2/D	54	155	224	113	240	385	114	76	Rp 1½	Rp 1¼	14,6
GCEA 210/3/D	54	155	224	113	240	385	114	76	Rp 1½	Rp 1¼	16,4
GCEA 210/4/D	54	155	224	113	240	385	114	76	Rp 1½	Rp 1¼	17,9
GCEA 210/5/C	54	174	224	113	245	429	172	76	Rp 1½	Rp 1¼	21
GCEA 370/1/D	54	155	224	113	240	385	114	76	Rp 2	Rp 1¼	15,8
GCEA 370/2/D	54	155	224	113	240	385	114	76	Rp 2	Rp 1¼	17,9
GCEA 370/3/C	54	174	224	113	245	429	172	76	Rp 2	Rp 1¼	21
GCEA 370/5/P	54	174	224	113	245	429	172	76	Rp 2	Rp 1¼	21

Twin-Impeller Centrifugal Electric Pumps

GCA-GCA(N) Series

MARKET SECTORS

CIVIL, AGRICULTURAL, INDUSTRIAL.

APPLICATIONS

Version made of AISI 304

- Handling of chemically and mechanically non-aggressive water and liquids (*).
- Water supply.
- Irrigation.
- Water circulation (cold, hot, refrigerated).

* For moderately aggressive liquids, a version with FPM elastomers is available (GCA../..-V). For aggressive liquids, please contact our sales network.

"N" version made of AISI 316 (for aggressive liquids)

- Reverse osmosis (where demineralized water is used).
- Industrial washing.
- Thermal waters.
- Chlorine dispensing in swimming pools.
- Jewellery industry.
- Wine production.

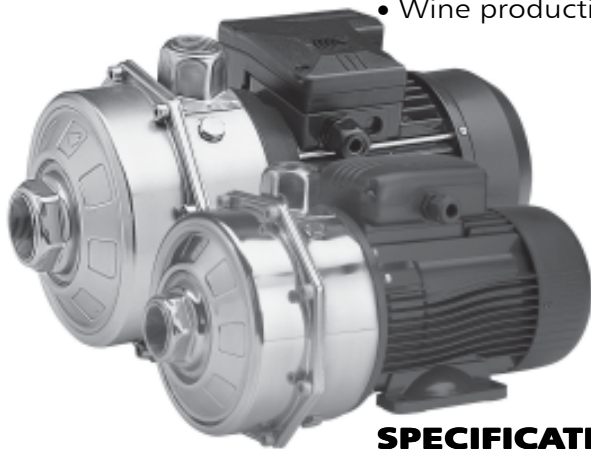

SPECIFICATIONS PUMP

- **Delivery** up to 210 l/min (12,5 m³/h).
- **Head** fino a 62 m.
- **Temperature** of pumped liquid: -10°C to +85°C standard version. -10°C to +110°C (N and V versions).
- Maximum operating **pressure** : 8 bar (PN 8).
- Counter-clockwise rotation facing the pump from the suction port.

MOTOR

- Asynchronous, squirrel cage rotor, close construction, external ventilation.
- **Protection class:** IP55.
- Class 155 (F) **Insulation.**
- Performances to EN 60034-1 specifications.
- **Standard voltage:**
 - **Single-phase** versions: 220-240 V 50 Hz, 2 poles, with automatic reset overload protection up to 1,5 kW. For higher powers,

the overload protection must be provided and installed by the user in the control panel.

- **Three-phase** versions: 220-240/380-415 V 50 Hz, 2 poles, the overload protection must be provided and installed by the user in the control panel.

- Condensate drain plugs in the standard version.

CONSTRUCTION CHARACTERISTICS

- Close-coupled, single-impeller centrifugal pump featuring axial suction and radial discharge.
- Compact construction, with pump coupled directly to motor; special motor shaft extension in common with the pump and supported by ball bearings.
- Threaded suction and discharge ports (Rp ISO 7).
- High performance enclosed **Impeller** made of **AISI 304** stainless steel (**AISI 316** for N version).
- **Mechanical seal** with Ceramic/Carbon rings, NBR elastomers, (EPDM for N version) other parts are made of AISI 304 stainless steel (AISI 316 for N version). Mounting dimensions according to EN 12756 (ex DIN 24960) and ISO 3069.
- **O-rings** made of NBR (EPDM for N version).
- Mounting pedestal on motor.

OPTIONAL FEATURES

- Different voltages and frequencies.
- Different material for the mechanical seal and O-rings.

□ **Standard supplied IE2/IE3 motors are compliant with Regulation (EC) no. 640/2009.**

GCA-GCA(N) SERIES IDENTIFICATION CODE

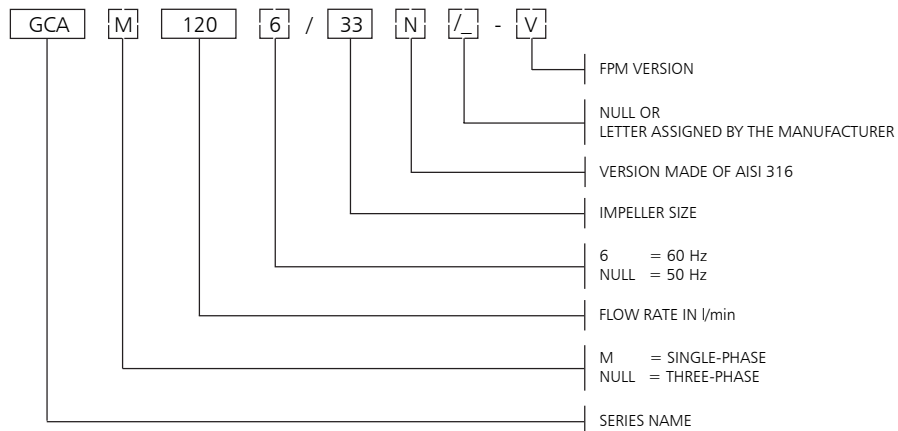

EXAMPLE : GCAM 120/33-V
 GCA series electric pump, single-phase, flow rate 120 l/min
 50 Hz, Impeller size 33, FPM version.

RATING PLATE

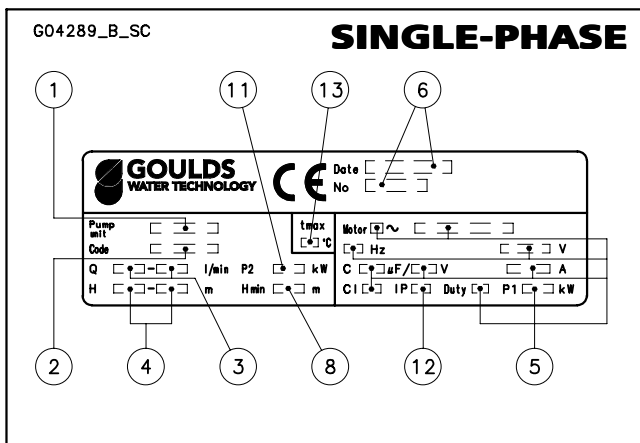

LEGEND

- 1 - Electric pump type
- 2 - Code
- 3 - Delivery range
- 4 - Head range
- 5 - Electrical data
- 6 - Serial number (date + sequential number)
- 8 - Minimum head
- 11 - Rated power
- 12 - Electric pump protection class
- 13 - Maximum temperature of pumped liquid

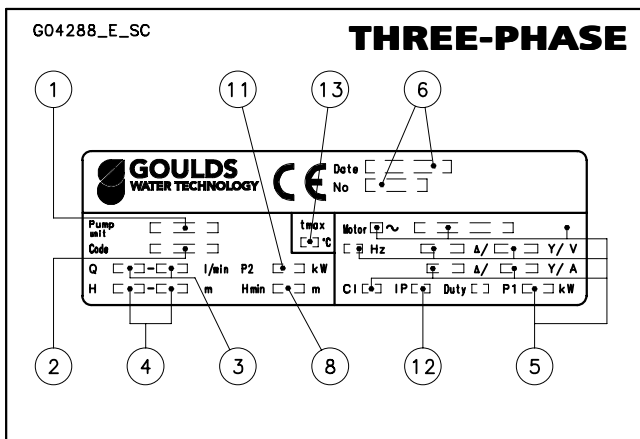

GCA - GCA(N) SERIES LIST OF MODELS AND TABLE OF MATERIALS

02179_B_DS

VERSIONS	
GCA70/33	
GCA70/34	
GCA70/45	
GCA120/33	
GCA120/35	
GCA120/55	
GCA200/33	
GCA200/35	
GCA200/55	

gca-gcaN-en_a_mo

GCA SERIES TABLE OF MATERIALS

REF. N.	PART	MATERIAL	REFERENCE STANDARDS	
			EUROPE	USA
1	Suction flange	Stainless steel	EN 10088-1-X5CrNi18-10 (1.4301)	AISI 304
2	Pump body	Stainless steel	EN 10088-1-X5CrNi18-10 (1.4301)	AISI 304
3	Impeller	Stainless steel	EN 10088-1-X5CrNi18-10 (1.4301)	AISI 304
4	Diffuser cover	Stainless steel	EN 10088-1-X5CrNi18-10 (1.4301)	AISI 304
5	Diffuser cover	Stainless steel	EN 10088-1-X5CrNi18-10 (1.4301)	AISI 304
8	Impeller spacer	Stainless steel	EN 10088-1-X5CrNi18-10 (1.4301)	AISI 304
9	Elastomers	NBR (standard version)		
11	Mechanical seal	Ceramic / Carbon / NBR (standard version)		
13	Fill/drain plugs	Stainless steel	EN 10088-1-X5CrNiMo17-12-2 (1.4401)	AISI 316
24	Mounting pedestal	Aluminium	EN 1706-AC-AISI11Cu2 (Fe) (AC46100)	-
33	Adapter	Aluminium	EN 1706-AC-AISI11Cu2 (Fe) (AC46100)	-
34	Pump body fastening nuts and bolts	Zinc-plated steel		
35	Impeller shoulder washer	Stainless steel	EN 10088-1-X5CrNi18-10 (1.4301)	AISI 304
36	Key	Stainless steel	EN 10088-1-X5CrNiMo17-12-2 (1.4401)	AISI 316
37	Impeller lock nut and washer	Stainless steel	EN 10088-1-X5CrNi18-10 (1.4301)	AISI 304
38	Shaft extension	Stainless steel	EN 10088-1-X5CrNiMo17-12-2 (1.4401)	AISI 316

GCA(N) SERIES TABLE OF MATERIALS

ca-ca-en_b_tm

REF. N.	PART	MATERIAL	REFERENCE STANDARDS	
			EUROPE	USA
1	Suction flange	Stainless steel	EN 10088-1-X2CrNiMo17-12-2 (1.4404)	AISI 316L
2	Pump body	Stainless steel	EN 10088-1-X2CrNiMo17-12-2 (1.4404)	AISI 316L
3	Impeller	Stainless steel	EN 10088-1-X2CrNiMo17-12-2 (1.4404)	AISI 316L
4	Diffuser cover	Stainless steel	EN 10088-1-X2CrNiMo17-12-2 (1.4404)	AISI 316L
5	Diffuser	Stainless steel	EN 10088-1-X2CrNiMo17-12-2 (1.4404)	AISI 316L
8	Impeller spacer	Stainless steel	EN 10088-1-X5CrNiMo17-12-2 (1.4401)	AISI 316
9	Elastomers	EPDM (standard version)		
11	Mechanical seal	Ceramic / Carbon / EPDM (standard version)		
13	Fill/drain plugs	Stainless steel	EN 10088-1-X5CrNiMo17-12-2 (1.4401)	AISI 316
24	Mounting pedestal	Aluminium	EN 1706-AC-AISI11Cu2 (Fe) (AC46100)	-
33	Adapter	Aluminium	EN 1706-AC-AISI11Cu2 (Fe) (AC46100)	-
34	Pump body fastening nuts and bolts	Zinc-plated steel		
35	Impeller shoulder washer	Stainless steel	EN 10088-1-X2CrNiMo17-12-2 (1.4404)	AISI 316L
36	Key	Stainless steel	EN 10088-1-X5CrNiMo17-12-2 (1.4401)	AISI 316
37	Impeller lock nut and washer	Stainless steel	EN 10088-1-X5CrNiMo17-12-2 (1.4401)	AISI 316
38	Shaft extension	Stainless steel	EN 10088-1-X5CrNiMo17-12-2 (1.4401)	AISI 316

ca-caN-en_a_tm

GCA-GCA(N) MECHANICAL SEAL, ACCORDING TO EN 12756

Mechanical seal with mounting dimensions according to EN12756 (ex DIN 24960) and ISO 3069.

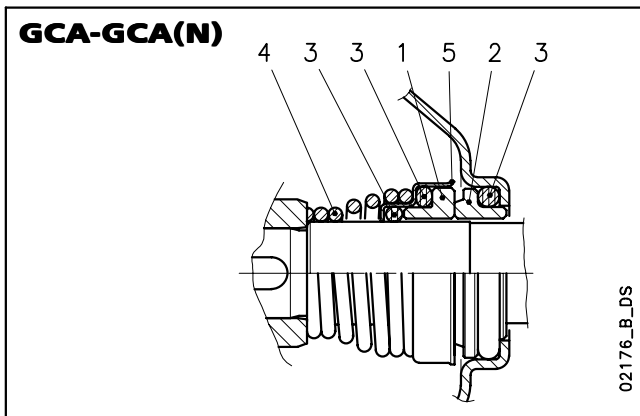

GCA-GCA(N) LIST OF MATERIALS

POSITION 1 - 2	POSITION 3	POSITION 4 - 5
B : Resin impregnated carbon	P : NBR	F : AISI 304
C : Special resin impregnated carbon	E : EPDM	G : AISI 316
Q₁ : Silicon carbide	V : FPM	
U₃ : Tungsten carbide		
V : Ceramic		

cea-ca_ten-mec-en_b_tm

GCA MECHANICAL SEALS

TYPE	POSITION					TEMPERATURE (°C)
	1 ROTATING ASSEMBLY	2 FIXED ASSEMBLY	3 ELASTOMERS	4 SPRINGS	5 OTHER COMPONENTS	
STANDARD MECHANICAL SEAL						
VBPGF	V	B	P	G	F	-10 +85
OTHER TYPES OF MECHANICAL SEAL						
VBEGF	V	B	E	G	F	-10 +110
VCEGG	V	C	E	G	G	-10 +110
Q ₁ Q ₁ EGF	Q ₁	Q ₁	E	G	F	-10 +110
U ₃ BEGF	U ₃	B	E	G	F	-10 +110
U ₃ CEGF	U ₃	C	E	G	F	-10 +110
U ₃ U ₃ EGF	U ₃	U ₃	E	G	F	-10 +110
VBVGF	V	B	V	G	F	-10 +110
VCVGF	V	C	V	G	F	-10 +110
Q ₁ Q ₁ VGF	Q ₁	Q ₁	V	G	F	-10 +110
U ₃ CVGF	U ₃	C	V	G	F	-10 +110
U ₃ U ₃ VGF	U ₃	U ₃	V	G	F	-10 +110

ca_tipi-ten-mec-en_b_tc

GCA(N) MECHANICAL SEALS

TYPE	POSITION					TEMPERATURE (°C)
	1 ROTATING ASSEMBLY	2 FIXED ASSEMBLY	3 ELASTOMERS	4 SPRINGS	5 OTHER COMPONENTS	
STANDARD MECHANICAL SEAL						
VBEGG	V	B	E	G	G	-10 +110
OTHER TYPES OF MECHANICAL SEAL						
VCEGG	V	C	E	G	G	-10 +110
Q ₁ Q ₁ EGG	Q ₁	Q ₁	E	G	G	-10 +110
VCVGG	V	C	V	G	G	-10 +110
Q ₁ Q ₁ VGG	Q ₁	Q ₁	V	G	G	-10 +110

cean-can_tipi-ten-mec-en_b_tc

GCA-GCA(N) SERIES HYDRAULIC PERFORMANCE TABLE AT 50 Hz, 2 POLES

PUMP TYPE	RATED POWER		Q = DELIVERY												
			l/min	0	30	40	50	60	70	80	100	120	150	180	210
			m ³ /h	0	1,8	2,4	3	3,6	4,2	4,8	6	7,2	9	10,8	12,6
		H = TOTAL HEAD METRES COLUMN OF WATER													
	kW	HP													
GCA(M) 70/33	0,75	1	42,9	38,8	36,9	34,6	31,7	28,2	23,9						
GCA(M) 70/34	0,9	1,2	48,8	45,1	43,2	40,7	37,7	34,0	29,5						
GCA(M) 70/45	1,1	1,5	56,2	52,0	49,8	47,1	43,9	39,9	35,3						
GCA(M) 120/33	1,1	1,5	44,3			39,1	37,8	36,4	34,8	31,4	27,6	21,0			
GCA(M) 120/35	1,5	2	54,0			49,4	48,1	46,6	44,9	41,2	36,8	29,3			
GCA(M) 120/55	2,2	3	63,8			59,6	58,2	56,6	54,8	50,6	45,7	37,1			
GCA(M) 200/33	1,85	2,5	43,2			41,8	41,2	40,6	39,9	38,3	36,4	33,2	29,5	25,5	
GCA(M) 200/35	2,2	3	53,5			52,4	51,9	51,4	50,7	49,2	47,5	44,3	40,6	36,5	
GCA 200/55	3	4	62,6			61,0	60,6	60,1	59,5	58,2	56,6	53,8	50,4	46,2	

gca-2p50-en_d_th

GCA-GCA(N) SERIES ELECTRICAL DATA AT 50 Hz, 2 POLES

PUMP TYPE	MOTOR TYPE	INPUT POWER*	INPUT CURRENT* 220-240 V	CAPACIT. μF / 450 V	PUMP TYPE	MOTOR TYPE	INPUT POWER*	INPUT CURRENT* 220-240 V	INPUT CURRENT* 380-415 V
		kW	A				kW	A	A
GCA70/33	SM71CA/1075	1,15	5,16	20	GCA70/33	SM80CA/307PE	1,06	3,24	1,87
GCA70/34	SM71CA/1095	1,39	6,22	25	GCA70/34	SM80CA/311PE	1,28	4,10	2,37
GCA70/45	SM80CA/1115	1,76	7,92	30	GCA70/45	SM80CA/311PE	1,63	4,90	2,83
GCA120/33	SM80CA/1115	1,67	7,53	30	GCA120/33	SM80CA/311PE	1,54	4,69	2,71
GCA120/35	SM80CA/1155	2,18	9,87	40	GCA120/35	SM80CA/315PE	2,01	6,11	3,53
GCA120/55	PLM90CA/1225	2,54	11,5	70	GCA120/55	PLM90CA/322	2,55	8,05	4,65
GCA200/33	PLM90CA/1225	2,29	10,4	70	GCA200/33	PLM90CA/322	2,26	7,47	4,31
GCA200/35	PLM90CA/1225	2,94	12,6	70	GCA200/35	PLM90CA/322	3,02	9,08	5,24
-	-	-	-	-	CA200/55	PLM90CA/330	3,51	10,7	6,18

*Maximum value in specified range.

gca-2p50-en_f_te

MOTORS FOR GCA-GCA(N) SERIES

Standard supplied IE2/IE3 three-phase surface motors $\geq 0,75$ kW are compliant with Regulation (EC) no. 640/2009 and IEC 60034-30.

Electrical performances according to EN 60034-1.

Insulation class 155 (F). IP55 protection. Condensate drain plugs on standard version.

Cooling by fan according to EN 60034-6.

Cable gland metric size according to EN 50262. Standard voltage:

- **Single-phase version:** 220-240 V 50 Hz (incorporated automatic-reset overload protection).
- **Three-phase version:** 220-240/380-415 V 50 Hz (overload protection to be provided by the user).

SINGLE-PHASE MOTORS AT 50 Hz, 2 POLES

P _N kW	MOTOR TYPE	IEC SIZE	Construction Design	INPUT CURRENT I _n (A)		CAPACITOR		DATA FOR 230 V 50 Hz VOLTAGE						
				220-240 V		μF	V	min ⁻¹	I _s / I _n	η %	cosφ	T _n Nm	T _s /T _n	T _m /T _n
0,75	SM71CA/1075	71	SPECIAL	4,90-4,85		20	450	2765	3,42	70,1	0,96	2,59	0,58	1,75
0,95	SM71CA/1095	71		6,25-5,89		25	450	2740	3,39	71,1	0,98	3,31	0,58	1,66
1,1	SM80CA/1115	80		6,88-6,65		30	450	2800	3,89	74,7	0,96	3,75	0,46	1,72
1,5	SM80CA/1155	80		9,21-8,58		40	450	2810	4,00	76,1	0,98	5,09	0,39	1,74
1,85	PLM80CA/1225	90		12,5-11,6		70	450	2825	4,47	82,4	0,97	7,43	0,53	1,87
2,2	PLM80CA/1225	90		12,5-11,6		70	450	2825	4,47	82,4	0,97	7,43	0,53	1,87

THREE-PHASE MOTORS AT 50 Hz, 2 POLES

ca-motm-2p50-en_a_te

P _N kW	Efficiency η _N %																		IE	Year of manufacture
	Δ 220 V Y 380 V			Δ 230 V Y 400 V			Δ 240 V Y 415 V			Δ 380 V Y 660 V			Δ 400 V Y 690 V			Δ 415 V				
	4/4	3/4	2/4	4/4	3/4	2/4	4/4	3/4	2/4	4/4	3/4	2/4	4/4	3/4	2/4	4/4	3/4	2/4		
0,75	82,5	83,1	81,3	82,8	82,7	80,1	82,6	82,0	78,9	82,5	82,0	78,9	82,5	82,0	78,9	82,5	82,0	78,9	3	By June 2011
0,9	84,0	84,7	83,4	84,4	84,5	82,5	84,3	84,0	81,4	84,0	84,0	81,4	84,0	84,0	81,4	84,0	84,0	81,4		
1,1	84,0	84,7	83,4	84,4	84,5	82,5	84,3	84,0	81,4	84,0	84,0	81,4	84,0	84,0	81,4	84,0	84,0	81,4		
1,5	85,6	86,5	85,8	85,9	86,4	84,9	86,0	86,0	84,0	85,6	86,0	84,0	85,6	86,0	84,0	85,6	86,0	84,0		
1,85	83,7	83,7	83,7	83,7	83,7	83,7	83,7	83,7	83,7	83,7	83,7	83,7	83,7	83,7	83,7	83,7	83,7	83,7		
2,2	83,7	83,7	83,7	83,7	83,7	83,7	83,7	83,7	83,7	83,7	83,7	83,7	83,7	83,7	83,7	83,7	83,7	83,7		
3	85,5	86,8	85,6	86,1	86,8	85,6	86,3	86,8	85,6	85,5	86,8	85,6	85,5	86,8	85,6	85,5	86,8	85,6	2	

P _N kW	Manufacturer		IEC SIZE	Construction Design	N. of Poles	f _N Hz	Data for 400 V / 50 Hz Voltage				
	XYLEM WATER SYSTEMS USA LLC 1 Goulds Drive - Auburn NY 13021 - U.S.A.						cosφ	I _s / I _N	T _N Nm	T _s /T _N	T _m /T _N
	Model										
0,75	SM80CA/307PE		80	SPECIAL	2	50	0,78	7,38	2,48	3,57	3,75
0,9	SM80CA/311PE		80				0,79	8,31	3,63	3,95	3,95
1,1	SM80CA/311PE		80				0,79	8,31	3,63	3,95	3,95
1,5	SM80CA/315PE		80				0,80	8,80	4,96	4,31	4,10
1,85	PLM90BG/322		90				0,80	8,63	7,25	3,74	3,71
2,2	PLM90BG/322		90				0,80	8,63	7,25	3,74	3,71
3	PLM90BG/330		90	0,82	8,39	9,96	3,50	3,32			

P _N kW	Voltage U _N V										n _N min ⁻¹	See note.	Operating conditions **		
	Δ			Y			Δ			Y			Altitude Above Sea Level (m)	T. amb min/max °C	ATEX
	220 V	230 V	240 V	380 V	400 V	415 V	380 V	400 V	415 V	660 V					
0,75	2,96	2,94	2,96	1,71	1,70	1,71	1,70	1,69	1,70	0,98	0,98	2875 ÷ 2895	≤ 1000	-15 / 40	No
0,9	4,19	4,14	4,16	2,42	2,39	2,40	2,41	2,38	2,38	1,39	1,37	2870 ÷ 2900			
1,1	4,19	4,14	4,16	2,42	2,39	2,40	2,41	2,38	2,38	1,39	1,37	2870 ÷ 2900			
1,5	5,56	5,49	5,51	3,21	3,17	3,18	3,21	3,18	3,19	1,85	1,84	2870 ÷ 2895			
1,85	8,05	8,04	8,09	4,65	4,64	4,67	4,62	4,61	4,63	2,67	2,66	2885 ÷ 2900			
2,2	8,05	8,04	8,09	4,65	4,64	4,67	4,62	4,61	4,63	2,67	2,66	2885 ÷ 2900			
3	10,8	10,6	10,6	6,23	6,14	6,12	6,18	6,10	6,06	3,57	3,52	2850 ÷ 2885			

Note: Observe the regulations and codes locally in force regarding sorted waste disposal.

gca-ie2-mott-2p50-en_c_te

** Operating conditions to be referred to motor only. About electric pump, refer to limits in user's manual.

AVAILABLE VOLTAGES MOTORS FOR GCA-GCA(N) SERIES

P _N kW	IEC SIZE	SINGLE-PHASE							
		50 Hz				60 Hz			
		1 x 220-240	1 x 100	1 x 110-120	1 x 220-230	1 x 100	1 x 110-115	1 x 120-127	1 x 200-210
0,75	71	s	o	o	s	o	o	o	o
0,95	71	s	o	o	s	o	o	o	o
1,1	80	s	-	o	s	-	o	-	o
1,5	80	s	-	-	s	-	o	-	o
2,2	90	s	-	-	s	-	-	-	-

s = Standard voltage o = Optional voltage

P _N kW	THREE-PHASE - 2 POLES																		
	50 Hz							60 Hz					50/60 Hz						
	3 x 220-230-240/380-400-415	3 x 380-400-415/660-690	3 x 200-208/346-360	3 x 255-265/440-460	3 x 290-300/500-525	3 x 440-460/-	3 x 500-525/-	3 x 220-230/380-400	3 x 255-265-277/440-460-480	3 x 380-400/660-690	3 x 440-460-480/-	3 x 110-115/190-200	3 x 200-208/346-360	3 x 330-346/575-600	3 x 575/-	3 x 230/400 50 Hz	3 x 265/460 60 Hz	3 x 400/690 50 Hz	3 x 460/- 60 Hz
0,75	s	o	o	o	o	o	o	s	o	o	o	o	o	o	o	o	o	o	o
0,95	s	o	o	o	o	o	o	s	o	o	o	o	o	o	o	o	o	o	o
1,1	s	o	o	o	o	o	o	s	o	o	o	o	o	o	o	o	o	o	o
1,5	s	o	o	o	o	o	o	s	o	o	o	o	o	o	o	o	o	o	o
2,2	s	o	o	o	o	o	o	s	o	o	o	o	o	o	o	o	o	o	o
3	s	o	o	o	o	o	o	s	o	o	o	o	o	o	o	o	o	o	o

- = Not available

ca-volt-low-a-en_a_te

**GCA-GCA(N) SERIES
 HYDRAULIC PERFORMANCE RANGE AT 50 Hz, 2 POLES**

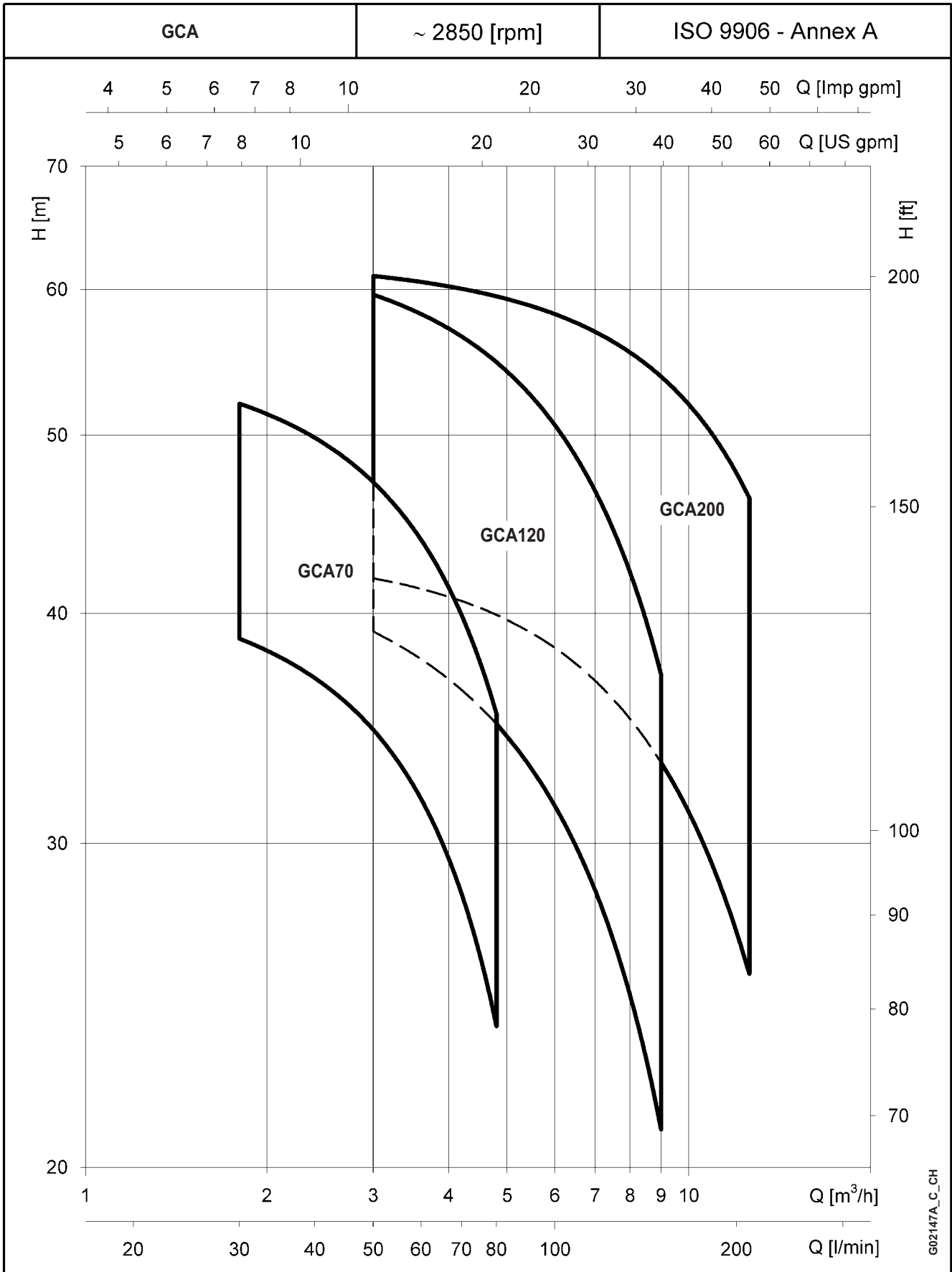

**GCA70 SERIES
 OPERATING CHARACTERISTICS AT 50 Hz, 2 POLES**

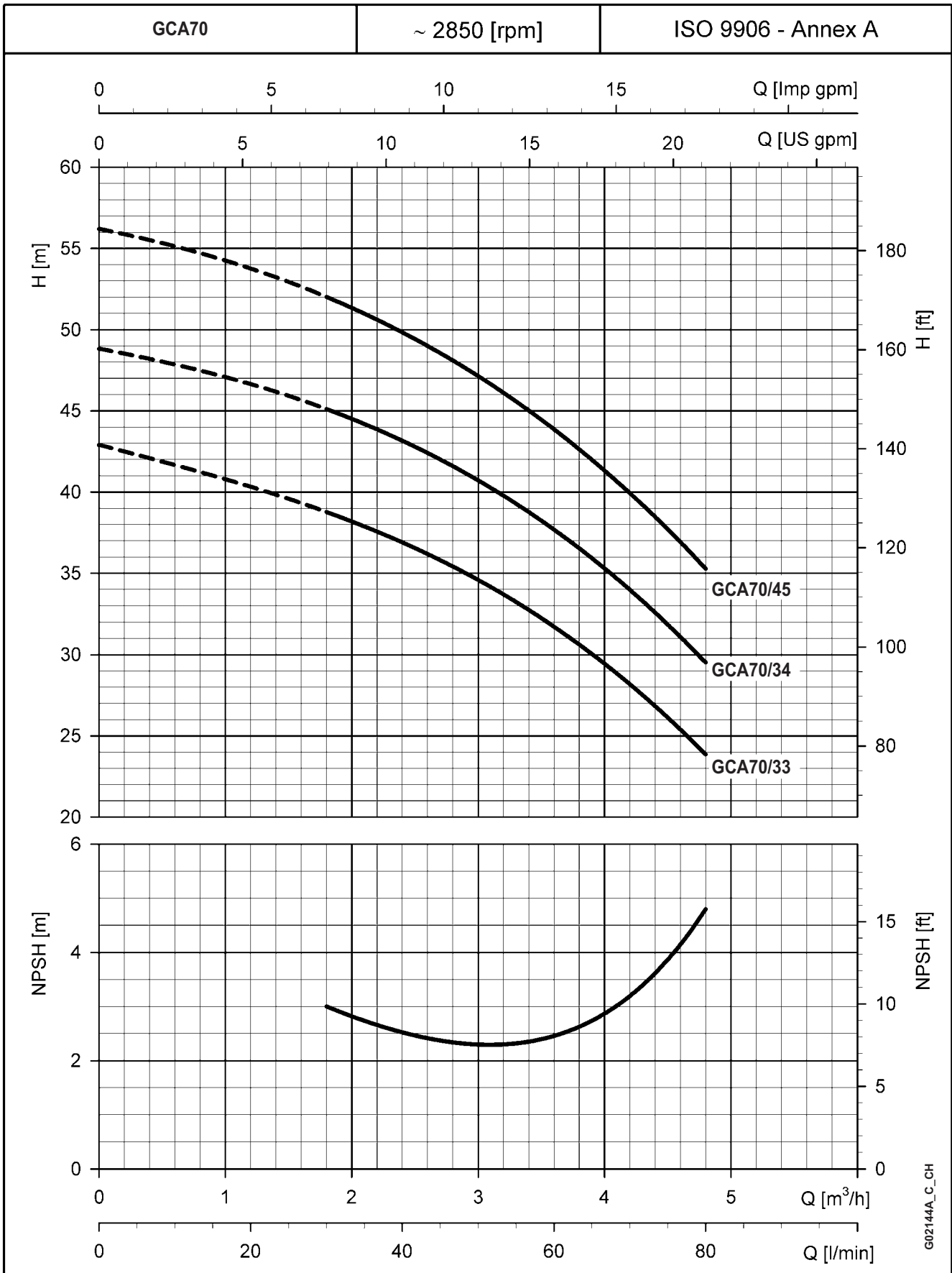

These performances are valid for liquids with density $\rho = 1.0 \text{ Kg/dm}^3$ and kinematic viscosity $\nu = 1 \text{ mm}^2/\text{sec}$.

**GCA120 SERIES
 OPERATING CHARACTERISTICS AT 50 Hz, 2 POLES**

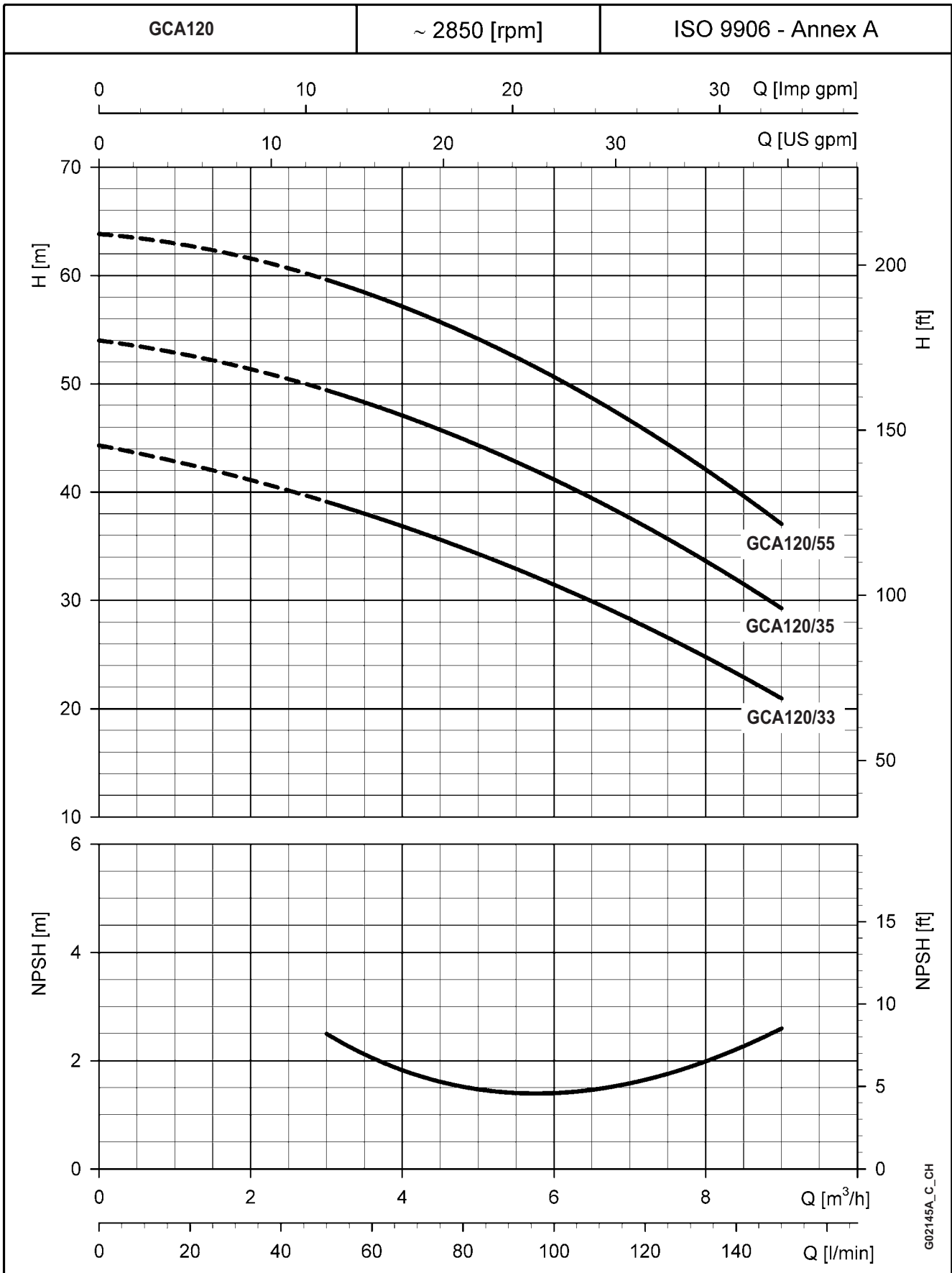

These performances are valid for liquids with density $\rho = 1.0 \text{ Kg/dm}^3$ and kinematic viscosity $\nu = 1 \text{ mm}^2/\text{sec}$.

**GCA200 SERIES
 OPERATING CHARACTERISTICS AT 50 Hz, 2 POLES**

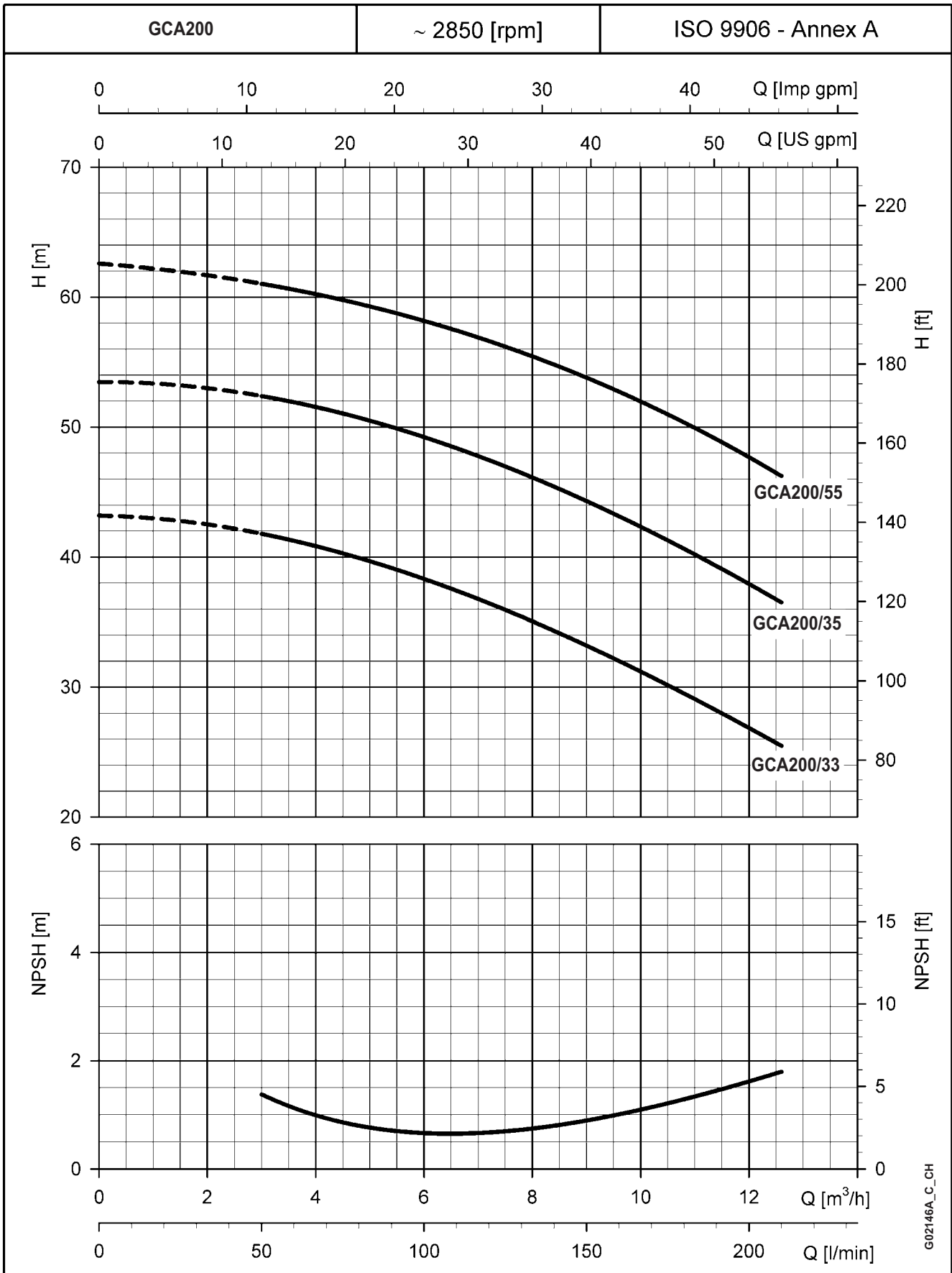

These performances are valid for liquids with density $\rho = 1.0 \text{ Kg/dm}^3$ and kinematic viscosity $\nu = 1 \text{ mm}^2/\text{sec}$.

**GCA-GCA(N) SERIES
DIMENSIONS AND WEIGHTS AT 50 Hz, 2 POLES**

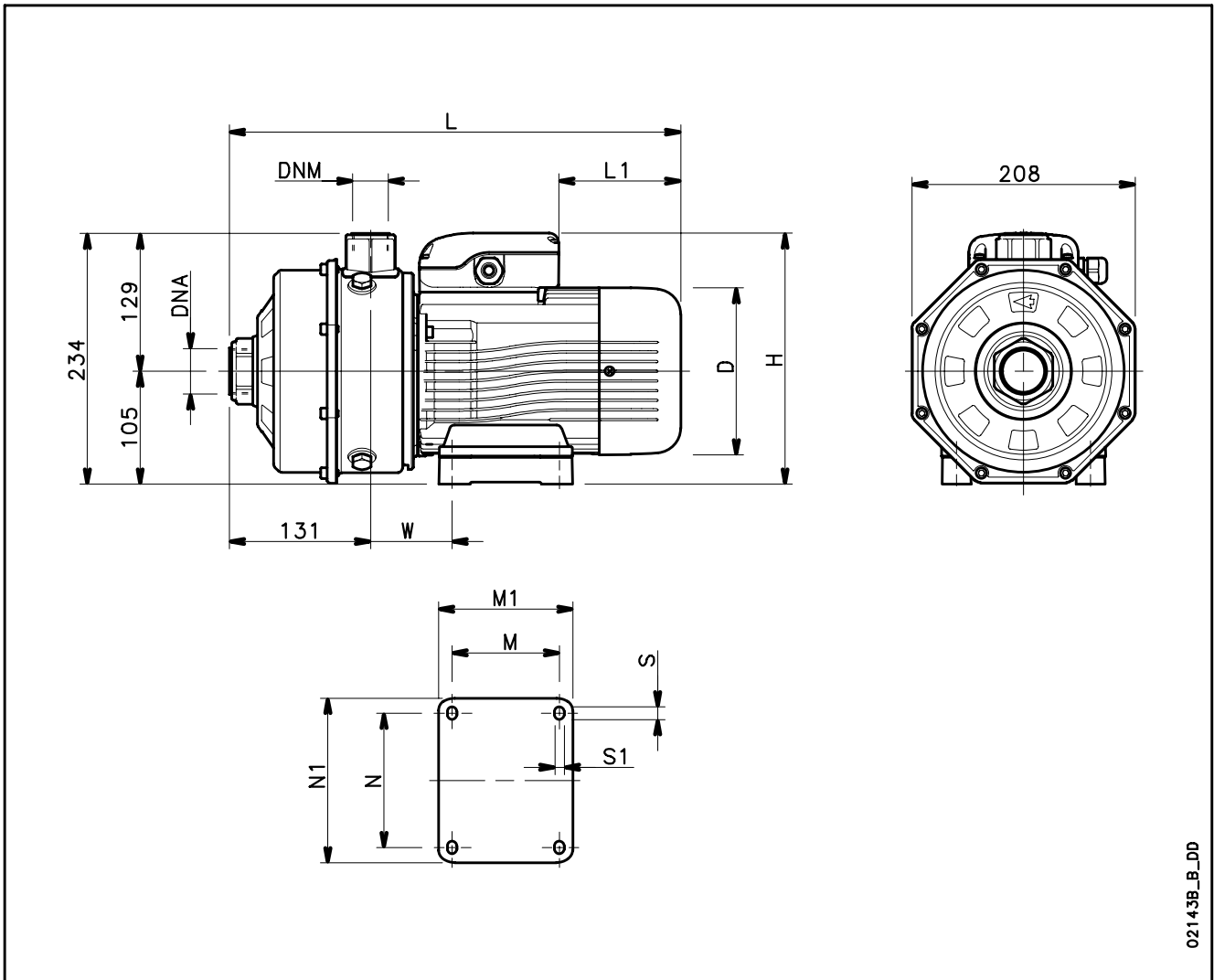

021*3B_B_DD

PUMP TYPE	DIMENSIONS (mm)											DNA	DNM	WEIGHT kg
	D	H	L	L1	M	M1	N	N1	S	S1	W			
GCAM 70/33/B	140	226	383	76	90	113	112	135	12	7	66	Rp 1/4	Rp 1	15
GCAM 70/34/B	140	235	383	31	90	113	112	135	12	7	66	Rp 1/4	Rp 1	15,8
GCAM 70/45/B	156	242	420	69	100	125	125	153	12	9	76	Rp 1/4	Rp 1	18,5
GCAM 120/33/B	156	242	420	69	100	125	125	153	12	9	76	Rp 1/4	Rp 1	18,4
GCAM 120/35/B	156	242	420	69	100	125	125	153	12	9	76	Rp 1/4	Rp 1	20,2
GCAM 120/55/P	174	256	454	84	125	155	140	170	13	10	98	Rp 1/4	Rp 1	27
GCAM 200/33/P	174	256	454	84	125	155	140	170	13	10	98	Rp 1/2	Rp 1	27
GCAM 200/35/P	174	256	454	84	125	155	140	170	13	10	98	Rp 1/2	Rp 1	27
GCA 70/33/D	155	234	420	114	100	125	125	153	12	9	76	Rp 1/4	Rp 1	16,7
GCA 70/34/D	155	234	420	114	100	125	125	153	12	9	76	Rp 1/4	Rp 1	17,4
GCA 70/45/D	155	234	420	114	100	125	125	153	12	9	76	Rp 1/4	Rp 1	18,7
GCA 120/33/D	155	234	420	114	100	125	125	153	12	9	76	Rp 1/4	Rp 1	18,7
GCA120/35/D	155	234	420	114	100	125	125	153	12	9	76	Rp 1/4	Rp 1	20,4
GCA 120/55/P	174	239	454	172	125	155	140	170	13	10	98	Rp 1/4	Rp 1	25
GCA 200/33/P	174	239	454	172	125	155	140	170	13	10	98	Rp 1/2	Rp 1	25
GCA 200/35/P	174	239	454	172	125	155	140	170	13	10	98	Rp 1/2	Rp 1	25
GCA 200/55/P	174	239	454	172	125	155	140	170	13	10	98	Rp 1/2	Rp 1	27

TECHNICAL APPENDIX

TYPICAL APPLICATIONS GCEA AND GCA SERIES ELECTRIC PUMPS

Water Purification:

Filtration
De-ionized water
Water treatment
Commercial and residential pools

Plastic Industry:

Temperature Regulators
Extrusion machines
Manufacture of polymers

Agricultural Residential Applications:

Irrigation
Greenhouses
Humidifiers
Water supply

Heating, Ventilating & Air

Conditioning:

Air scrubbers
Water re-circulation
Cooling towers
Cooling systems
Temperature control
Chillers
Induction heating
Heat exchangers
Water heating
Booster packages

General Industry:

Spray booths
Light chemical transfer
Booster systems

Medical:

Laser cooling
Massage
Medical chillers
Sanitary equipment

Waste Management:

Waste treatment
Pollution control

Machine Tool:

Degreasing
Parts washing
Chemical treatment
Heat treatment

Graphics:

Film washing
Cooling processes

Marine Sector:

Water on board ships

Computers:

Circuit board washing
Unit cooling

Laundry:

Commercial washers

Food and Drink:

Food processing
Bottle washing
Citrus processing
Dishwashing
Brewing
Sanitary ware

GCEA - GCA SERIES
 standard configuration: carbon/ceramic mechanical seal, NBR O-rings
 Compatibility chart for most commonly used liquids, for other compatible liquids refer to your standard contact

LIQUIDO LIQUID	FORMULA	CONCENTRAZIONE CONCENTRATION %	TEMPERATURA TEMPERATURE - MIN (°C) - MAX (°C)	PESO SPEC. DENSITY kg/dm ³	mechanical seal materials		TENUTA MECCANICA MECHANICAL SEAL			
					mechanical seal	o-ring	STD	number A	number P	Numero N
Acido Acetico Acetic acid configuration code	CH ₃ CO OH	80	-5 +70	1.05	Carb. di tung. - Carb. di sil. ...XPB	EPDM	3	3	1	3
Acido Citrico Citric acid configuration code	C ₆ H ₈ O ₇	5	-5 +70	1.54	carbon - ceramic ...XAA	FPM	2	1	2	2
Acido Fosforico Phosphoric acid configuration code	H ₃ PO ₄	20	-5 +30	1.33	Carb. di tung. - Carb. di sil. ...XPB	EPDM	3	2	1	1
Acqua Water configuration code	H ₂ O	100	-5 +85		carbon - ceramic standard product	NBR	1	1	1	1
Acqua Deionizzata Water deionized configuration code		100	-5 +85		carbon - ceramic ...XAA	FPM				
Acqua Demineralizzata Water demineralized configuration code		100	-5 +85		carbon - ceramic standard product	NBR				
Acqua di mare (4) Sea water (4) configuration code		/	-5 +25		not recommended					
Alcool Butilico Butyl alcohol configuration code	CH ₃ (CH ₂) ₇ CH ₂ OH	100	-5 +80	0.81	carbon - ceramic standard product	NBR	1	1	2	1
Alcool Etilico Ethyl alcohol (Ethanol) configuration code		100	-5 +40	0.81	carbon - ceramic standard product	NBR				
Alcool Metilico Methyl alcohol configuration code	CH ₃ OH	100	-5 +40	0.79	carbon - ceramic standard product	NBR	1	3	1	3
Cloroformio Chloroform configuration code	CHCl ₃	/	-5 +30	1.48	Carb. di tung. - Carb. di sil. ...XNA	FPM	3	2	3	1
Freon 112	CCl ₂ FCCl ₂ F	100	-5	1.57			2	2	3	1

WATER REQUIREMENTS IN CIVIL USERS

Determination of the water requirement depends on the type of users and contemporaneity factor. The calculation may be subject to regulations, standards or customs that may vary from country to country. The calculation method shown below is an example based on practical experience, designed to provide a reference value and not a substitute for detailed analytical calculation.

Water requirements in condominiums

The **consumption table** shows the maximum values for each delivery point, depending on the plumbing amenities.

MAXIMUM CONSUMPTION FOR EACH DELIVERY POINT

TYPE	CONSUMPTION (l/min)
Sink	9
Dishwasher	10
Washing machine	12
Shower	12
Bathtub	15
Washbasin	6
Bidet	6
Flush tank WC	6
Controlled flushing system WC	90

G-at-cm_a_th

The **sum of the water consumption values** of each delivery point determines the maximum theoretical requirement, which must be reduced according to the **contemporaneity coefficient**, because in actual fact the delivery points are never used all together.

$f = \frac{1}{\sqrt{(0,857 \times Nr \times Na)}}$	Coefficient for apartments with one bathroom and flush tank WC
$f = \frac{1}{\sqrt{(0,857 \times Nr \times Na)}}$	Coefficient for apartments with one bathroom and controlled flushing system WC
$f = \frac{1,03}{\sqrt{(0,545 \times Nr \times Na)}}$	Coefficient for apartments with two bathrooms and flush tank WC
$f = \frac{0,8}{\sqrt{(0,727 \times Nr \times Na)}}$	Coefficient for apartments with two bathrooms and controlled flushing system WC
f= coefficient; Nr= number of delivery points; Na= number of apartments	

The **table of water requirements in civil users** shows the maximum contemporaneity flow-rate values based on the **number of apartments** and the type of WC for apartments with one bathroom and two bathrooms. As regards apartments with one bathroom, 7 drawing points have been taken into consideration, while 11 points have been considered for apartments with two bathrooms. If the number of drawing points or apartments is different, use the formulas to **calculate** the requirement.

TABLE OF WATER REQUIREMENTS IN CIVIL USERS

NUMBER OF APARTMENTS	WITH FLUSH TANK WC		WITH CONTROLLED FLUSHING SYSTEM WC	
	1	2	1	2
	FLOW RATE (l/min)			
1	32	40	60	79
2	45	56	85	111
3	55	68	105	136
4	63	79	121	157
5	71	88	135	176
6	78	97	148	193
7	84	105	160	208
8	90	112	171	223
9	95	119	181	236
10	100	125	191	249
11	105	131	200	261
12	110	137	209	273
13	114	143	218	284
14	119	148	226	295
15	123	153	234	305
16	127	158	242	315
17	131	163	249	325
18	134	168	256	334
19	138	172	263	343
20	142	177	270	352
21	145	181	277	361
22	149	185	283	369
23	152	190	290	378
24	155	194	296	386
25	158	198	302	394
26	162	202	308	401
27	165	205	314	409
28	168	209	320	417
29	171	213	325	424
30	174	217	331	431
35	187	234	357	466
40	200	250	382	498
45	213	265	405	528
50	224	280	427	557
55	235	293	448	584
60	245	306	468	610
65	255	319	487	635
70	265	331	506	659
75	274	342	523	682
80	283	354	540	704
85	292	364	557	726
90	301	375	573	747
95	309	385	589	767
100	317	395	604	787
120	347	433	662	863
140	375	468	715	932
160	401	500	764	996
180	425	530	811	1056
200	448	559	854	1114

For seaside resorts, a flow rate increased by at least 20% must be considered.

G-at-fi_a_th

WATER REQUIREMENTS FOR COMMUNITY BUILDINGS

The requirements of buildings intended for specific uses, such as **offices, residential units, hotels, department stores, nursing homes** and so on, are different from those of condominiums, and both their global daily water consumption and the maximum contemporaneity flow rate are usually greater. The **diagram of water requirements for community buildings** shows the maximum contemporaneity flow rate of some types of communities, for guidance.

These requirements must be determined case by case with the utmost accuracy, using analytical calculation methods, according to particular needs and local provisions.

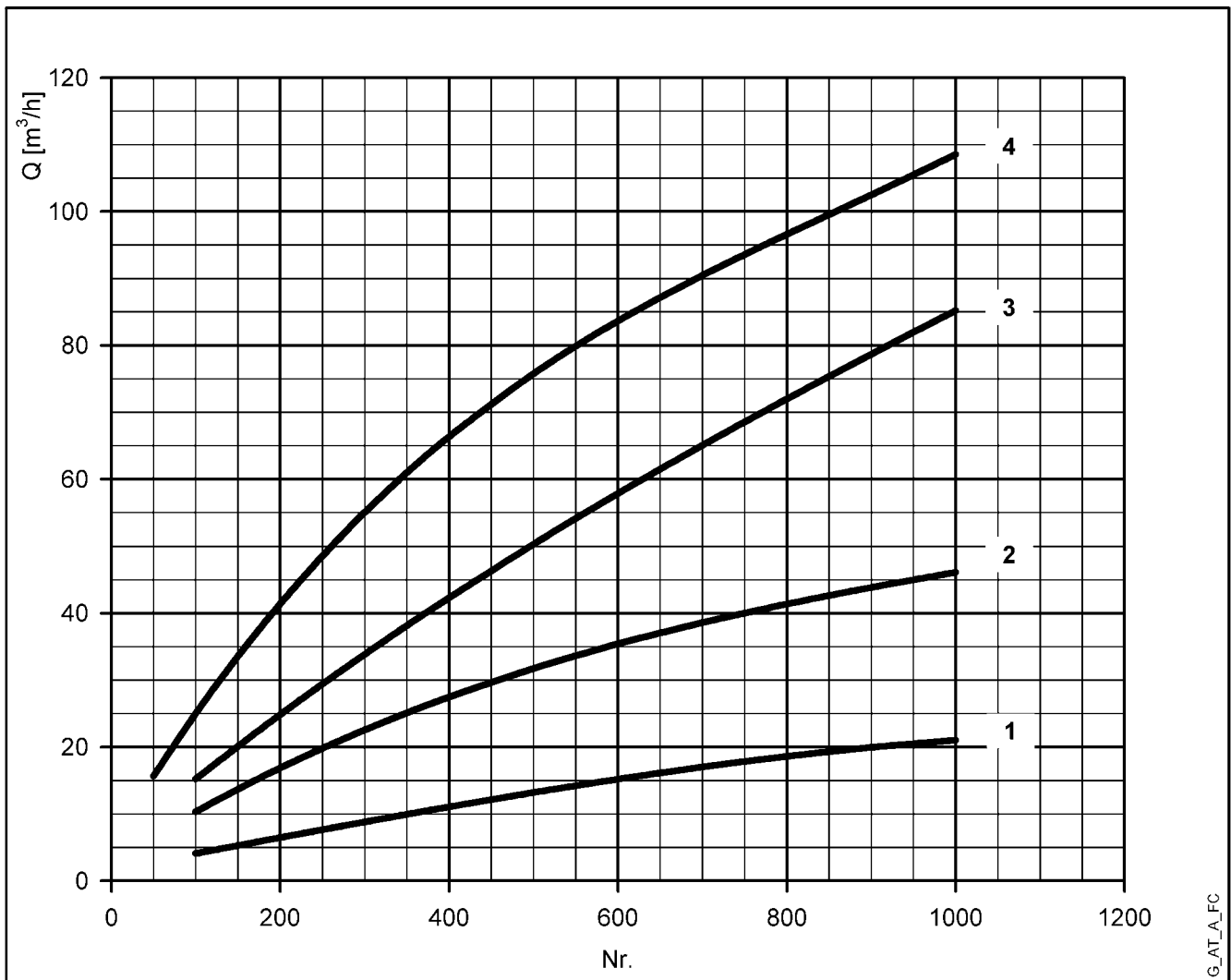

For seaside resorts, the flow rate must be increased by at least 20%.

- 1 = Offices (N. of people)
- 2 = Department stores (N. of people)
- 3 = Nursing homes (N. of beds)
- 4 = Hotels, residences (N. of beds)

NPSH

The minimum operating values that can be reached at the pump suction end are limited by the onset of cavitation.

Cavitation is the formation of vapour-filled cavities within liquids where the pressure is locally reduced to a critical value, or where the local pressure is equal to, or just below the vapour pressure of the liquid.

The vapour-filled cavities flow with the current and when they reach a higher pressure area the vapour contained in the cavities condenses. The cavities collide, generating pressure waves that are transmitted to the walls. These, being subjected to stress cycles, gradually become deformed and yield due to fatigue. This phenomenon, characterized by a metallic noise produced by the hammering on the pipe walls, is called incipient cavitation.

The damage caused by cavitation may be magnified by electrochemical corrosion and a local rise in temperature due to the plastic deformation of the walls. The materials that offer the highest resistance to heat and corrosion are alloy steels, especially austenitic steel. The conditions that trigger cavitation may be assessed by calculating the total net suction head, referred to in technical literature with the acronym NPSH (Net Positive Suction Head).

The NPSH represents the total energy (expressed in m.) of the liquid measured at suction under conditions of incipient cavitation, excluding the vapour pressure (expressed in m.) that the liquid has at the pump inlet.

To find the static height h_z at which to install the machine under safe conditions, the following formula must be verified:

$$h_p + h_z \geq (\text{NPSH}_r + 0.5) + h_f + h_{pv} \quad \textcircled{1}$$

where:

- h_p** is the absolute pressure applied to the free liquid surface in the suction tank, expressed in m. of liquid; h_p is the quotient between the barometric pressure and the specific weight of the liquid.
- h_z** is the suction lift between the pump axis and the free liquid surface in the suction tank, expressed in m.; h_z is negative when the liquid level is lower than the pump axis.
- h_f** is the flow resistance in the suction line and its accessories, such as: fittings, foot valve, gate valve, elbows, etc.
- h_{pv}** is the vapour pressure of the liquid at the operating temperature, expressed in m. of liquid. h_{pv} is the quotient between the Pv vapour pressure and the liquid's specific weight.
- 0,5** is the safety factor.

The maximum possible suction head for installation depends on the value of the atmospheric pressure (i.e. the elevation above sea level at which the pump is installed) and the temperature of the liquid.

To help the user, with reference to water temperature (4° C) and to the elevation above sea level, the following tables show the drop in hydraulic pressure head in relation to the elevation above sea level, and the suction loss in relation to temperature.

Water temperature (°C)	20	40	60	80	90	110	120
Suction loss (m)	0,2	0,7	2,0	5,0	7,4	15,4	21,5

Elevation above sea level (m)	500	1000	1500	2000	2500	3000
Suction loss (m)	0,55	1,1	1,65	2,2	2,75	3,3

Friction loss is shown in the tables at pages 40-41 of this catalogue. To reduce it to a minimum, especially in cases of high suction head (over 4-5 m.) or within the operating limits with high flow rates, we recommend using a suction line having a larger diameter than that of the pump's suction port. It is always a good idea to position the pump as close as possible to the liquid to be pumped.

Make the following calculation:

Liquid: water at ~15°C $\gamma = 1 \text{ kg/dm}^3$

Flow rate required: 30 m³/h

Head for required delivery: 43 m.

Suction lift: 3,5 m.

The selection is an GFHE 40-200/75 pump whose NPSH required value is, at 30 m³/h, di 2,5 m.

For water at 15 °C

$$h_p = P_a / \gamma = 10,33\text{m}, h_{pv} = P_v / \gamma = 0,174\text{m} (0,01701 \text{ bar})$$

The H_f flow resistance in the suction line with foot valves is ~ 1,2 m.

By substituting the parameters in formula $\textcircled{1}$ with the numeric values above, we have:

$$10,33 + (-3,5) \geq (2,5 + 0,5) + 1,2 + 0,17$$

from which we have: 6,8 > 4,4

The relation is therefore verified.

TECHNICAL APPENDIX VAPOUR PRESSURE PS VAPOUR PRESSURE AND ρ DENSITY OF WATER TABLE

t °C	T K	ps bar	ρ kg/dm ³	t °C	T K	ps bar	ρ kg/dm ³	t °C	T K	ps bar	ρ kg/dm ³
0	273,15	0,00611	0,9998	55	328,15	0,15741	0,9857	120	393,15	1,9854	0,9429
1	274,15	0,00657	0,9999	56	329,15	0,16511	0,9852	122	395,15	2,1145	0,9412
2	275,15	0,00706	0,9999	57	330,15	0,17313	0,9846	124	397,15	2,2504	0,9396
3	276,15	0,00758	0,9999	58	331,15	0,18147	0,9842	126	399,15	2,3933	0,9379
4	277,15	0,00813	1,0000	59	332,15	0,19016	0,9837	128	401,15	2,5435	0,9362
5	278,15	0,00872	1,0000	60	333,15	0,1992	0,9832	130	403,15	2,7013	0,9346
6	279,15	0,00935	1,0000	61	334,15	0,2086	0,9826	132	405,15	2,867	0,9328
7	280,15	0,01001	0,9999	62	335,15	0,2184	0,9821	134	407,15	3,041	0,9311
8	281,15	0,01072	0,9999	63	336,15	0,2286	0,9816	136	409,15	3,223	0,9294
9	282,15	0,01147	0,9998	64	337,15	0,2391	0,9811	138	411,15	3,414	0,9276
10	283,15	0,01227	0,9997	65	338,15	0,2501	0,9805	140	413,15	3,614	0,9258
11	284,15	0,01312	0,9997	66	339,15	0,2615	0,9799	145	418,15	4,155	0,9214
12	285,15	0,01401	0,9996	67	340,15	0,2733	0,9793	155	428,15	5,433	0,9121
13	286,15	0,01497	0,9994	68	341,15	0,2856	0,9788	160	433,15	6,181	0,9073
14	287,15	0,01597	0,9993	69	342,15	0,2984	0,9782	165	438,15	7,008	0,9024
15	288,15	0,01704	0,9992	70	343,15	0,3116	0,9777	170	443,15	7,920	0,8973
16	289,15	0,01817	0,9990	71	344,15	0,3253	0,9770	175	448,15	8,924	0,8921
17	290,15	0,01936	0,9988	72	345,15	0,3396	0,9765	180	453,15	10,027	0,8869
18	291,15	0,02062	0,9987	73	346,15	0,3543	0,9760	185	458,15	11,233	0,8815
19	292,15	0,02196	0,9985	74	347,15	0,3696	0,9753	190	463,15	12,551	0,8760
20	293,15	0,02337	0,9983	75	348,15	0,3855	0,9748	195	468,15	13,987	0,8704
21	294,15	0,24850	0,9981	76	349,15	0,4019	0,9741	200	473,15	15,550	0,8647
22	295,15	0,02642	0,9978	77	350,15	0,4189	0,9735	205	478,15	17,243	0,8588
23	296,15	0,02808	0,9976	78	351,15	0,4365	0,9729	210	483,15	19,077	0,8528
24	297,15	0,02982	0,9974	79	352,15	0,4547	0,9723	215	488,15	21,060	0,8467
25	298,15	0,03166	0,9971	80	353,15	0,4736	0,9716	220	493,15	23,198	0,8403
26	299,15	0,03360	0,9968	81	354,15	0,4931	0,9710	225	498,15	25,501	0,8339
27	300,15	0,03564	0,9966	82	355,15	0,5133	0,9704	230	503,15	27,976	0,8273
28	301,15	0,03778	0,9963	83	356,15	0,5342	0,9697	235	508,15	30,632	0,8205
29	302,15	0,04004	0,9960	84	357,15	0,5557	0,9691	240	513,15	33,478	0,8136
30	303,15	0,04241	0,9957	85	358,15	0,5780	0,9684	245	518,15	36,523	0,8065
31	304,15	0,04491	0,9954	86	359,15	0,6011	0,9678	250	523,15	39,776	0,7992
32	305,15	0,04753	0,9951	87	360,15	0,6249	0,9671	255	528,15	43,246	0,7916
33	306,15	0,05029	0,9947	88	361,15	0,6495	0,9665	260	533,15	46,943	0,7839
34	307,15	0,05318	0,9944	89	362,15	0,6749	0,9658	265	538,15	50,877	0,7759
35	308,15	0,05622	0,9940	90	363,15	0,7011	0,9652	270	543,15	55,058	0,7678
36	309,15	0,05940	0,9937	91	364,15	0,7281	0,9644	275	548,15	59,496	0,7593
37	310,15	0,06274	0,9933	92	365,15	0,7561	0,9638	280	553,15	64,202	0,7505
38	311,15	0,06624	0,9930	93	366,15	0,7849	0,9630	285	558,15	69,186	0,7415
39	312,15	0,06991	0,9927	94	367,15	0,8146	0,9624	290	563,15	74,461	0,7321
40	313,15	0,07375	0,9923	95	368,15	0,8453	0,9616	295	568,15	80,037	0,7223
41	314,15	0,07777	0,9919	96	369,15	0,8769	0,9610	300	573,15	85,927	0,7122
42	315,15	0,08198	0,9915	97	370,15	0,9094	0,9602	305	578,15	92,144	0,7017
43	316,15	0,09639	0,9911	98	371,15	0,9430	0,9596	310	583,15	98,70	0,6906
44	317,15	0,09100	0,9907	99	372,15	0,9776	0,9586	315	588,15	105,61	0,6791
45	318,15	0,09582	0,9902	100	373,15	1,0133	0,9581	320	593,15	112,89	0,6669
46	319,15	0,10086	0,9898	102	375,15	1,0878	0,9567	325	598,15	120,56	0,6541
47	320,15	0,10612	0,9894	104	377,15	1,1668	0,9552	330	603,15	128,63	0,6404
48	321,15	0,11162	0,9889	106	379,15	1,2504	0,9537	340	613,15	146,05	0,6102
49	322,15	0,11736	0,9884	108	381,15	1,3390	0,9522	350	623,15	165,35	0,5743
50	323,15	0,12335	0,9880	110	383,15	1,4327	0,9507	360	633,15	186,75	0,5275
51	324,15	0,12961	0,9876	112	385,15	1,5316	0,9491	370	643,15	210,54	0,4518
52	325,15	0,13613	0,9871	114	387,15	1,6362	0,9476	374,15	647,30	221,20	0,3154
53	326,15	0,14293	0,9862	116	389,15	1,7465	0,9460				
54	327,15	0,15002	0,9862	118	391,15	1,8628	0,9445				

G-at_nps_h_a_sc

TABLE OF FLOW RESISTANCE IN 100 m OF STRAIGHT CAST IRON PIPELINE (HAZEN-WILLIAMS FORMULA C=100)

FLOW RATE m ³ /h l/min		NOMINAL DIAMETER in mm and INCHES																												
		15 1/2"	20 3/4"	25 1"	32 1 1/4"	40 1 1/2"	50 2	65 2 1/2"	80 3"	100 4"	125 5"	150 6"	175 7"	200 8"	250 10"	300 12"	350 14"	400 16"												
0,6	10	v	0,94	0,53	0,34	0,21	0,13	The hr values must be multiplied by: 0.71 for galvanized or painted steel pipes 0.54 for stainless steel or copper pipes 0.47 for PVC or PE pipes																						
		hr	16	3,94	1,33	0,40	0,13																							
0,9	15	v	1,42	0,80	0,51	0,31	0,20																							
		hr	33,9	8,35	2,82	0,85	0,29																							
1,2	20	v	1,89	1,06	0,68	0,41	0,27												0,17											
		hr	57,7	14,21	4,79	1,44	0,49												0,16											
1,5	25	v	2,36	1,33	0,85	0,52	0,33												0,21											
		hr	87,2	21,5	7,24	2,18	0,73												0,25											
1,8	30	v	2,83	1,59	1,02	0,62	0,40												0,25											
		hr	122	30,1	10,1	3,05	1,03												0,35											
2,1	35	v	3,30	1,86	1,19	0,73	0,46												0,30											
		hr	162	40,0	13,5	4,06	1,37												0,46											
2,4	40	v		2,12	1,36	0,83	0,53												0,34	0,20										
		hr		51,2	17,3	5,19	1,75												0,59	0,16										
3	50	v		2,65	1,70	1,04	0,66												0,42	0,25										
		hr		77,4	26,1	7,85	2,65												0,89	0,25										
3,6	60	v		3,18	2,04	1,24	0,80												0,51	0,30										
		hr		108	36,6	11,0	3,71												1,25	0,35										
4,2	70	v		3,72	2,38	1,45	0,93												0,59	0,35										
		hr		144	48,7	14,6	4,93												1,66	0,46										
4,8	80	v		4,25	2,72	1,66	1,06	0,68	0,40																					
		hr		185	62,3	18,7	6,32	2,13	0,59																					
5,4	90	v			3,06	1,87	1,19	0,76	0,45	0,30																				
		hr			77,5	23,3	7,85	2,65	0,74	0,27																				
6	100	v			3,40	2,07	1,33	0,85	0,50	0,33																				
		hr			94,1	28,3	9,54	3,22	0,90	0,33																				
7,5	125	v			4,25	2,59	1,66	1,06	0,63	0,41																				
		hr			142	42,8	14,4	4,86	1,36	0,49																				
9	150	v				3,11	1,99	1,27	0,75	0,50	0,32																			
		hr				59,9	20,2	6,82	1,90	0,69	0,23																			
10,5	175	v				3,63	2,32	1,49	0,88	0,58	0,37																			
		hr				79,7	26,9	9,07	2,53	0,92	0,31																			
12	200	v				4,15	2,65	1,70	1,01	0,66	0,42																			
		hr				102	34,4	11,6	3,23	1,18	0,40																			
15	250	v				5,18	3,32	2,12	1,26	0,83	0,53	0,34																		
		hr				154	52,0	17,5	4,89	1,78	0,60	0,20																		
18	300	v					3,98	2,55	1,51	1,00	0,64	0,41																		
		hr					72,8	24,6	6,85	2,49	0,84	0,28																		
24	400	v					5,31	3,40	2,01	1,33	0,85	0,54	0,38																	
		hr					124	41,8	11,66	4,24	1,43	0,48	0,20																	
30	500	v					6,63	4,25	2,51	1,66	1,06	0,68	0,47																	
		hr					187	63,2	17,6	6,41	2,16	0,73	0,30																	
36	600	v					5,10	3,02	1,99	1,27	0,82	0,57	0,42																	
		hr					88,6	24,7	8,98	3,03	1,02	0,42	0,20																	
42	700	v					5,94	3,52	2,32	1,49	0,95	0,66	0,49																	
		hr					118	32,8	11,9	4,03	1,36	0,56	0,26																	
48	800	v					6,79	4,02	2,65	1,70	1,09	0,75	0,55																	
		hr					151	42,0	15,3	5,16	1,74	0,72	0,34																	
54	900	v					7,64	4,52	2,99	1,91	1,22	0,85	0,62																	
		hr					188	52,3	19,0	6,41	2,16	0,89	0,42																	
60	1000	v					5,03	3,32	2,12	1,36	0,94	0,69	0,53																	
		hr					63,5	23,1	7,79	2,63	1,08	0,51	0,27																	
75	1250	v					6,28	4,15	2,65	1,70	1,18	0,87	0,66																	
		hr					96,0	34,9	11,8	3,97	1,63	0,77	0,40																	
90	1500	v					7,54	4,98	3,18	2,04	1,42	1,04	0,80																	
		hr					134	48,9	16,5	5,57	2,29	1,08	0,56																	
105	1750	v					8,79	5,81	3,72	2,38	1,65	1,21	0,93																	
		hr					179	65,1	21,9	7,40	3,05	1,44	0,75																	
120	2000	v					6,63	4,25	2,72	1,89	1,39	1,06	0,68																	
		hr					83,3	28,1	9,48	3,90	1,84	0,96	0,32																	
150	2500	v					8,29	5,31	3,40	2,36	1,73	1,33	0,85																	
		hr					126	42,5	14,3	5,89	2,78	1,45	0,49																	
180	3000	v								6,37	4,08	2,83	2,08	1,59	1,02	0,71														
		hr								59,5	20,1	8,26	3,90	2,03	0,69	0,28														
210	3500	v								7,43	4,76	3,30	2,43	1,86	1,19	0,83														
		hr								79,1	26,7	11,0	5,18	2,71	0,91	0,38														
240	4000	v								8,49	5,44	3,77	2,77	2,12	1,36	0,94														
		hr								101	34,2	14,1	6,64	3,46	1,17	0,48														
300	5000	v									6,79	4,72	3,47	2,65	1,70	1,18														
		hr									51,6	21,2	10,0	5,23	1,77	0,73														
360	6000	v									8,15	5,66	4,16	3,18	2,04	1,42														
		hr									72,3	29,8	14,1	7,33	2,47	1,02														
420	7000	v										6,61	4,85	3,72	2,38	1,65	1,21													
		hr										39,6	18,7	9,75	3,29	1,35	0,64													
480	8000	v										7,55	5,55	4,25	2,72	1,89	1,39													
		hr										50,7	23,9	12,49	4,21	1,73	0,82													
540	9000	v										8,49	6,24	4,78	3,06	2,12	1,56	1,19												
		hr										63,0	29,8	15,5	5,24	2,16	1,02	0,53												
600	10000	v										6,93	5,31	4,00	2,66	1,73	1,33													
		hr										36,2	18,9	6,36	2,62	1,24	0,65													

G-at-pct_a_th

hr = flow resistance for 100m of straight pipeline (m)
V = water speed (m/s)

FLOW RESISTANCE

TABLE OF FLOW RESISTANCE IN BENDS, VALVES AND GATES

The flow resistance is calculated using the equivalent pipeline length method according to the table below:

ACCESSORY TYPE	DN											
	25	32	40	50	65	80	100	125	150	200	250	300
	Equivalent pipeline length (m)											
45° bend	0,2	0,2	0,4	0,4	0,6	0,6	0,9	1,1	1,5	1,9	2,4	2,8
90° bend	0,4	0,6	0,9	1,1	1,3	1,5	2,1	2,6	3,0	3,9	4,7	5,8
90° smooth bend	0,4	0,4	0,4	0,6	0,9	1,1	1,3	1,7	1,9	2,8	3,4	3,9
Union tee or cross	1,1	1,3	1,7	2,1	2,6	3,2	4,3	5,3	6,4	7,5	10,7	12,8
Gate	-	-	-	0,2	0,2	0,2	0,4	0,4	0,6	0,9	1,1	1,3
Non return valve	1,1	1,5	1,9	2,4	3,0	3,4	4,7	5,9	7,4	9,6	11,8	13,9

G-a-pcv_a_th

The table is valid for the Hazen Williams coefficient $C = 100$ (cast iron pipework). For steel pipework, multiply the values by 1.41. For stainless steel, copper and coated cast iron pipework, multiply the values by 1.85.

When the **equivalent pipeline length** has been determined, the flow resistance is obtained from the table of flow resistance.

The values given are guideline values which are bound to vary slightly according to the model, especially for gate valves and non-return valves, for which it is a good idea to check the values supplied by the manufacturers.

VOLUMETRIC CAPACITY

Litres per minute l/min	Cubic metres per hour m ³ /h	Cubic feet per hour ft ³ /h	Cubic feet per minute ft ³ /min	Imp. gal. per minute Imp. gal./min	US gal. per minute Us gal./min
1,000	0,0600	2,1189	0,0353	0,2200	0,2642
16,6667	1,000	35,3147	0,5886	3,6662	4,4029
0,4719	0,0283	1,000	0,0167	0,1038	0,1247
28,3168	1,6990	60,0000	1,000	6,2288	7,4805
4,5461	0,2728	9,6326	0,1605	1,000	1,2009
3,7854	0,2271	8,0208	0,1337	0,8327	1,000

PRESSURE AND HEAD

Newton per square metre N/m ²	kilo Pascal kPa	bar bar	Pound force per square inch psi	metre of water m H ₂ O	millimetre of mercury mm Hg
1,000	0,0010	1 x 10 ⁻⁵	1.45 x 10 ⁻⁴	1.02 x 10 ⁻⁴	0,0075
1000,0000	1,000	0,0100	0,1450	0,1020	7,5006
1 x 10 ⁵	100,0000	1,000	14,5038	10,1972	750,0638
6894,7570	6,8948	0,0689	1,000	0,7031	51,7151
9806,6500	9,8067	0,0981	1,4223	1,000	73,5561
133,3220	0,1333	0,0013	0,0193	0,0136	1,000

LENGTH

millimetre mm	centimetre cm	metre m	inch in	foot ft	yard yd
1,000	0,1000	0,0010	0,0394	0,0033	0,0011
10,0000	1,000	0,0100	0,3937	0,0328	0,0109
1000,0000	100,0000	1,000	39,3701	3,2808	1,0936
25,4000	2,5400	0,0254	1,000	0,0833	0,0278
304,8000	30,4800	0,3048	12,0000	1,000	0,3333
914,4000	91,4400	0,9144	36,0000	3,0000	1,000

VOLUME

cubic metre m ³	litre litro	millilitre ml	imp. Gallon imp. gal.	US gallon US gal.	cubic foot ft ³
1,000	1000,0000	1 x 10 ⁶	219,9694	264,1720	35,3147
0,0010	1,000	1000,0000	0,2200	0,2642	0,0353
1 x 10 ⁻⁶	0,0010	1,000	2.2 x 10 ⁻⁴	2.642 x 10 ⁻⁴	3.53 x 10 ⁻⁵
0,0045	4,5461	4546,0870	1,000	1,2009	0,1605
0,0038	3,7854	3785,4120	0,8327	1,000	0,1337
0,0283	28,3168	28316,8466	6,2288	7,4805	1,000

G-at_pp-en_a_sc

Xylem |'zīləm|

- 1) The tissue in plants that brings water upward from the roots;
- 2) a leading global water technology company.

We're 12,000 people unified in a common purpose: creating innovative solutions to meet our world's water needs. Developing new technologies that will improve the way water is used, conserved, and re-used in the future is central to our work. We move, treat, analyze, and return water to the environment, and we help people use water efficiently, in their homes, buildings, factories and farms. In more than 150 countries, we have strong, long-standing relationships with customers who know us for our powerful combination of leading product brands and applications expertise, backed by a legacy of innovation.

For more information on how Xylem can help you, go to xylem.com.

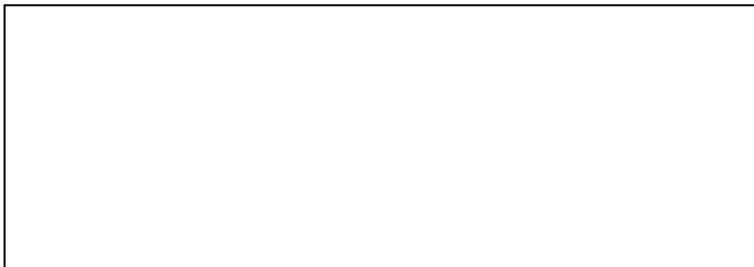

Headquarters
XYLEM WATER SYSTEMS USA LLC
1 Goulds Drive
Auburn, NY 13021 - U.S.A.
Phone: +1 (800) 453-6777
Fax: +1 (888) 322-5877

Goulds is a registered trademark of Goulds Pumps, Inc and is used under license.
© 2012 Xylem Inc.