

Centrifugal pumps

High flow

 Clean water

 Agricultural use

 Industrial use



PERFORMANCE RANGE

- Flow rate up to **2200 l/min** (132 m³/h)
- Head up to **24.5 m**

APPLICATION LIMITS

- Manometric suction lift up to **7 m**
- Liquid temperature between **-10 °C** and **+90 °C**
- Ambient temperature up to **+40 °C**
- Max. working pressure:
 - **6 bar** for HF 4
 - **10 bar** for HF 6-8-20-30
- Continuous service **S1**

CONSTRUCTION AND SAFETY STANDARDS

EN 60335-1
IEC 60335-1
CEI 61-150

EN 60034-1
IEC 60034-1
CEI 2-3



INSTALLATION AND USE

Suitable for use in civil and agricultural applications. The high efficiency and continuous duty capabilities makes these pumps ideal for use in activities such as flood and spray irrigation, drawing water from lakes, rivers and wells, or for any number of different industrial applications where the characteristics of high flow rates and mid to low head are required.

The pump should be installed in an enclosed environment or sheltered from inclement weather.

OPTIONS AVAILABLE ON REQUEST

- Pump body with NPT ANSI B 1.20.1 threaded ports
- Special mechanical seal
- Other voltages

GUARANTEE

2 years subject to terms and conditions

CERTIFICATIONS

Company with management system certified DNV
ISO 9001: QUALITY

CHARACTERISTIC CURVES AND PERFORMANCE DATA

60 Hz n = 3450 min⁻¹ HS = 0 m

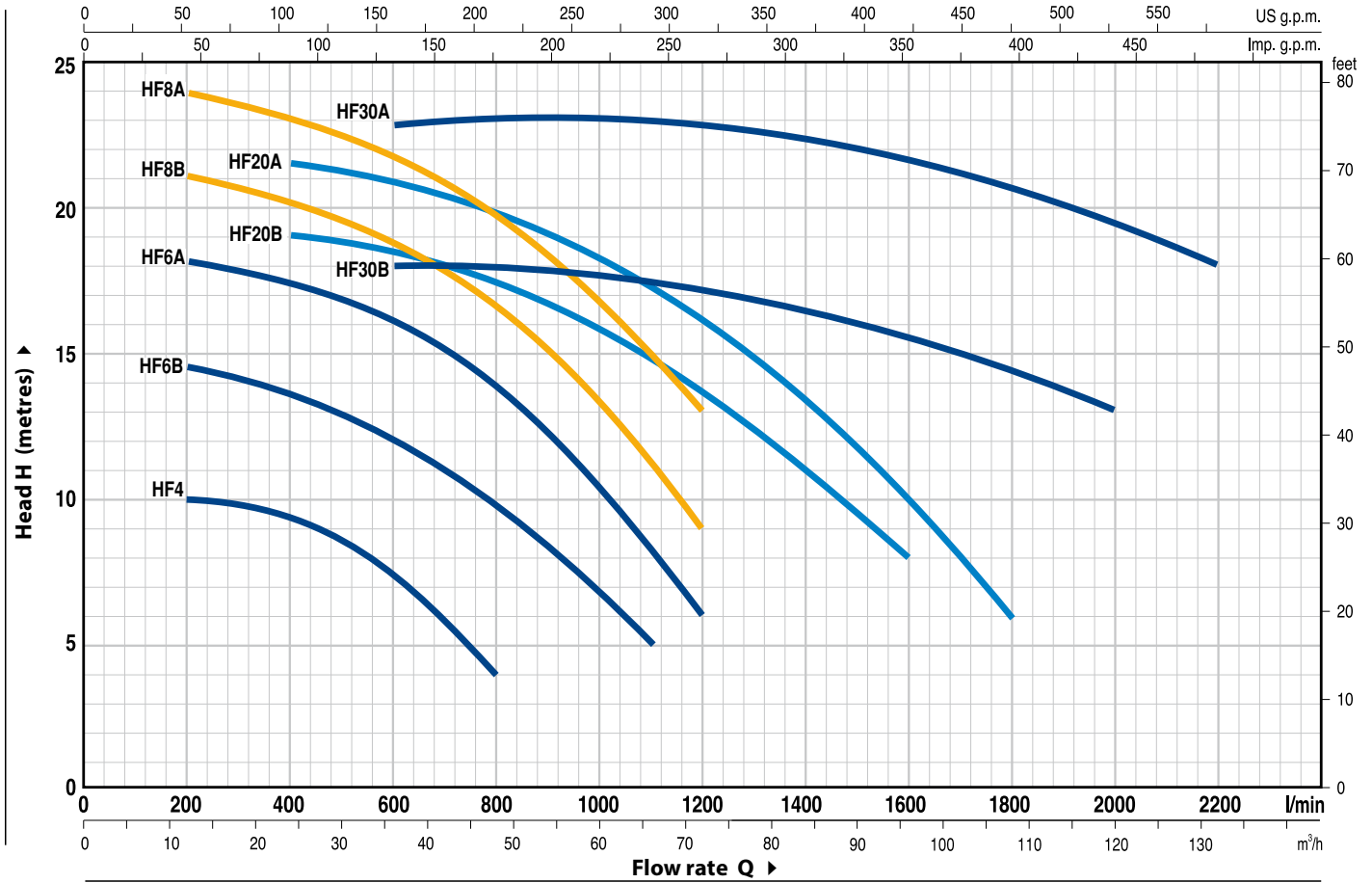

MODEL		POWER (P ₂)		▲	Q	m ³ /h																					
Single-ph.	Three-ph.	kW	HP			0	12	18	24	30	36	42	48	54	60	66	72	84	96	102	108	120	132				
					l/min	0	200	300	400	500	600	700	800	900	1000	1100	1200	1400	1600	1700	1800	2000	2200				
HFm 4	HF 4	0.75	1	IE3	H metres	10	10	9.8	9.4	8.6	7.3	5.8	4														
HFm 6B	HF 6B	1.5	2			14.7	14.5	14	13.5	12.8	12	11	9.7	8.2	6.7	5											
HFm 6A	HF 6A	2.2	3			18.5	18.1	17.8	17.2	16.8	16	15	13.8	12.2	10.5	8.3	6										
-	HF 8B	3	4			21.5	21	20.7	20	19.5	18.8	17.8	16.5	15	13.5	11.2	9										
-	HF 8A	4	5.5			24.5	24	23.5	23	22.5	21.8	20.8	19.5	18.3	16.8	15	13										
-	HF 20B	3	4			19	-	-	19	18.8	18.5	18	17.5	16.8	16	14.5	13.5	11	8								
-	HF 20A	4	5.5			21.5	-	-	21.5	21.3	21	20.5	19.8	19	18	17	16	13.3	10	8	6						
-	HF 30B	5.5	7.5			18	-	-	-	-	18	18	18	18	18	17.5	17	16.5	15.5	15	14.5	13					
-	HF 30A	7.5	10			23	-	-	-	-	23	23	23	23	23	22.5	22.5	22.5	22	21.5	21	19.5	18				

Q = Flow rate H = Total manometric head HS = Suction height

Tolerance of characteristic curves in compliance with EN ISO 9906 Grade 3B.

▲ Performance class of the three-phase motor (IEC 60034-30-1)

POS. COMPONENT CONSTRUCTION CHARACTERISTICS

1 PUMP BODY	Cast iron complete with threaded ports in compliance with ISO 228/1					
2 BODY BACKPLATE	Cast iron (stainless steel AISI 304 for HF 4)					
3 IMPELLER	Stainless steel AISI 304 for HF 4 Brass for HF 6, HF 8 Cast iron for HF 20, HF 30					
4 MOTOR SHAFT	Stainless steel EN 10088-3 - 1.4104					
5 MECHANICAL SEAL	<i>Pump</i>	<i>Seal</i>	<i>Shaft</i>	<i>Materials</i>		
	<i>Model</i>	<i>Model</i>	<i>Diameter</i>	<i>Stationary ring</i>	<i>Rotational ring</i>	<i>Elastomer</i>
	HF 4	AR-14	Ø 14 mm	Ceramic	Graphite	NBR
	HF 6	FN-18	Ø 18 mm	Graphite	Ceramic	NBR
	HF 8, HF 20	FN-20	Ø 20 mm	Graphite	Ceramic	NBR
HF 30	FN-24	Ø 24 mm	Graphite	Ceramic	NBR	
6 BEARINGS	<i>Pump</i>	<i>Model</i>				
	HF 4	6203 ZZ / 6203 ZZ				
	HF 6	6304 ZZ / 6204 ZZ				
	HF 8B, HF 20B	6206 ZZ - C3 / 6205 ZZ				
	HF 8A, HF 20A	6306 ZZ - C3 / 6206 ZZ - C3				
HF 30	6307 ZZ - C3 / 6206 ZZ - C3					
7 CAPACITOR	<i>Pump</i>	<i>Capacitance</i>				
	<i>Single-phase</i>	<i>(220 V)</i>	<i>(110 V or 127 V)</i>			
	HFm 4	20 µF - 450 VL	60 µF - 300 VL			
	HFm 6B	45 µF - 450 VL	80 µF - 250 VL			
HFm 6A	50 µF - 450 VL	-				
8 ELECTRIC MOTOR	HFm: single-phase 220 V - 60 Hz with thermal overload protector incorporated into the winding. HF: three-phase 220/380 V - 60 Hz or 220/440 V - 60 Hz. → The three-phase pump is fitted with a high performance motor in class IE3 (IEC 60034-30-1) - Insulation: class F - Protection: IP X4					

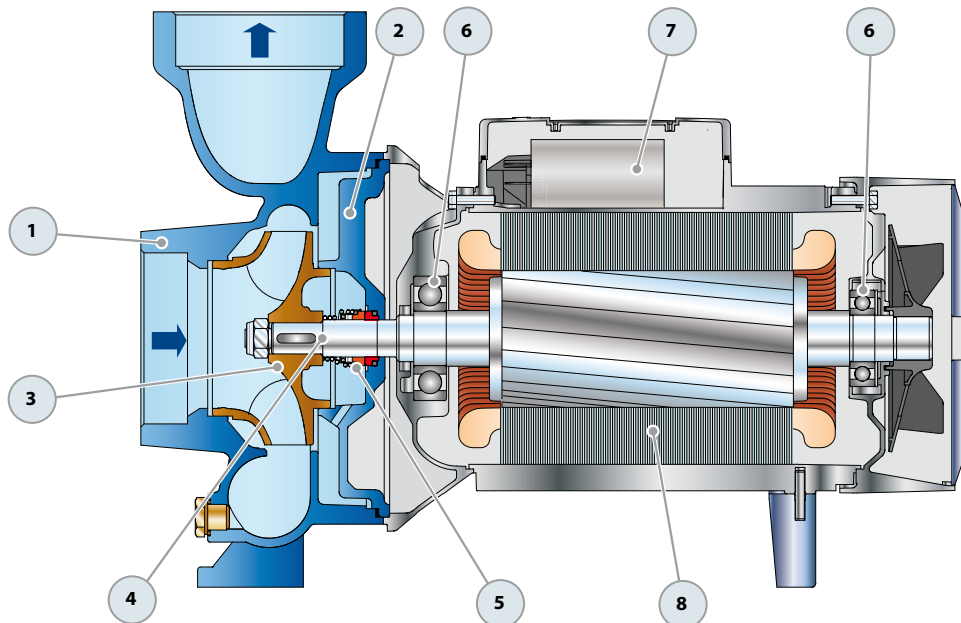

DIMENSIONS AND WEIGHT

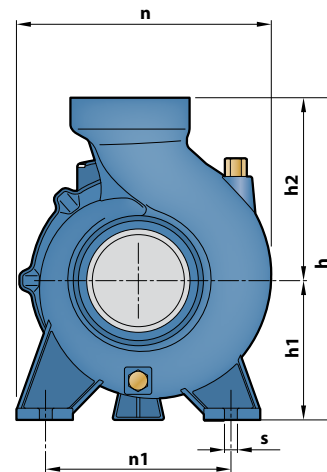
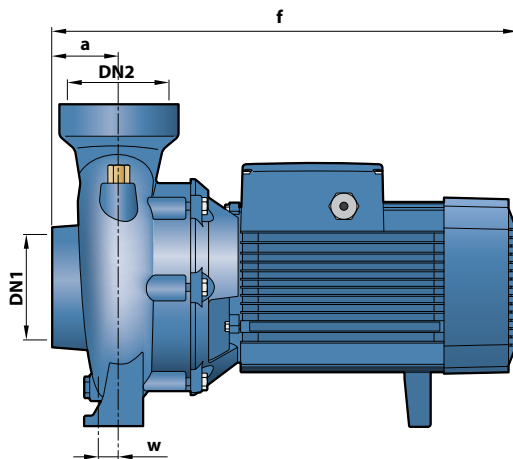

MODEL		PORTS		DIMENSIONS mm									kg	
Single-phase	Three-phase	DN1	DN2	a	f	h	h1	h2	n	n1	w	s	1~	3~
HFm 4	HF 4	2½"	2½"	47	317	240	97	143	198	155	-68	10	14.5	13.2
HFm 6B	HF 6B	3"	3"	68	411	312	120	192	240	190	6	12	26.5	25.5
	HF 6A				431								-	29.5
-	HF 8B	4"	4"	80	445	312	132	180	245	190	30	14	-	35.0
-	HF 8A				465								-	40.0
-	HF 20B				455								-	36.0
-	HF 20A				470								-	41.0
-	HF 30B	77	534	370	160	210	292	212	292	212	30	14	-	60.9
-	HF 30A												-	65.2

ABSORPTION

MODEL	VOLTAGE		
	220 V	110 V	127 V
Single-phase	220 V	110 V	127 V
HFm 4	6.6 A	13.2 A	12.6 A
HFm 6B	12.0 A	24.0 A	22.3 A
HFm 6A	14.5 A	-	-

MODEL	VOLTAGE			
	220 V	380 V	220 V	440 V
Three-phase	220 V	380 V	220 V	440 V
HF 4	5.0 A	2.9 A	4.2 A	2.4 A
HF 6B	8.6 A	5.0 A	7.6 A	4.2 A
HF 6A	10.7 A	6.2 A	9.0 A	4.8 A
HF 8B	12.0 A	7.0 A	13.0 A	7.0 A
HF 8A	18.2 A	10.5 A	18.5 A	12.0 A
HF 20B-N	12.0 A	7.0 A	13.0 A	7.0 A
HF 20A-N	18.2 A	10.5 A	17.8 A	11.0 A
HF 30B	22.5 A	13.0 A	20.1 A	11.8 A
HF 30A	28.8 A	16.6 A	28.0 A	16.7 A